



Operating Instructions

Filling Panels 1DB / 2DB





TABLE OF CONTENTS

General Information and Technical Data

General Information / Description of Warning Symbols	3
Scope of Delivery	4
Technical Data	5
Unit Assembly.....	6
Flow Chart - Filling Panel with one Pressure Range.....	7
Flow Chart - Filling Panel with two Pressure Ranges	8

Safety Precautions

Intended Use / Operators	10
General Safety Precautions	11
Unit customised safety notices	12
Maintenance instructions	13
Transportation instructions / Safety regulations.....	14

Installation

Mechanical Installation/Electrical Installation	16
---	----

Operation

Filling Panel with one Pressure Range / Filling Panel with two Pressure Ranges	18
Filling procedure	19

Maintenance and Service

Service, Repair and Maintenance	21
Maintenance Overview	22
Overhaul Instructions for Toggle Filling Valve	23 - 34
Maintenance records	36 - 37

Options

Storage control.....	39 - 41
Throttle valve.....	42
Inlet pressure reduction	43
Hour counter / Emergency stop switch	44
Anti-whip connections / 90° elbows for filling hoses.....	45

Spare Parts Lists / Detailed Views



GENERAL INFORMATION

General Information

We strongly recommend reading this manual thoroughly prior to operation and follow all the safety precautions precisely. Damage resulting from any deviation from these instructions is excluded from warranty and liability for this product. Carry out other commissioning steps only if you have fully understood the following contents.

Before commissioning and using the unit, carry out all the essential preliminary work and measures concerning legal regulations and safety. These are described on the following pages of this operation manual.

Description of marks and warning signs

The following warning signs are used in this document to identify the corresponding warning notes which require particular attention by the user. The warning signs are defined as follows:



Caution

Indicates an imminently hazardous situation which, if not avoided, could result in serious injury, physical injury or death.



Warning

Indicates a potentially hazardous situation which, if not avoided, could result in physical injury or damage to the product or environment.



Note

Indicates additional information on how to use the unit.



DESCRIPTION

Scope of Delivery

The wide range of L&W filling panels has established itself as an industry benchmark for optimum design with an extensive list of features. The modular design guarantees that filling stations can be extended to adapt to your future requirements. The panels are available with either 200, 232 or 300 bar filling pressure (3000/4500 psi) or as dual pressure filling panels for simultaneous filling without the need to select the pressure. The self venting lever operated filling valves are available with either filling hoses and connections or direct filling connections for BA cylinders. We have a wide range of filling connections available.

Specifications

- Steel frame, powder coated
- Steel plate housing powder coated
- 8 mm bulkhead fitting for air inlet (inter-changeable left/right)
- Ready for connection, piped with 8 mm stainless steel piping
- Start/Stop remote control with running control lamp (available for various compressor controls)
- Large Ø 100 mm pressure gauge for each filling pressure
- Self-venting lever filling valves (venting within the housing for noise reduction).
- Valves can be equipped with extra silencers for further noise reduction.
- Filling hoses or direct BA connections according to your specifications
- Large Ø 100 mm pressure gauge(s)
- Self-venting lever filling valves
- Panels for dual pressure equipped

Filling panels with filling hoses

- 1000 mm HP hoses with stainless steel fittings (longer hoses available)
- Filling connections anti-whip option recommended for DIN or NF connections

Filling panels with direct BA connections

- Direct BA connections for flanging the cylinders on to the panel
- Filling connections anti-whip option recommended for DIN or NF connections
- Dust caps and holders for DIN connections

Options available

- L&W anti-whip safety connections for DIN/NF connections
- Silencers for further reducing venting noise
- Storage inlet/outlet with hand wheel valve and pressure gauge
- Pressure reducer and safety valve in the inlet for 300 bar storage and only 200 bar filling
- 8 mm bulkhead outlet for additional filling panels (modular system)



DESCRIPTION

Technical Data

Technical Data	
Max. Pressure [bar]:	350
Medium:	Compressed Air / Breathing Air
Operating temperature [°C]:	+5 < +45
Noise level (measured at 1 m) [dB(A)]:	93

Dimensions and weights

Number of connections	Dimensions L x W x H [cm]		Weight [kg]	
	1 DB	2 DB	1 DB	2 DB
1-point	21 x 23 x 33	-	6.5	-
2-point	39 x 23 x 33	58 x 23 x 33	9	13
3-point	58 x 23 x 33	82 x 23 x 33	12	16
4-point	82 x 23 x 33	82 x 23 x 33	15	18
6-point	118 x 23 x 33	118 x 23 x 33	20	23
8-point	156 x 23 x 33	156 x 23 x 33	25	28
9-point	176 x 23 x 33	176 x 23 x 33	28	31
10-point	195 x 23 x 33	195 x 23 x 33	31	34

DESCRIPTION

Unit Assembly

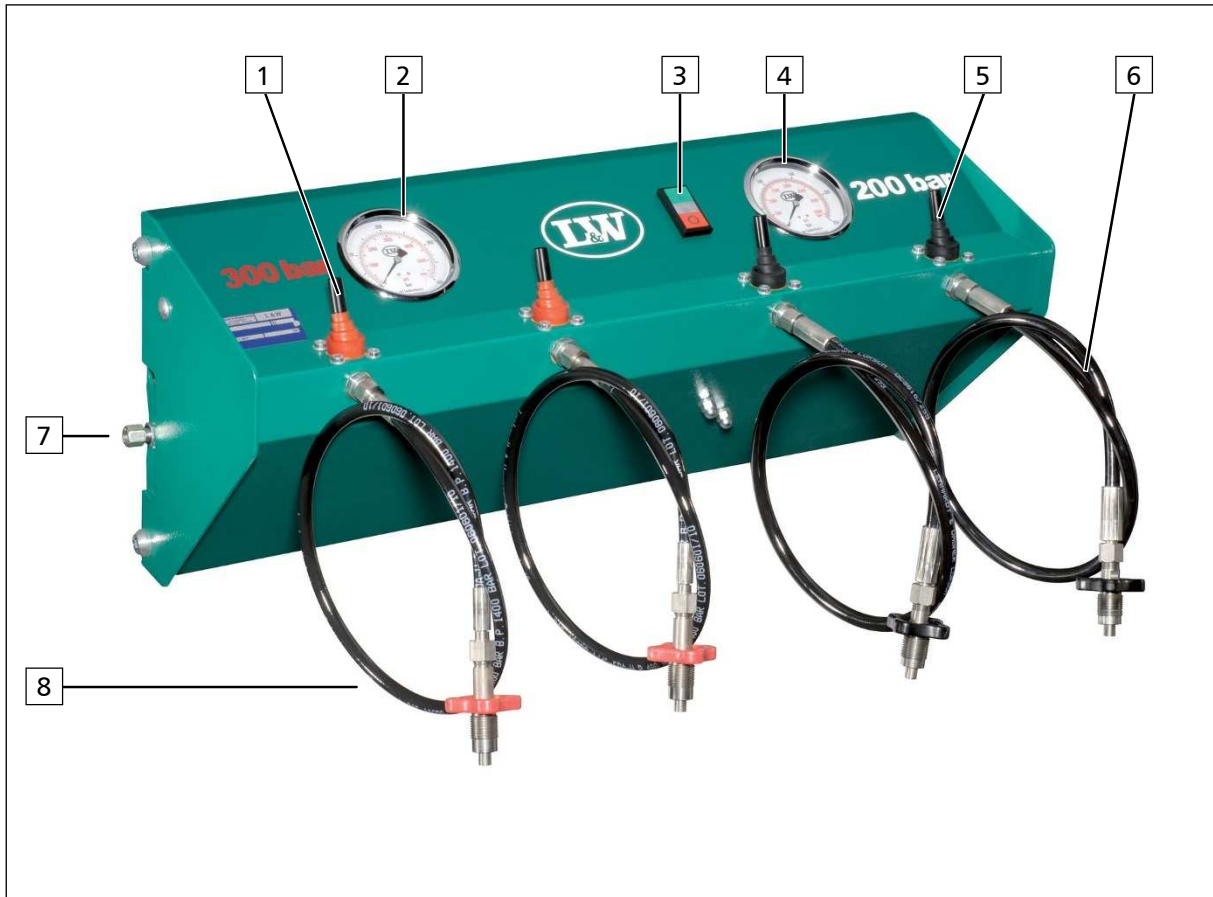

4 point panel - 2 x 200 bar, 2 x 300 bar with hoses and DIN anti-whip connections

No.	Designation
1	Lever Filling Valves 300 bar (red)
2	Pressure Gauge First Pressure Range (300 bar)
3	Start/Stop Button with Operating Lamp
4	Pressure Gauge Second Pressure Range (200 bar)
5	Lever Filling Valves 200 bar (black)
6	Filling Hose with DIN Charging Point (black / 200 bar)
7	High-pressure Inlet (8 mm)
8	Filling Hose with DIN Charging Point (red / 300 bar)

DESCRIPTION

Flow Chart - Filling Panel with One Pressure Range

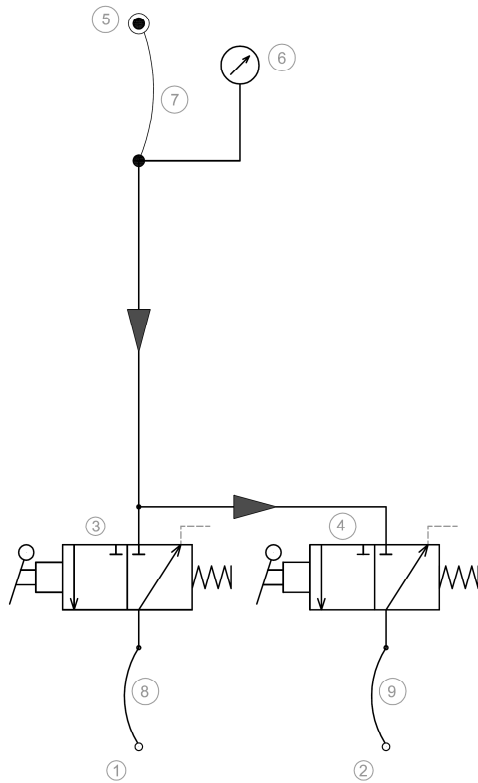

Filling Panel 2x 200 bar or 2x 300 bar LENHARDT & WAGNER GMBH

DATE: 18.07.2014

FLOW DIAGRAM

- 1 Tank Connector 200 or 300 bar, G5/8" DIN 477
- 2 Tank Connector 200 or 300 bar, G5/8" DIN 477
- 3 Lever Filling Valve
- 4 Lever Filling Valve
- 5 Inlet Connector 8L (M14 x 1.5mm)
- 6 Pressure Gauge (Ø100 mm, 0-250 bar or 0-400 bar)
- 7 HP-Hose
- 8 HP-Filling Hose
- 9 HP-Filling Hose

DESCRIPTION

Flow Chart - Filling Panel with Two Pressure Ranges

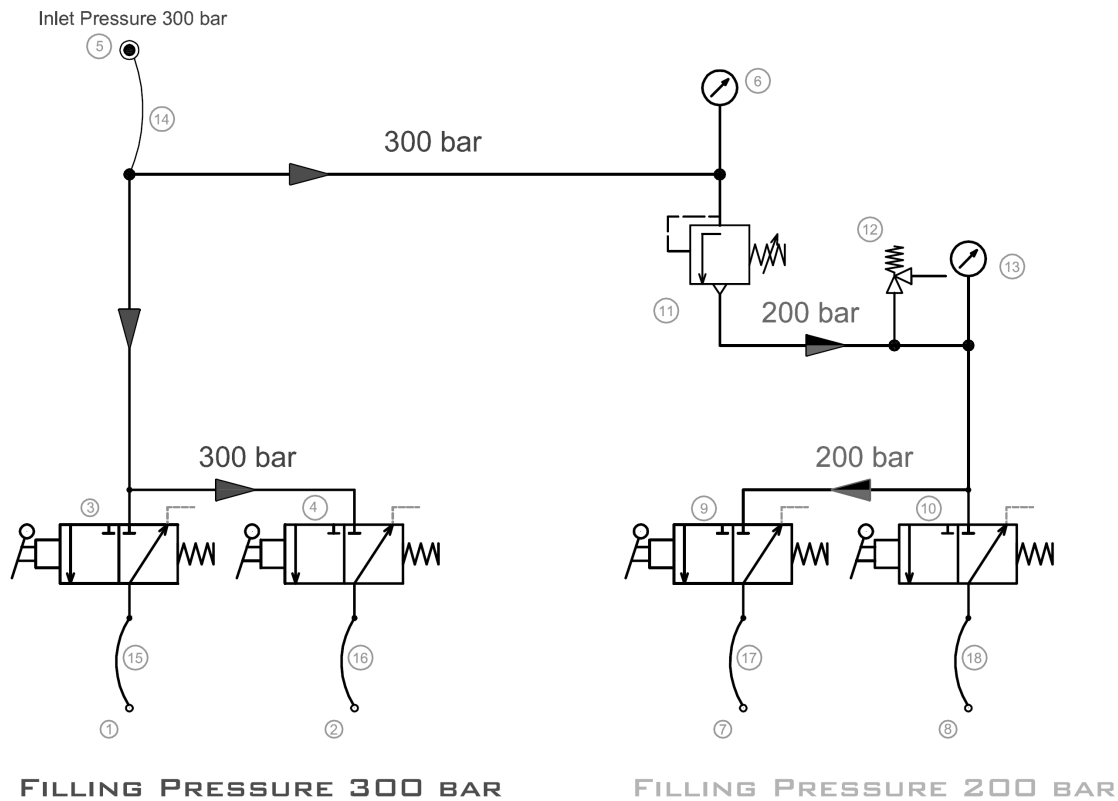

FLOW DIAGRAM

- 1 Tank Connector 300 bar, G5/8" DIN 477
- 2 Tank Connector 300 bar, G5/8" DIN 477
- 3 Lever Filling Valve
- 4 Lever Filling Valve
- 5 Inlet Connector 8L (M14 x 1.5mm)
- 6 Pressure Gauge 300 bar (0-400 bar, Ø100 mm)
- 7 Tank Connector 200 bar, G5/8" DIN 477
- 8 Tank Connector 200 bar, G5/8" DIN 477
- 9 Lever Filling Valve
- 10 Lever Filling Valve
- 11 Pressure Reducer (Set Pressure: 220 bar)
- 12 Safety Valve (Relief Pressure: 225 bar)
- 13 Pressure Gauge 200 bar (0-250 bar, Ø100 mm)
- 14 HP-Hose
- 15 HP-Filling Hose
- 16 HP-Filling Hose
- 17 HP-Filling Hose
- 18 HP-Filling Hose

Filling Panel 2x 200 bar & 2x 300 bar
 LENHARDT & WAGNER GMBH

DATE: 18.07.2014



SAFETY PRECAUTIONS



SAFETY PRECAUTIONS

Intended Use

Only use the unit in perfect condition for its intended purpose, safety and intended use and observe the operating instructions! In particular disorders that may affect safety have to be eliminated immediately!

Use the unit exclusively for the determined medium (see "Technical Data"). Any other use that is not specified is not authorized. The manufacturer/supplier shall not be liable for any damages resulting from such use. Such risk lies entirely with the user. Authorization for use is also under the condition that the instruction manual is complied with and inspection and maintenance requirements are enforced.

No change and modification to the unit can be made without the written agreement of the manufacturer. The manufacturer is not liable for damage to persons or property resulting from unauthorized modifications.

Operators

Target groups in these instructions;

Operators

Operators are persons who are authorized and briefed for the use of the compressor.

Qualified personnel

Qualified personnel are persons who are entitled to repair, service, modify and maintain the system.



Warning

Only trained personnel are permitted to work on the unit!



Warning

Work on the electrical equipment on / with the machine / unit may only be carried out by qualified electricians.



SAFETY PRECAUTIONS

General Safety Precautions

- Read the Operating Instructions of this product carefully prior to use.
- Strictly follow the instructions. The user must fully understand and strictly observe the instructions. Use the product only for the purposes specified in the intended use section of this document.
- Do not dispose the operating instructions. Ensure that they are retained and appropriately used by the product user.
- Only trained and competent personnel are permitted to use this product.
- Comply with all local and national rules and regulations associated with this product.
- Only trained and competent personnel are permitted to inspect, repair and service the product.
- Only authentic L&W parts and accessories may be used for maintenance work. Otherwise, the proper functioning of the product may be impaired.
- Do not use faulty or incomplete products. Do not modify the product.
- Inform L&W in the event of any product or component fault or failure.
- The quality of the air supply must meet EN 12021 specifications for breathing air.
- Do not use the product in areas prone to explosion or in the presence of flammable gases. The product is not designed for these applications. An explosion might be the result if certain conditions apply.



SAFETY PRECAUTIONS

Unit customised safety notices

Organisational measures

- In addition to the instruction manual, observe and comply with universally valid legal and other obligatory regulations regarding accident prevention and environment protection.
- In addition to the instruction manual, provide supplementary instructions for supervision and monitoring duties taking into consideration exceptional factors e.g. with regard to organisation of work, production, personnel employed.
- Supervise personnel's work in accordance with the instruction manual, taking into account safety and danger factors.
- Observe all safety and danger notices on the compressor and check readability and completeness.

Safety instructions operation

- Take measures to ensure that the machine is only taken into operation under safe and functional conditions. Only operate the compressor if all protective and safety equipment, e.g. detachable protective equipment, are provided and in good working order.
- Check the compressor at least once per day for obvious damage and defects. Inform the responsible department / person immediately if anything is not as it should be (including operation performance). Shut down the machine immediately if necessary and lock it.
- In case of malfunction, stop the compressor immediately and lock it. Repair malfunctions immediately.
- If there is a failure in the electric energy supply, shut the machine / unit down immediately.
- Ensure safe and environmentally friendly disposal of consumables and old parts.
- The stipulated hearing protectors must be worn.
- Soundproofing equipment on the compressor has to be activated in safety function during operation.
- When handling with fats, oils and other chemical agents, observe the note for the product-related safety.



SAFETY PRECAUTIONS

Maintenance instructions

- Hoses have to be checked by the operator (pressure and visual inspection) at reasonable intervals, even if no safety-related defects have been detected.
- Immediately repair any damage. Escaping compressed air can cause injury.
- Depressurise system and pressure lines before beginning repair work.
- Pressurised air lines must be laid and mounted by qualified personnel. Connections must not be mixed up. Fittings, length and quality of the piping must correspond to requirements.
- Adjustment, maintenance and inspection activities and keep appointments, including information on replacement parts / equipment, prescribed in the operating instructions have to be respected.
- The machine and especially the connections and fittings should be cleaned from oil, fuel and maintenance products at the beginning of the maintenance / repair. Do not use aggressive cleaning agents. Use fibre-free cleaning cloths.
- After cleaning, examine all pipes for leaks, loose connections, chafing and damage. Immediately eliminate any faults.
- Always retighten any screw connections loosened for maintenance or repair work.
- If it is necessary to remove safety devices for maintenance and repair work, these must be replaced and checked immediately after completion of the maintenance or repair work.
- Only personnel with particular knowledge and experience with pneumatics may carry out work on pneumatic equipment.
- Only personnel with particular knowledge and experience in gas equipment may carry out work on gas equipment.



SAFETY PRECAUTIONS

Transportation instructions

- Parts which need to be dismantled for transport purposes must be carefully replaced and secured before taking into operation.
- The transport may only be carried out by trained personnel.
- For transportation, only use lifting devices and equipment with sufficient lifting power.
- Do not stand or work under suspended loads.
- Also separate from minor relocation machinery / system of any external energy supply. Before recommissioning, reconnect the machine to the mains according to regulations.
- When recommissioning, proceed according to the operating instructions..

Safety regulations

- Inspections according to legal and local obligatory regulations regarding accident prevention are carried out by the manufacturer or by authorised expert personnel. No guarantees whatsoever are valid for damage caused or favoured by the non-consideration of these directions for use.



INSTALLATION

INSTALLATION

Mechanical Installation

For installation of the filling panel observe the following:

- Use the filling panel only in clean and dry rooms.
- Observe the specified operating temperature (see "Technical Data")
- Mount the holding frame of the filling panel horizontally and in a user-friendly position. The wall must be capable of taking the load of the filling panel.
- Check all connections and retighten if necessary.
- Close filling valves, pressurize the system and check for leaks.
- Check the safety device.



Caution

Filling panels with direct filling connections: the load-bearing capacity of the wall must be sufficient to support the weight of the filling panel and the total weight of the maximum number of cylinders to be connected.

Electrical Installation

- The Start/Stop switch with operating lamp, which is integrated in the filling panel as standard, can be connected to the compressor control. The controls of L&W compressors are equipped with special terminals to provide the electrical connection of filling panels.
- Ensure the Start/Stop switch is designed for the control voltage of the compressor.
 - L&W - standard compressor control = 230 V
 - L&W - ECC compressor control = 24 V



Caution

Work on the electrical equipment of the compressor/filling panel may only be carried out by qualified electricians.



OPERATION

OPERATION

Filling Panel with One Pressure Range

This option allows the filling of 200 bar and 300 bar. The filling pressure is colour-coded to allow an optical differentiation. (Fig. black filling connections)

The DIN hand wheels have the following colour-codes:

- 200 bar: black
- 300 bar: red

Furthermore, the corresponding filling pressures at the compressor are marked by the bellows and labels.

Filling Panel: 4 x 200 bar



Filling Panel: 4 x 200 bar

Filling Panel with Two Pressure Ranges

200 bar / 300 bar parallel operation

This filling panel enables a parallel filling with 200 bar and 300 bar. For this purpose, the filling panel is equipped with a pressure reducer, a final pressure safety valve and a second filling pressure gauge.

The DIN hand wheels are colour-coded to allow an optical differentiation of the filling ranges:

- 200 bar: black
- 300 bar: red

Furthermore, the corresponding filling pressures at the compressor are marked by the bellows and labels.



Filling Panel: 4 x 300 bar and 2 x 200 bar



Fig. (left) Pressure reducer; (right) safety valve

OPERATION

Filling procedure



Caution! Fill only cylinders which:

- are marked with the test mark and the test stamp of the expert.
- have been hydrostatic tested (check last test date).
- are rated for the final pressure.
- are free from humidity.

1. Connect the closed compressed air cylinders to the filling connections
2. Open storage valve / start compressor
3. If the filling pressure exceeds the cylinder pressure (filling panel pressure gauge), open cylinders valves slowly
4. Move the levers of the connected filling valves to open position
5. Fill compressed air cylinders to the desired filling pressure
6. Close cylinders valves
7. Close the lever filling valves and the filling hoses will be automatically vented
8. Disconnect compressed air cylinders from the filling connections
9. Close storage valve / stop compressor to complete the filling process



MAINTENANCE AND SERVICE



MAINTENANCE AND SERVICE

Service, Repair and Maintenance

Carry out service and maintenance work exclusively when the compressor is stopped and depressurised. The unit should be leak-checked regularly. Leaks can be preferably localised by using a leak detector spray (if necessary, brush pipes with soapy water).

We recommend that only authorised L&W service technicians carry out service work on the bearing of the compressor (crankshaft and connecting rods).

We urgently recommend that all maintenance, repair and installation work must only be carried out by trained personnel. This is necessary because all maintenance work can not be explained exactly and detailed in this manual.

Only use authentic spare parts for service work.



Danger

Components under pressure, such as hose ends, can quickly come loose when manipulated and can cause potentially fatal injuries due to the pressure surge. Any work on system parts may only be performed in a pressure-compensated state.



Warning

The use of accessories that have not been tested can lead to death or serious injury or damage to the unit. Only use authentic spare parts for service work.



Warning





Carry out maintenance or service work when the unit is switched off and protected against unexpected restart.



MAINTENANCE AND SERVICE

Maintenance Overview

Maintenance work	Intervall	Quantity	Order No.
Check connections and mounting parts if installed correctly	After 15 operating hours, continuously once a year	-	-
The operator must perform an optical check of the hose pipes	Once a year	1 x each charging point	004959
Check safety valve function	Once a year	-	-
Check pressure lines for leakage	Once a year	-	-
Check lever filling valves	Once a year	Rep. Small Rep. Big	002451 002452
Clean pressure lines from contaminations	Depending on contamination, at least once a year	-	-
Sinter filter DIN filling connector	Every 2 years	1 x each charging point	002911
Change o-rings of the DIN filling connector	Every 2 years	1 x each charging point	001237

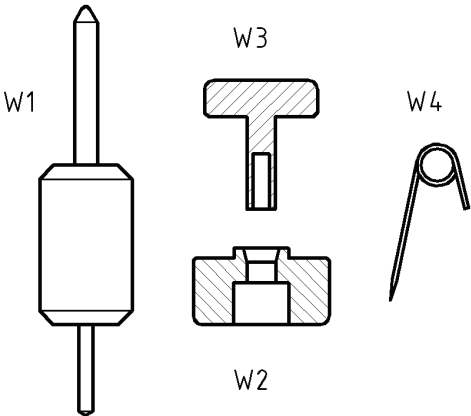
<p align="center">Overhaul Instructions for Toggle Filling Valve 002449 (HBV-121-A), 002450 (HBV-122-A) with Valve Body made from Aluminium</p>	
<p>Note on safety</p> <p>Special attention should be paid to statements preceded by the following signs:</p> <p> WARNING Indicates a strong possibility of severe personal injury or death if instructions are not followed.</p> <p> CAUTION Indicates that equipment or property damage can result if instructions are not followed.</p> <p> NOTE Gives helpful information.</p>	
<p>These overhaul instructions describe the dismantling and assembly of the toggle filling valve without inlet fitting and without filling tube or outlet fitting.</p> <p>For overhaul and repair are available</p> <ul style="list-style-type: none"> • Gasket kit 002451 (HBV-117-A). Therein included all O-rings as used • Maintenance kit 002452 (HBV-118-A). Therein included all wear parts and O-rings as used. • Lubricant (grease) MOLYKOTE 111 Compound. <p>Available are furthermore all parts according to parts list on page 12. Except the parts which are included in the maintenance and gasket kit.</p> <p> NOTE</p> <p>Before dismantling carefully clean the valve external, especially the inlet and outlet threads. Clean all single parts after dismantling. Use normal mild, fat-dissolving cleaning agent. No leach, no acid.</p> <p>At assembly observe the hints concerning MOLYKOTE 111 Compound for lubrication of O-rings and sliding parts. Further observe the information concerning the tightening torques.</p>	
	<p>1. Tools, necessary</p> <p>1.1 Standard Tools</p> <ul style="list-style-type: none"> 1 pcs open ended or ring spanner, jaw size 10 mm 1 pcs hexagon key L-wrench, hexagon 5 mm 1 pcs pin punch Ø 5mm 1 pcs hammer, light, 200 till 300 g 1 pcs torque wrench up to 20 Nm (2 kpm) with 1 pcs hexagon socket jaw width 10 mm 1 pcs hexagon bit , hexagon 5 mm <p>1.2 Special Tools</p> <ul style="list-style-type: none"> 1 pcs W1 Drift Ø 5 mm combined with centering pin Ø 3mm 1 pcs W2 Retainer 1 pcs W3 Plunger 1 pcs W4 Safety pin DIN 7404 size 3, 48 mm long

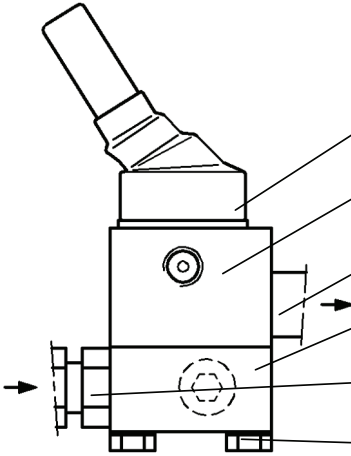
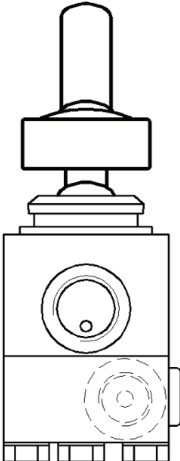
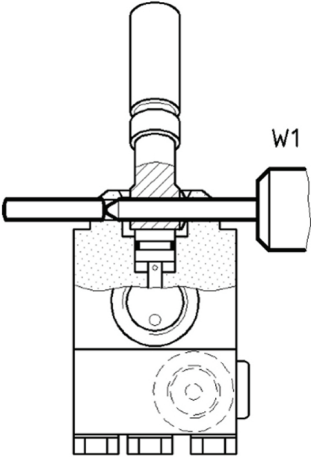

<p>Overhaul Instructions for Toggle Filling Valve 002449 (HBV-121-A), 002450 (HBV-122-A) with Valve Body made from Aluminium</p>		
	<p>2. Designation, Main Parts</p> <ul style="list-style-type: none"> toggle lever, moulded bellows valve body upper part, with : valve seat, valve pin, plunger (filling tube) valve body lower part with : valve spring, sealing cone, filter and retaining screw (inlet fitting) hexagon screw M6 x 30 mm 	
	<p>3. Valve, Dismantling</p> <p>⚠ NOTE Numbers stated behind the parts designation are related to the Parts List at page 12.</p> <p>3.1 Moulded bellows -1, removal First remove moulded bellow -1 from valve body upper part -7, than pull it from the toggle lever -2. Check moulded bellows -1 for damages as cracks or holes. If such existing, replace moulded bellows -1.</p> <p>⚠ NOTE Valve may be kept by hand for the above.</p>	
	<p>3.2 Toggle lever -2, removal Remove pin -3 with W1 drift Ø 5 mm as shown.</p> <p>⚠ NOTE Valve may be kept by hand for the above. If pin -3 cannot be moved by hand, use a light hammer and a pin punch Ø 5 mm.</p> <p>⚠ CAUTION For this fix the valve in a vice with smooth vice jaws or a firm cloth.</p>	

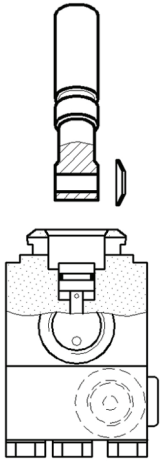
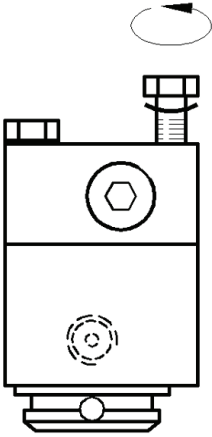
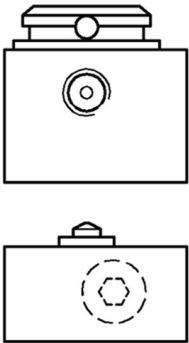
MAINTENANCE AND SERVICE

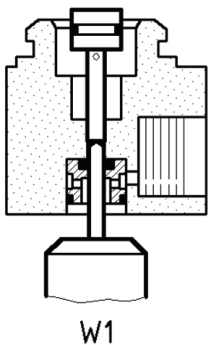
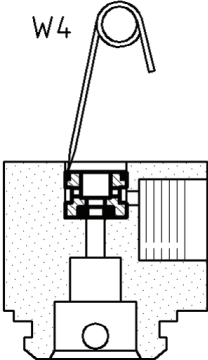
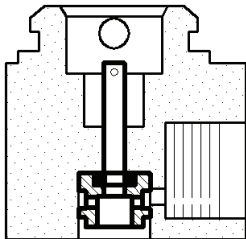
<p>Overhaul Instructions for Toggle Filling Valve 002449 (HBV-121-A), 002450 (HBV-122-A) with Valve Body made from Aluminium</p>	
	<p>3.2 continued Remove toggle lever -2 and disc spring -4.</p>
	<p>3.3 Valve body upper part-7 and Valve body lower part -15, separate</p> <p>⚠ CAUTION For this fix the valve in a vice with smooth vice jaws or a firm cloth.</p> <p>Unscrew the 3 pcs hexagon screws -21 with an open ended or ring spanner, jaw size 10 mm.</p> <p>⚠ CAUTION Press valve body upper part -7 and valve body lower part -15 together by hand at removal from the vice, to avoid the pop out of internal valve parts.</p>
	<p>3.3 continued place valve body with its lower part -15 onto a clean worktop and remove upper part -7.</p>

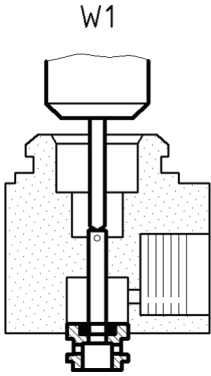
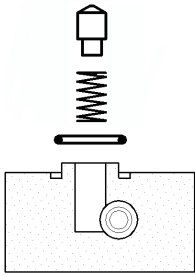
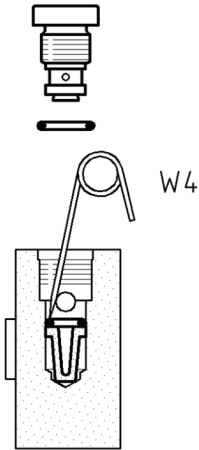
<p>Overhaul Instructions for Toggle Filling Valve 002449 (HBV-121-A), 002450 (HBV-122-A) with Valve Body made from Aluminium</p>	
 <p style="text-align: center;">W1</p>	<p>3.4 Valve pin -8 and Plunger -6, removal Remove valve pin -8 and plunger -15 by W1 centering pin \varnothing 3 mm as shown.</p> <p>⚠ CAUTION Act carefully to avoid damage on the seal seat of the valve pin -8.</p> <p>Remove O-ring -5, \varnothing 7 x \varnothing 1.5 mm from plunger -6.</p>
 <p style="text-align: center;">W4</p>	<p>3.5 O-ring -11, removal Remove O-ring -11, \varnothing 9 x \varnothing 1.5 mm with W4 safety pin.</p> <p>⚠ CAUTION Throw away O-ring -11, \varnothing 9 x \varnothing 1.5 mm. It is impaired by the above described procedure.</p>
	<p>3.6 Valve seat -10, removal Put valve pin -8, with venting bore on top, into valve body upper part -7 as shown.</p>

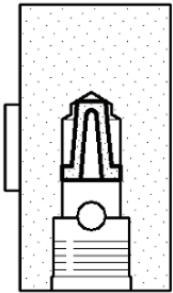
<p>Overhaul Instructions for Toggle Filling Valve 002449 (HBV-121-A), 002450 (HBV-122-A) with Valve Body made from Aluminium</p>		
 <p style="text-align: center;">W1</p>	<p>3.6 continued</p> <p>Remove valve seat -10 with W1 centering pin \varnothing 3 mm via valve pin -8. as shown</p> <p>Remove O-ring -9, \varnothing 3.68 x \varnothing 1.78 mm, from valve seat -10.</p>	
	<p>3.7 Sealing cone -12, Valve spring-13 and O-ring -14, removal</p> <p>Remove sealing cone -12 valve spring -13 O-ring -14, \varnothing 10.82 x \varnothing 1.78 mm from valve body lower part -15.</p>	
 <p style="text-align: right;">W4</p>	<p>3.8 Retaining screw -19, O-rings -18 and -17, Filter -16, removal</p> <p>⚠ CAUTION For this fix valve body lower part -15 with its narrow sides in a vice with smooth vice jaws or a firm cloth.</p> <p>Remove retaining screw-19 by a hexagon key L-wrench, hexagon 5 mm. Remove O-ring -18, \varnothing 8 x \varnothing 1.5 mm from retaining screw -19.</p> <p>Remove O-ring -17, \varnothing 4.47 x \varnothing 1.78 mm with W4 safety pin.</p> <p>⚠ CAUTION Throw away O-ring - \varnothing 4.47 x \varnothing 1.78 mm. It is impaired by the above described procedure.</p>	

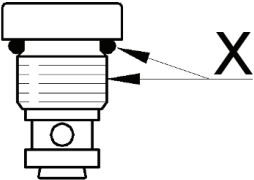
<p>Overhaul Instructions for Toggle Filling Valve 002449 (HBV-121-A), 002450 (HBV-122-A) with Valve Body made from Aluminium</p>	
	<p>3.8 continued Filter -16 removal, for this take valve body lower part -15, with filter chamber showing down, and tap the valve body lower part -15 on a clean surface, until the filter -16 falls out.</p>
	<p>4. Valve, Assembly</p> <p> NOTE Numbers stated behind the parts designation are related to the Parts List at page 12.</p> <p> NOTE</p> <p>Check all single parts for wear. Replace all worn or faulty parts.</p> <p>Always replace sealing cone 12.</p> <p>Always replace all O-rings.</p> <p>Use gasket kit HBV-117-A.</p> <p>Use maintenance kit HBV-118-A.</p> <p>Lightly lubricate threads and O-rings with MOLYKOTE 111 Compound</p>
	<p>4.1 Retaining screw -19 and O-ring -18 Put O-ring -18, Ø 8 x Ø 1.5 mm on retaining screw -19.</p> <p>X Lubricate O-ring 18 and thread of retaining screw -19.</p>

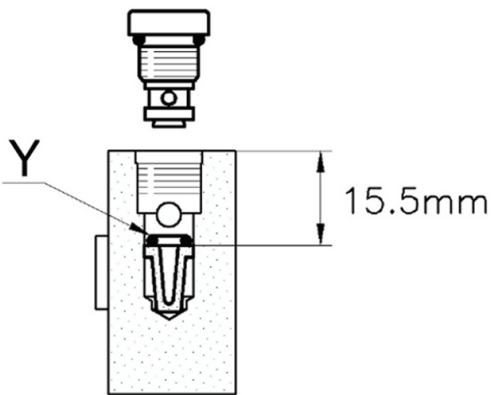
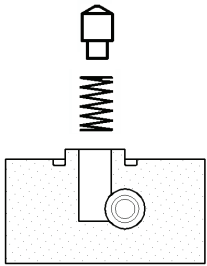
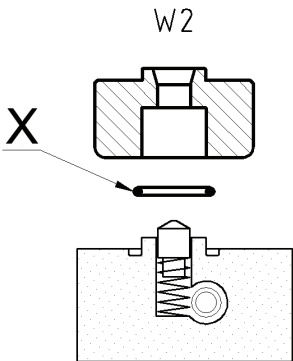
<p>Overhaul Instructions for Toggle Filling Valve 002449 (HBV-121-A), 002450 (HBV-122-A) with Valve Body made from Aluminium</p>		
	<p>4.2 Filter -16, O-ring -17, Retaining screw -19 with O-Ring -18 , assembly</p> <p>⚠ CAUTION For this fix valve body lower part -15 with its narrow sides in a vice with smooth vice jaws or a firm cloth.</p> <p>Insert filter -16, thereby do not tilt it. Move filter -16 down against block. Check mounting depth 15.5 mm.</p> <p>Y Put O-ring -17, Ø 4.47 x Ø1.78 mm not lubricated onto filter -16.</p> <p>Screw in retaining screw -19 with a hexagon key L-wrench, hexagon 5 mm.</p> <p>⚠ CAUTION Fasten retaining screw -19 by a torque wrench with 8.5 Nm (0.85 kpm).</p>	
	<p>4.3 Valve spring -13, Sealing cone -12, assembly</p> <p>Insert valve spring -13 and sealing cone -12 in valve body lower part -15.</p> <p>⚠ CAUTION Check sealing cone -12 for mobility with fingertip.</p>	
	<p>4.4 O-ring -14, assembly</p> <p>X Lubricate O-ring -14, Ø 10.82 x Ø 1.78 mm.</p> <p>Press O-ring -14 into groove of valve body lower part -15 with W2 retainer.</p>	

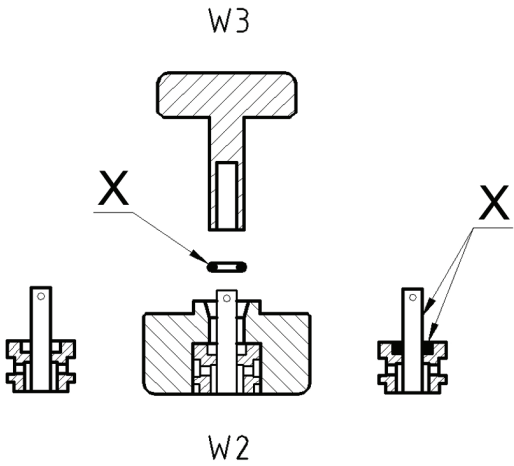
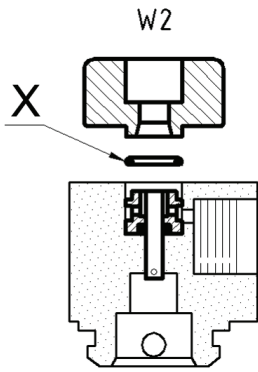
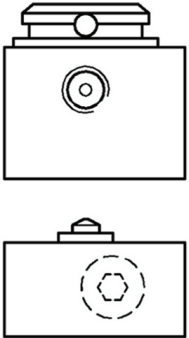
<p>Overhaul Instructions for Toggle Filling Valve 002449 (HBV-121-A), 002450 (HBV-122-A) with Valve Body made from Aluminium</p>		
	<p>4.5 Valve pin -8 and O-ring -9 assemble in Valve seat -10</p> <p>Put valve pin -8, with venting bore on top, into valve seat-10. Put W2 retainer over both parts as shown.</p> <p>X Lubricate O-ring -9, \varnothing 3.68 x \varnothing 1.78.</p> <p>Press O-Ring -9 with W3 plunger in valve seat -10.</p> <p>Remove W2 retainer.</p> <p>X Lubricate projecting part of the valve pin -8 and face of the valve seat -10.</p> <p>⚠ CAUTION In this connection do not move valve pin -10 to avoid that O-Ring -9 will be pushed out of valve seat -10.</p>	
	<p>4.6 Valve seat -10 with Valve pin -8 and O-ring -9, assembly</p> <p>Insert valve seat with mentioned parts into valve body upper part -7.</p> <p>X Lubricate O-ring -11, \varnothing 9 x \varnothing 1.5 mm and push it with W2 retainer into valve body upper part -10.</p>	
	<p>4.7 Valve body upper part -7 with Valve body lower part -15, match</p> <p>Place valve body upper part -7 on valve body lower part -15.</p>	

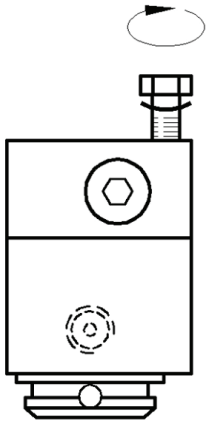
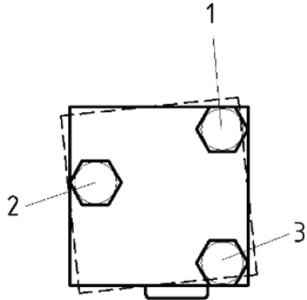
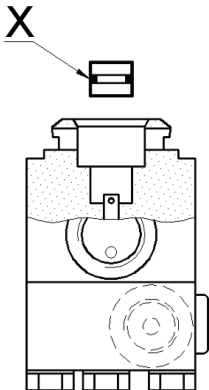
<p>Overhaul Instructions for Toggle Filling Valve 002449 (HBV-121-A), 002450 (HBV-122-A) with Valve Body made from Aluminium</p>		
	<p>4.7 continued</p> <p>Press valve body upper part -7 and valve body lower part -15 together by hand as shown.</p> <p>Screw in by hand or with an open ended or ring spanner, jaw size 10 mm, only 1 pcs hexagon screw -21 with curved spring washer -20 as shown.</p> <p>⚠ CAUTION</p> <p>For this fix only valve body upper part -7 in a vice with smooth vice jaws or a firm cloth.</p> <p>Valve body lower part -15 should be still moveable.</p>	
	<p>4.7 continued</p> <p>Align the sides of valve body upper part -7 with the sides of valve body lower part -15.</p> <p>Screw in by hand or with a open ended or ring spanner, jaw size 10 mm, the remaining 2 pcs hexagon screws -21 with curved spring washers -20</p> <p>⚠ CAUTION</p> <p>Tighten hexagon screws -21 in sequence 1-2-3 by torque wrench with 8.5 Nm (0.85 kpm).</p>	
	<p>4.8 Plunger -6 and O-ring -5, assembly</p> <p>X lubricate O-Ring -5, $\text{Ø } 7 \times \text{Ø } 1.5 \text{ mm}$ and put it on plunger -6.</p> <p>Push plunger -6 with O-ring -5 into valve body upper part -7.</p> <p>Move plunger -6 with W1 drift $\text{Ø } 5\text{mm}$ two to three times.</p>	

MAINTENANCE AND SERVICE

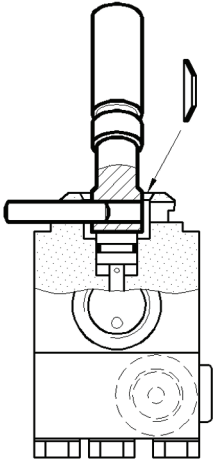
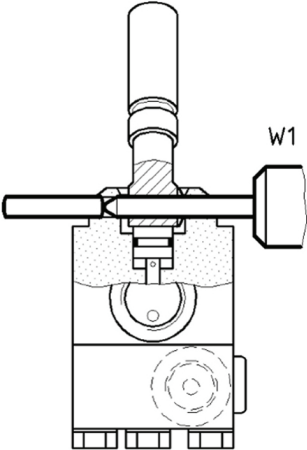
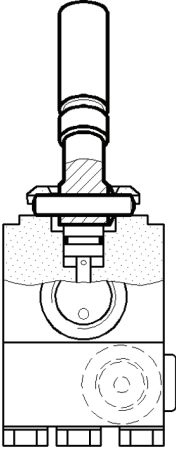
Overhaul Instructions for Toggle Filling Valve 002449 (HBV-121-A), 002450 (HBV-122-A) with Valve Body made from Aluminium		
	<p>4.9 Toggle lever -2, assembly</p> <p>⚠ CAUTION For this fix the valve in a vice with smooth vice jaws or a firm cloth.</p> <p>Lightly lubricate bore in toggle lever -2.</p> <p>Place toggle lever -2 in the valve that it points backward, related to the valve outlet.</p> <p>The bore in the valve body upper part -7 and in the toggle lever -2 should align.</p> <p>Insert pin -3 to the middle of the valve and insert the disc spring -4 as shown.</p> <p>If pin -3 cannot be moved by hand, push it in with a pin punch \varnothing 5mm and a light hammer.</p>	
	<p>4.9 continued</p> <p>Centre disc spring -4 with W1 drift \varnothing 5mm.</p> <p>⚠ CAUTION Thereby do not push out pin -3.</p>	
	<p>4.9 continued</p> <p>Fully push in pin - 3.</p> <p>If pin -3 cannot be moved by hand, push it in with a pin punch \varnothing 5mm and a light hammer.</p>	

MAINTENANCE AND SERVICE

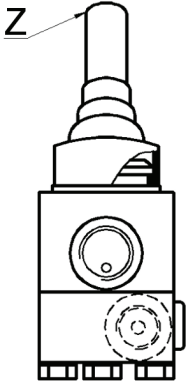
<p>Overhaul Instructions for Toggle Filling Valve 002449 (HBV-121-A), 002450 (HBV-122-A) with Valve Body made from Aluminium</p>		
	<p>4.10 Moulded bellows -1, assembly Z Moisten toggle lever-2 with a little soap water. Move moulded bellows -1 over toggle lever -2 and fix it at valve body upper part -7. Ensure that the beaded rim of moulded bellows -1 fits the groove on the valve body upper part -7 and check that the moulded bellows -1 is not twisted in itself. Move the toggle lever -2 several times for perfect function. Correct the installation of moulded bellows -1 if necessary. The assembly of the toggle filling valve is thereby completed.</p>	
<p>⚠ NOTE These Overhaul Instructions apply for toggle filling valves with serial-No. from 13 / 07501, June 2013 until</p>		
<p>Memos:</p>		

MAINTENANCE AND SERVICE

Overhaul Instructions for Toggle Filling Valve 002449 (HBV-121-A), 002450 (HBV-122-A) with Valve Body made from Aluminium

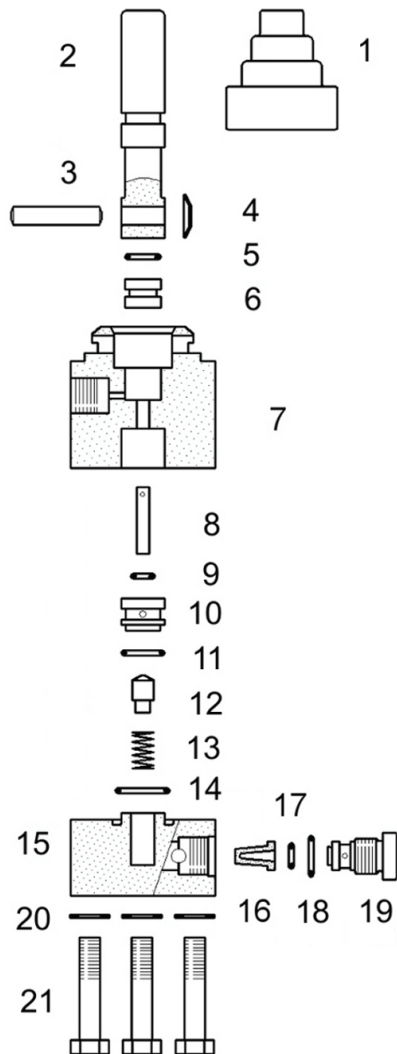

Parts List

Pos.	pcs.	Order-No.	Designation, Dimensions
1	1	000579	Moulded bellows, black
	or		
	1	000578	Moulded bellows, red
2	1	HBV-102-A	Toggle lever, kpl.
3	1	DIN 7	Pin, Ø 5 x 24 -A2
4	1	FDR-004-P	Disc spring
5*	1	ORI-002-P	O-ring Ø 7 x Ø 1.5
6*	1	HBV-014-P	Plunger
7	1	HBV-119-P	Valve body upper part
8*	1	HBV-115-P	Valve pin
9*	1	ORI-042-P	O-ring Ø 3.68 x Ø 1.78
10*	1	HBV-114-P	Valve seat
11*	1	HBV-004-P	O-ring Ø 9 x Ø 1.5
12*	1	HBV-116-P	Sealing cone
13	1	FDR-001-P	Valve spring Ø 5 x 11
14*	1	ORI-044-P	O-ring Ø 10.82 x Ø 1.78
15	1	HBV-120-P	Valve body lower part
16*	1	HBV-148-P	Filter, conical
17*	1	ORI-009-P	O-ring Ø 4.47 x Ø 1.78
18*	1	ORI-043-P	O-ring Ø 8 x Ø 1.5
19	1	HBV-149-P	Retaining screw G1/8
20	3	DIN 137	Spring washer A6 - A2
21	3	ISO 4014	Hexagon screw M6 x 30 - 8.8

*) = Included in maintenance or gasket kit

LENHARDT & WAGNER GMBH

Germany 68623 Lampertheim - An der Tuchbleiche 39
Tel: ..49 - (0)6256 - 85 88 00 Fax: ..49 - (0)6256 - 85 88 014
E-Mail: service@lw-compressors.com

All rights according to DIN 34 reserved. Subject to changes.



MAINTENANCE RECORDS



MAINTENANCE RECORDS

Maintenance work

Description	Date, signature



MAINTENANCE RECORDS

Replaced Parts

Designation	Part number	Date, signature



OPTIONS

STORAGE CONTROL

Storage tank filling

Check if all lever filling valves are closed before filling of the storage tank to the desired operating pressure. Open the storage cylinder valves and the hand wheel valve on the filling panel and start the compressor.

Read the storage pressure on the pressure gauge (Fig. 1).

Close the hand wheel valve (or also the storage cylinder valves) when the desired storage pressure is reached.

Operation

Use the storage pressure to fill the cylinders as follows:

- Connect the cylinders being filled to the filling valves according to chapter "Operation"
- Ensure that the cylinder valves are open
- Check the storage pressure with the pressure gauge (Fig. 1)
- Open the hand wheel valve by turning the black hand wheel (Fig.2)
- Open the cylinder valves and turn the respective lever filling valves
- The overflow from the storage to the filling panel starts
- Close the hand wheel valve after overflow (if the storage pressure is not sufficient, close the hand wheel valve and start the compressor)
- Close cylinder valves if wanted



Fig. 1 - Hand wheel valve and pressure gauge

Hand wheel valve

Open the hand wheel valve:

- Turn black hand wheel valve anticlockwise

Close the hand wheel valve:

- Turn black hand wheel valve clockwise



Fig. 2 - Hand wheel valve

STORAGE CONTROL

Hand wheel valve

The hand wheel valve is maintenance-free.

Spare parts are available in the L&W stock and can be ordered any time.

Best.-Nr. / Order No.	Designation
001476	Complete Unit



Rubber Hand Wheel

Best.-Nr. / Order No.	Designation
006748	Complete Unit

includes:

005010	Sticker for Hand Wheel Valve Cap
002389	Upper Cap



Top section

Best.-Nr. / Order No.	Designation
000573	Complete Unit

includes:

005010	Sticker for Hand Wheel Valve Cap
002389	Upper Cap
001233	O-Ring B6—10x2 NBR90
-	DS 15/10/2
000237	Ball Bearing
-	Housing Upper Section



Lower spindle

Best.-Nr. / Order No.	Designation
000571	Complete Unit



STORAGE CONTROL

Storage Pressure Gauge and Fittings



000899

000662

Best.-Nr. / Order No.	Benennung	Description
000662	Manometer 0-400 bar	Pressure Gauge 0-400 bar
000765	Schneidring PSR 08 LX	Olive Seal PSR 08 LX
000766	Mutter M08LCFX	Nut M08LCFX
000899	Schottverschraubung 8L	Bulkhead Fitting 8L

THROTTLE VALVE

Adjustment Charging Rate via Throttle Valve

The flow rate can be steplessly adjusted by the throttle valve. The throttle valve can be individually adjusted to the number of cylinders and to the available filling pressure.

Respect the instructions of the storage tank manufacturer. The filling pressure rise can be read on the filling pressure gauge.



Stepless adjustable throttle valve

Spare parts list

Order No.	Description
002265	Throttle valve



INLET PRESSURE REDUCTION

Function

If the system pressure (inlet pressure at the filling panel) is higher than the desired filling pressure, an inlet pressure reducer and a correspondent safety valve can be installed alternatively to an external pressure reducing station.

Use the next bigger filling panel housing for filling panels below four filling connections.



Pressure reducer (left) & safety valve (right)

Spare parts list

Order No.	Description
001427	Pressure reducer with adjusting screw
000761	Elbow connection WE 8L-1/4"
004379	Inlet connection pressure reducer 8L
000766	Nut 8L
000765	Olive Seal 8L
000233	Safety Valve Base
000739	Connection GE 8L-1/4"
001814	Safety valve 225 bar (CE)
000553	Safety valve 225 bar (TÜV)
001816	Safety valve 330 bar (CE)
000556	Safety valve 330 bar (TÜV)
001244	O-ring safety valve flange



Safety Valve Base

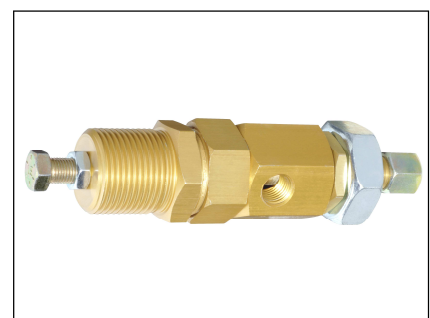

Pressure reducer with adjusting screw

HR HOUR COUNTER / EMERGENCY STOP SWITCH

Hour Counter

Monitoring of the hour counter: connect the hour counter, which is installed to the filling panel to the compressor control or to an external control.

Spare parts list

Order No.	Description
002089	Hour counter 230V



Hour Counter

Emergency Stop Switch

Increase the safety standard of your filling system by using an emergency stop switch. This can be integrated in the emergency stop line of the compressor or in an external control.

Spare parts list

Order No.	Description
003121	Emergency Stop Switch, complete

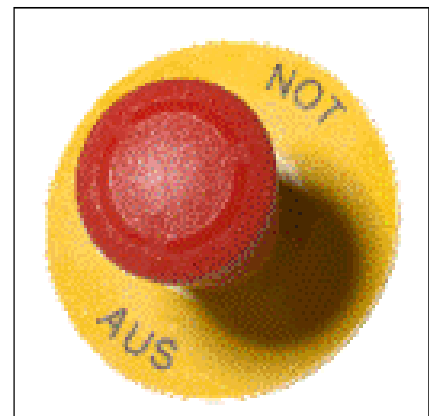

Emergency Stop Switch

Anti-whip connections

The flow restrictor of the anti-whip connections avoids a “whipping” of the filling hose during opening of the lever filling valve without connected cylinder.

When connecting the respective cylinder valve to the anti-whip connection, the flow restrictor opens and the filling procedure can be done.

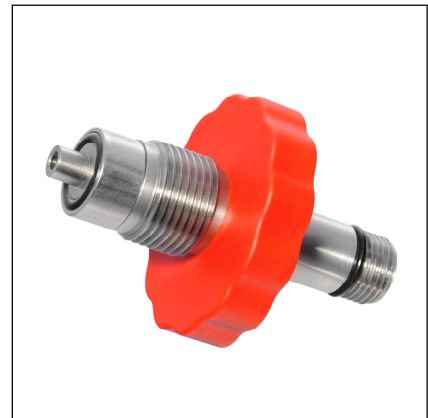

Anti-whip connection with hand wheel
DIN 300 bar

Spare parts list

Order No.	Description
000701	Anti-whip Connection 200 bar without Hand Wheel
002303	Anti-whip Connection 200 bar with Hand Wheel
000702	Anti-whip Connection 300 bar without Hand Wheel
002304	Anti-whip Connection 300 bar with Hand Wheel

90° elbows for filling hoses

The elbow connection to connect the lever filling valve to the filling hose can be easily retrofitted to all L&W filling panels with filling hoses.



Winkelverschraubung M16x1,5

Spare parts list

Order No.	Description
000797	Elbow connection 10L



LENHARDT & WAGNER GMBH

Manufacturer in terms of 97/23/EC

The full name and address of the manufacturer is:

Lenhardt & Wagner GmbH

An der Tuchbleiche 39
68623 Hüttenfeld / Germany

Phone: +49 (0) 62 56 - 85 88 0 - 0

Fax: +49 (0) 62 56 - 85 88 0 - 14

E-Mail: service@lw-compressors.com

Internet: www.lw-compressors.com





**ERSATZTEILLISTEN / SPARE PARTS LISTS
DETAILANSICHTEN / DETAILED VIEWS**



Inhaltsverzeichnis - Table of Contents

Kipphebelventil mit Verschraubungen - Lever Valve cw Connections	1
Füllschlauch - Filling Hose	3
Direktanschluss - Direct BA Connection	5
Druckminderer - Pressure Reducer	7
Sicherheitsventil - Safety Valve	9
Drosselventil - Throttle Valve	11
Rundventil ohne Entlüftung - Cascade Valve Non-Venting	13
Manometer 250 bar und 300 bar - Pressure Gauge 250 bar und 300 bar	15
Manometer Speicher - Pressure Gauge Tank.....	16
Start-Stopp Schalter - Start-Stop Buttons	17
Start-Stopp Schalter ECC - Start-Stop Buttons ECC.....	19



ERSATZTEILLISTE / SPARE PART LIST

Kipphebelventil mit Verschraubungen / Lever Valve c/w Connections

Best.-Nr. / Order No.	Benennung	Description
000498	U-Scheibe, DIN 125 A6	Washer, DIN 125 A6
000580	Schalldämpfer, Kipphebelventil, G1/8"	Silencer Lever Filling Valve, G1/8"
000753	Verschraubung, T08L	Elbow Connection, T08L
000760	Verschraubung, W08LCFX	Elbow Connection, W08LCFX
000765	Schneidring, PSR 08 LX	Olive Seal, PSR 08 LX
000766	Mutter, M08LCFX	Union Nut, M08LCFX
000949	Flachkopfschraube, M6x12mm DIN6912 8.8 ZN	Pan Head Bolt, M6x12mm DIN6912 8.8 ZN
002449	Kipphebelventil / Füllleiste 200 bar	Lever Valve (filling panel) 200bar
002450	Kipphebelventil / Füllleiste 300 bar	Lever Valve (filling panel) 300bar

DETAILANSICHT / DETAILED VIEW

Kippschleppventil mit Verschraubungen / Lever Valve c/w Connections

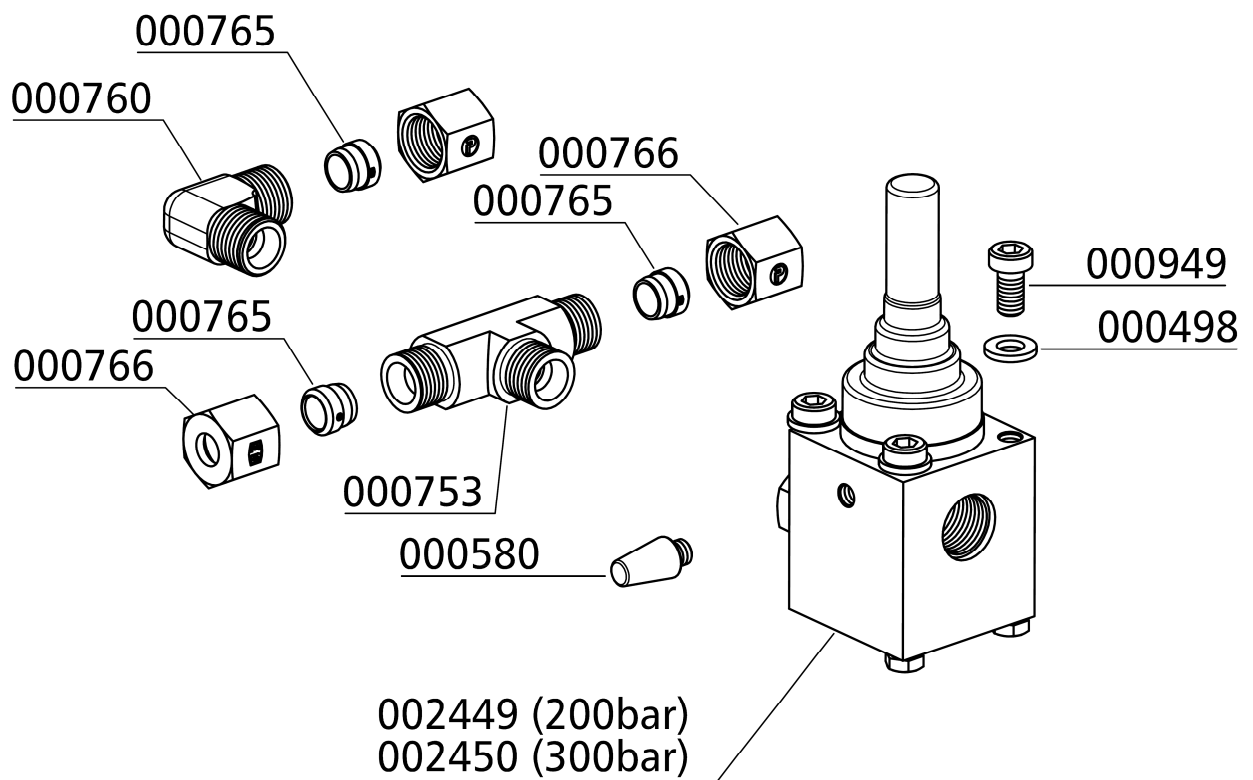



ERSATZTEILLISTE / SPARE PART LIST

Füllschlauch / Filling Hose

Best.-Nr. / Order No.	Benennung	Description
000213	Handrad, schwarz DIN 477	Hand Wheel DIN 200 bar, black
000215	Handrad rot DIN 477	Hand Wheel DIN 300 bar, red
000695	Füllanschluss, 200 bar, AG M16X1,5	Filling Connection, 200 bar, M16X1,5 (female)
000697	Füllanschluss, 300 bar, AG M16X1,5	Filling Connection, 300 bar, M16X1,5 (female)
000701	Sicherheitsfüllanschluss, 200 bar, AG M16X1,5	Anti Whip Connection, 200 bar, M16X1,5 (female)
000702	Sicherheitsfüllanschluss, 300 bar, AG M16X1,5	Anti Whip Connection, 200 bar, M16X1,5 (female)
000797	Verschraubung mit fester Mutter	Elbow Connection c/w fixed nut
001237	O-Ring, 12,37 x 2,62 NBR90	O-Ring, 12,37 x 2,62 NBR90
001238	O-Ring, 12,42 x 1,78 NBR90	O-Ring, 12,42 x 1,78 NBR90
001435	Hochdruckschlauch, 1000mm, beidseitig 10L	HP Hose, 1000mm, both ends 10L fixed
002811	Hochdruckschlauch, 8S/10L, drehbar	HP-Hose, 8S/10L, rotatable
002911	Sinterfilter, Ø6,3 x 8mm	Sintered Filter, Ø6,3 x 8mm
005439	Verschraubung, Fülleisten, GE M16x1,5/10L	Connection for Filling Panels, GE M16x1,5/10L

DETAILANSICHT / DETAILED VIEW

Füllschauch / Filling Hose

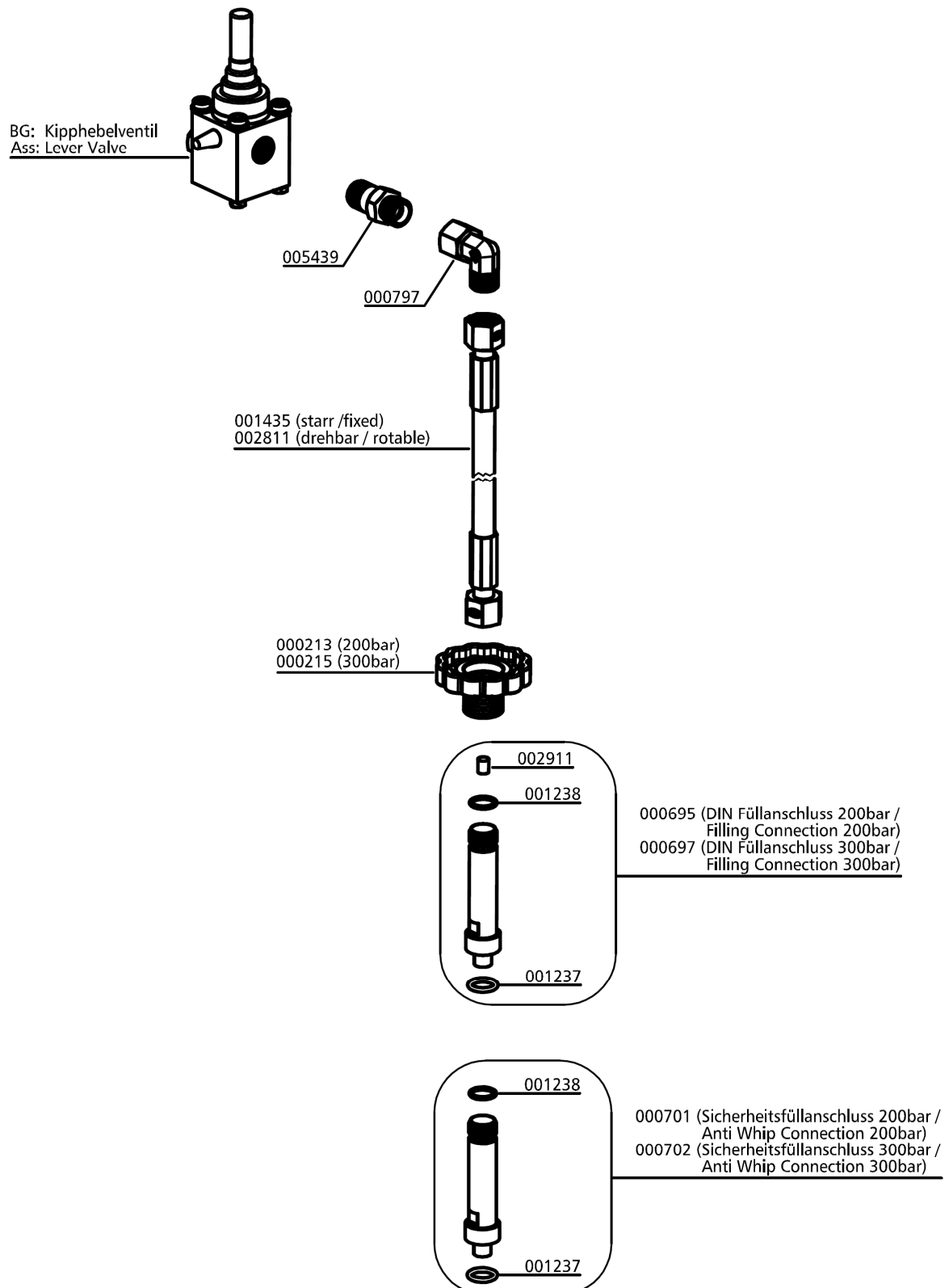



ERSATZTEILLISTE / SPARE PART LIST

Direktanschluss / Direct BA Connection

Best.-Nr. / Order No.	Benennung	Description
000213	Handrad, schwarz DIN 477	Hand Wheel DIN 200 bar, black
000215	Handrad rot DIN 477	Hand Wheel DIN 300 bar, red
000695	Füllanschluss, 200 bar, AG M16X1,5	Filling Connection, 200 bar, M16X1,5 (female)
000697	Füllanschluss, 300 bar, AG M16X1,5	Filling Connection, 300 bar, M16X1,5 (female)
000701	Sicherheitsfüllanschluss, 200 bar, AG M16X1,5	Anti Whip Connection, 200 bar, M16X1,5 (female)
000702	Sicherheitsfüllanschluss, 300 bar, AG M16X1,5	Anti Whip Connection, 200 bar, M16X1,5 (female)
001237	O-Ring, 12,37 x 2,62 NBR90	O-Ring, 12,37 x 2,62 NBR90
001238	O-Ring, 12,42 x 1,78 NBR90	O-Ring, 12,42 x 1,78 NBR90
001408	Verschlusskappe, G5/8"IG,	Protection Cap G5/8", female
001415	Blindniete, Ø4 x 24	Rivet, Ø4 x 24
001416	O-Ring, 15 x 2,5 NBR70	O-Ring, 15 x 2,5 NBR70
001417	Halterung für Verschlusskappe, ohne Niete & O-Ring	PVC Holder for Cap, w/o Rivet & O-Ring
001418	Halterung für Verschlusskappe, mit Niete (c/w rivet) & O-Ring	PVC Holder for Cap, c/w Rivet and O-Ring
002911	Sinterfilter, Ø6,3 x 8mm	Sintered Filter, Ø6,3 x 8mm

DETAILANSICHT / DETAILED VIEW

Direktanschluss / Direct BA Connection

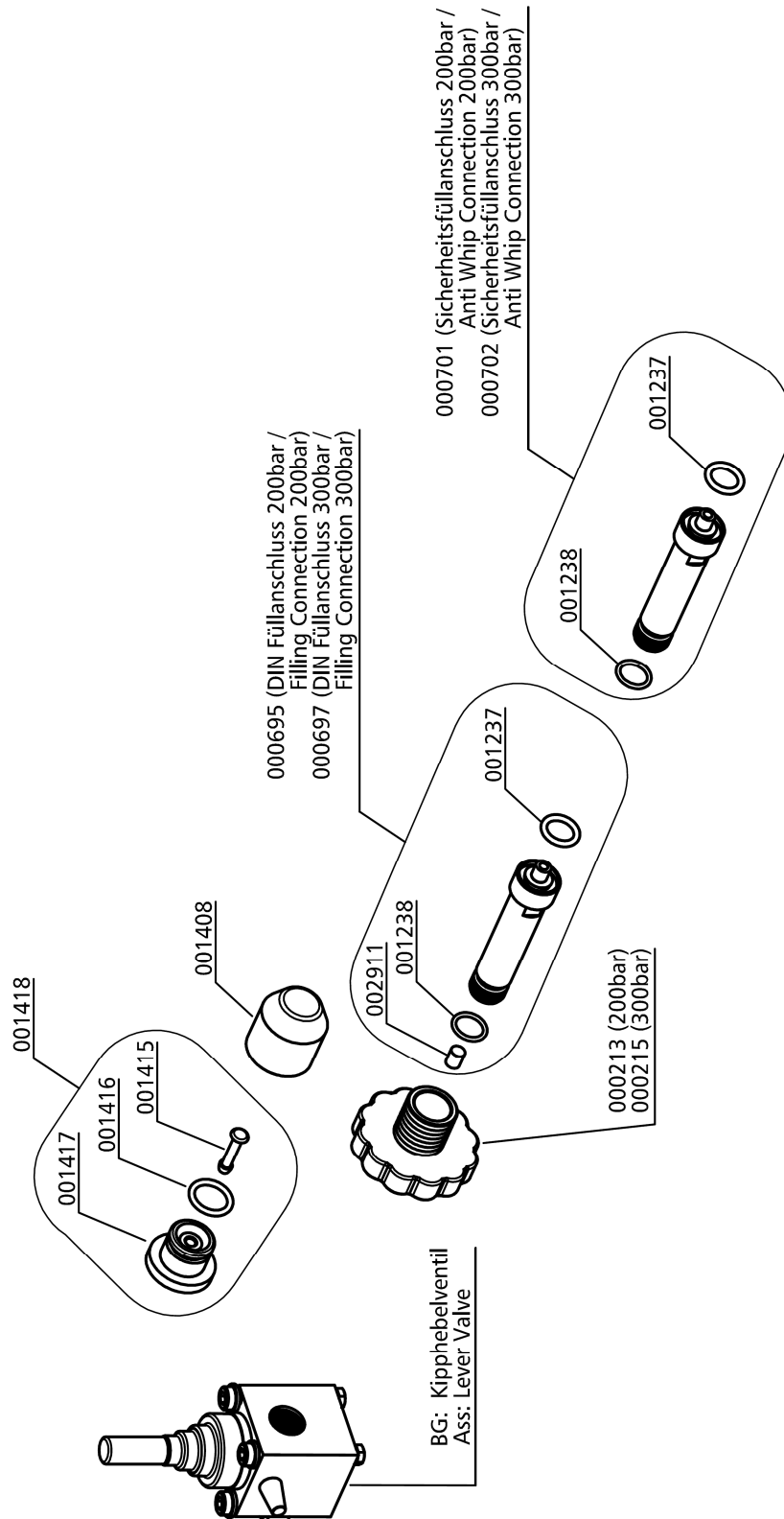



ERSATZTEILLISTE / SPARE PART LIST

Druckminderer / Pressure Reducer

Best.-Nr. / Order No.	Benennung	Description
000765	Schneidring, PSR 08 LX	Olive Seal, PSR 08 LX
000767	Mutter, 8S M16x1,5 IG	Union Nut, 8S M16x1,5 IG
001428	Druckminderer	Pressure Reducer
004932	Verschraubung, GA 1/4"NPT / 8S	Connection, GA 1/4"NPT / 8S
004935	Verschraubung, WE08S-1/4" NPT	Elbow Connection, WE08S-1/4" NPT

DETAILANSICHT / DETAILED VIEW

Druckminderer / Pressure Reducer

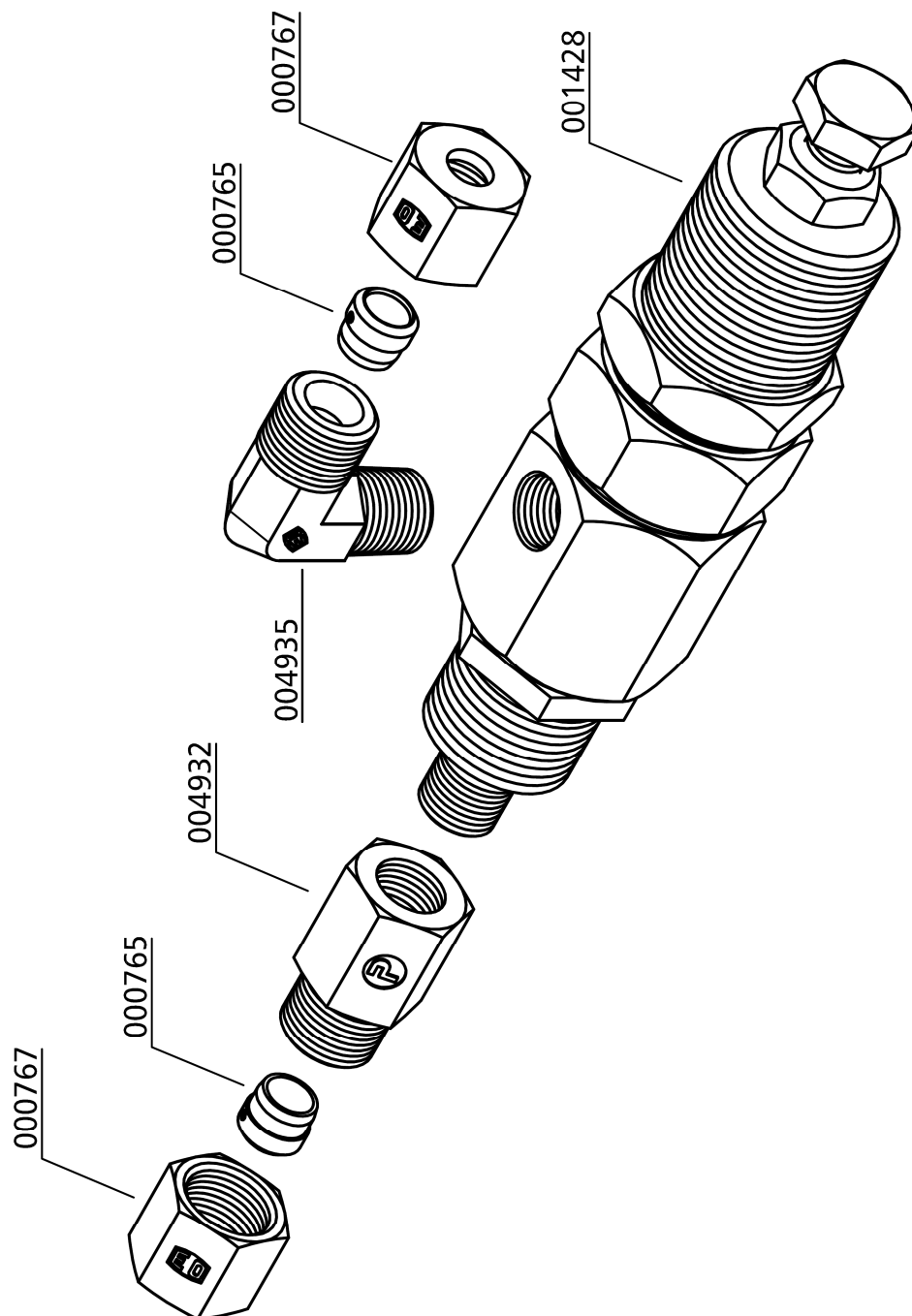

Sicherheitsventil / Safety Valve

Best.-Nr. / Order No.	Benennung	Description
000233	Sockel für Sicherheitsventil mit TÜV, x G1/4" seitlich 180°	Base for Safety Valve TÜV type
000553	Sicherheitsventil 225bar mit TÜV	Safety Valve 225bar c/w TÜV
000554	Sicherheitsventil 250bar mit TÜV	Safety Valve 250bar c/w TÜV
000555	Sicherheitsventil 300bar mit TÜV	Safety Valve 300bar c/w TÜV
000556	Sicherheitsventil 330bar mit TÜV	Safety Valve 330bar c/w TÜV
000557	Sicherheitsventil 350bar mit TÜV	Safety Valve 350bar c/w TÜV
000738	Verschraubung, GE08LRFCX	Connection, GE08LRFCX
000761	Winkelverschraubung, WE08LRA3CX	Elbow Connection, WE08LRA3CX
000765	Schneidring, PSR 08 LX	Olive Seal, PSR 08 LX
000766	Mutter, M08LCFX	Nut, M08LCFX
001043	Zylinderschraube, M8x35mm DIN912 8.8 ZN	Allen Bolt, M8x35mm DIN912 8.8 ZN
001058	Zylinderschraube, M8x70mm DIN912 8.8 ZN	Allen Bolt, M8x70mm DIN912 8.8 ZN
001160	Hutmutter, M8 DIN1587 ZN	Domed Nut, M8 DIN1587 ZN
001181	U-Scheibe,, A8 DIN125 ZN	Washer, A8 DIN125 ZN
001244	O-Ring, Flansch Sicherheitsventil	O-Ring, Flange Safety Valve
001814	Sicherheitsventil 225bar mit CE	Safety Valve 225bar with CE
001815	Sicherheitsventil 250bar mit CE	Safety Valve 250bar with CE
001816	Sicherheitsventil 330bar mit CE	Safety Valve 330bar with CE
001817	Sicherheitsventil 350bar mit CE	Safety Valve 350bar with CE

DETAILANSICHT / DETAILED VIEW

Sicherheitsventil / Safety Valve

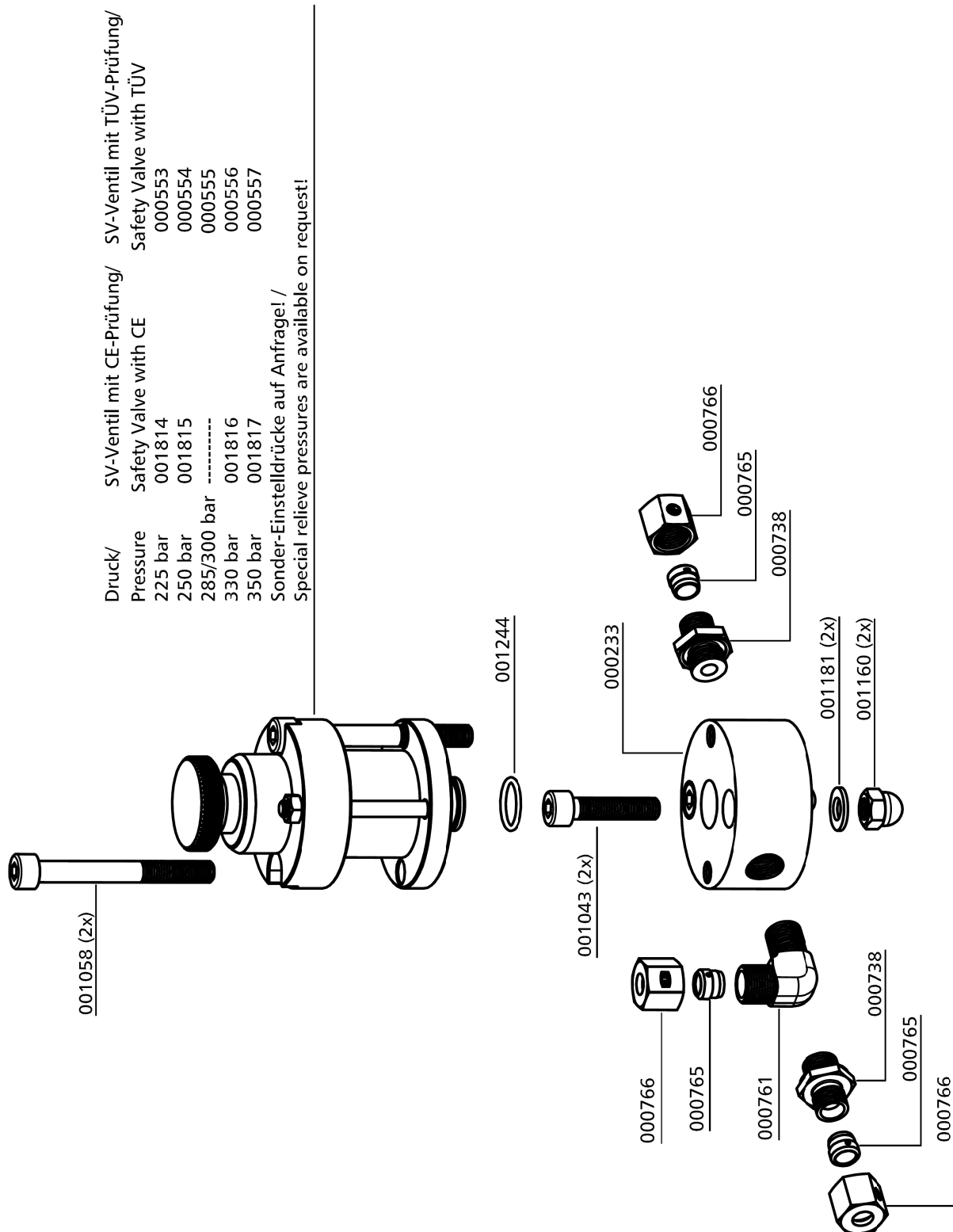



ERSATZTEILLISTE / SPARE PART LIST

Drosselventil / Throttle Valve

Best.-Nr. / Order No.	Benennung	Description
000738	Verschraubung, GE08LRFCX	Connection, GE08LRFCX
000765	Schneidring, PSR 08 LX	Olive Seal, PSR 08 LX
000766	Mutter, M08LCFX	Union Nut, M08LCFX
001200	U-Scheibe, A19 DIN125 ZN	Washer, A19 DIN125 ZN
002265	Drosselventil, ohne Befestigungssatz, max 345 bar	Throttle valve, w/o mount kit, max 345 bar

DETAILANSICHT / DETAILED VIEW

Drosselventil / Throttle Valve

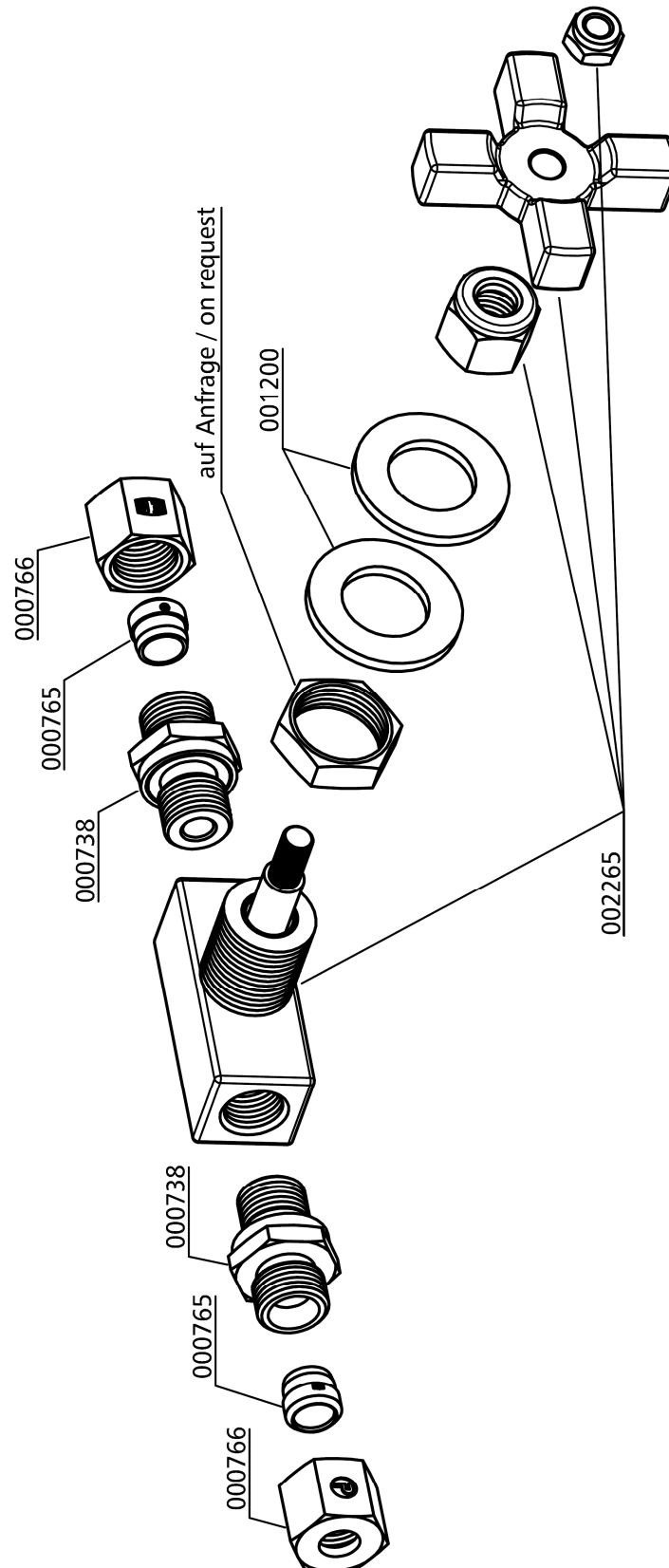



ERSATZTEILLISTE / SPARE PART LIST

Rundventil ohne Entlüftung / Cascade Valve non-venting

Best.-Nr. / Order No.	Benennung	Description
000751	Verschraubung mit Mutter & Schneidringe, TE 08 LRCFX	Connection incl nut&olive seal, TE 08L RCFX
000758	Verschraubung, LE 08 LR	T-Connection, LE 08 LR
000765	Schneidring, PSR 08 LX	Olive Seal, PSR 08 LX
000766	Mutter, M 08 LCFX	Nut, M08 LCFX
001477	Drehventil ohne Entlüftung inkl. Handrad, 350 bar	Cascade Valve non-venting c/w Hand Wheel, 350 bar

DETAILANSICHT / DETAILED VIEW

Rundventil ohne Entlüftung / Cascade Valve non-venting

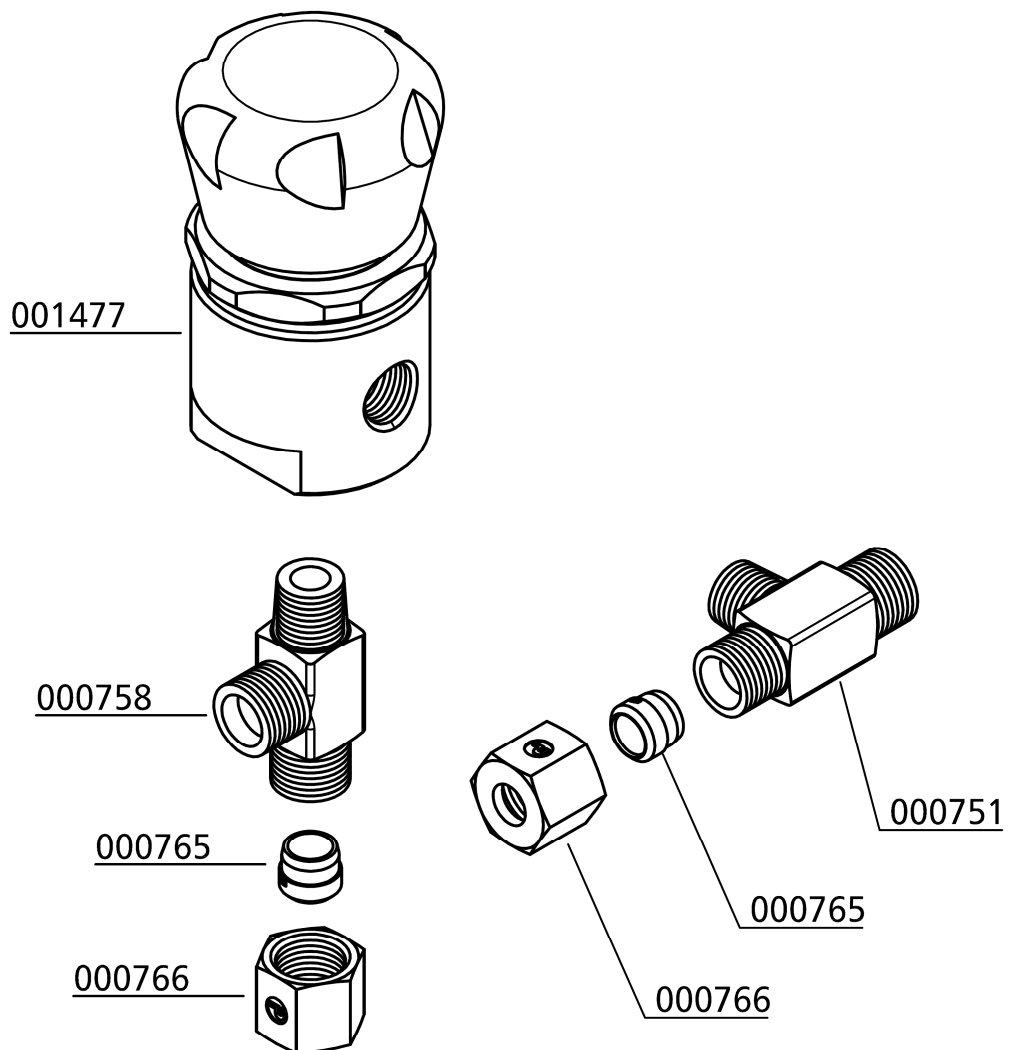

ERSATZTEILLISTE / SPARE PART LIST

Manometer 250 bar und 400 bar / Pressure Gauge 250 bar und 400 bar

Best.-Nr. / Order No.	Benennung	Description
000667	Einbaumanometer mit Befestigungsbügel, 0-250bar, Ø100mm	Pressure Gauge c/w Mounting Brackets, 0-250bar, Ø100mm
000668	Einbaumanometer mit Befestigungsbügel, 0-400bar, Ø100mm	Pressure Gauge c/w Mounting Brackets, 0-400bar, Ø100mm
000772	Verschraubung Manometer, MAV08LROMDCF	Connection Pressure Gauge, MAV08LROMDCF
000777	Dichtring für Manometerverschraubung, DK11/4CFX	Seal Ring for Pressure Gauge, DK11/4CFX

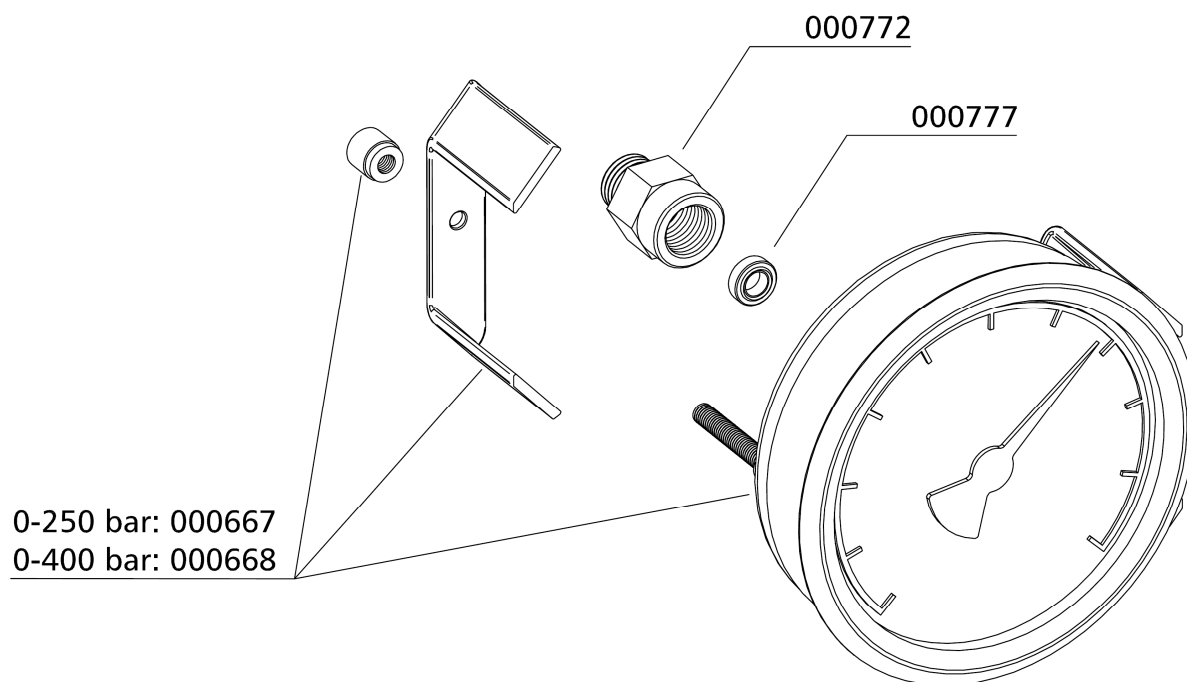

ERSATZTEILLISTE / SPARE PART LIST

Manometer Speicher / Pressure Gauge Tank

Best.-Nr. / Order No.	Benennung	Description
000662	Einbaumanometer mit Befestigungsbügel, 0-400bar Ø63mm	Press. Gauge c/w fixing strap, 0-400bar Ø63mm
000760	Verschraubung, W08LCFX	Elbow Connection, W08LCFX
000765	Schneidring 8mm, PSR 08 LX	Olive Seal 8mm, PSR 08 LX
000766	Mutter, M08LCFX	Nut, M08LCFX
000773	Manometerverschraubung mit fester Mutter	Connection Pressure Gauge IG 1/4" MAVE 08 LR c/w fixed nut

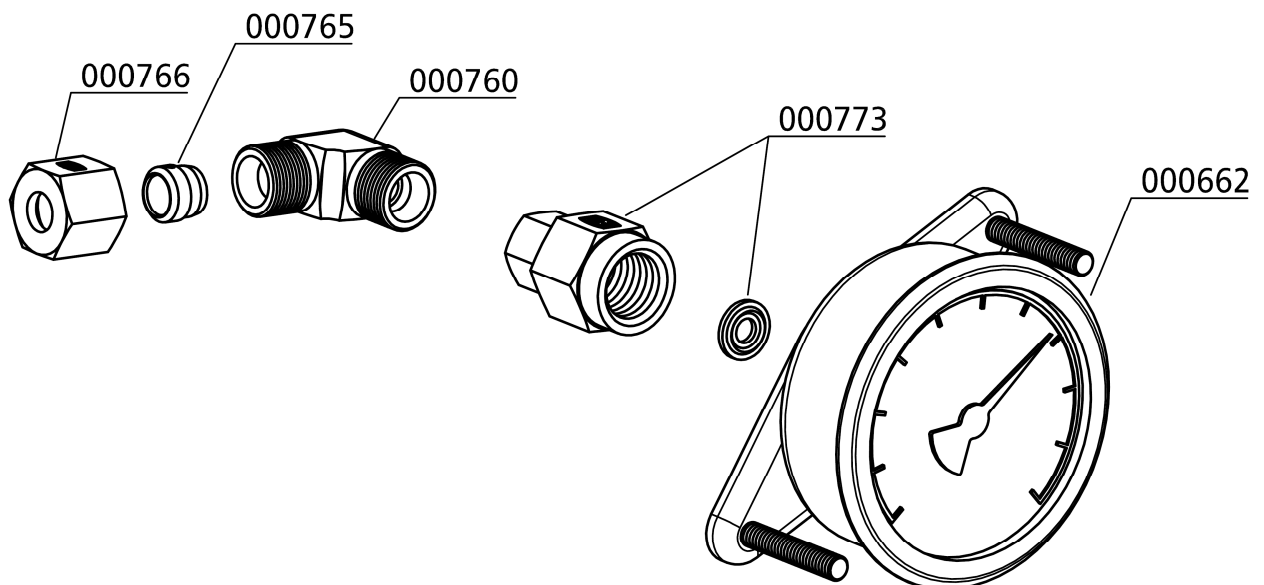



ERSATZTEILLISTE / SPARE PART LIST

Start/Stopp-Schalter / Start/Stop-Buttons

Best.-Nr. / Order No.	Benennung	Description
002942	Start / Stopp Schalterelemente	Start / Stop Buttons
001841	Doppeldrucktaster	Double Pushbutton
004688	Befestigungsadapter Wahlschalter	Clamp adapter selector switch
004691	Schließer-Kontakt, Front	Closing Contact (front)
004692	LED Element weiß	LED Element
004694	Öffner-Kontakt Aus-Taster	Breaker, button

DETAILANSICHT / DETAILED VIEW

Start/Stopp-Schalter / Start/Stop-Buttons

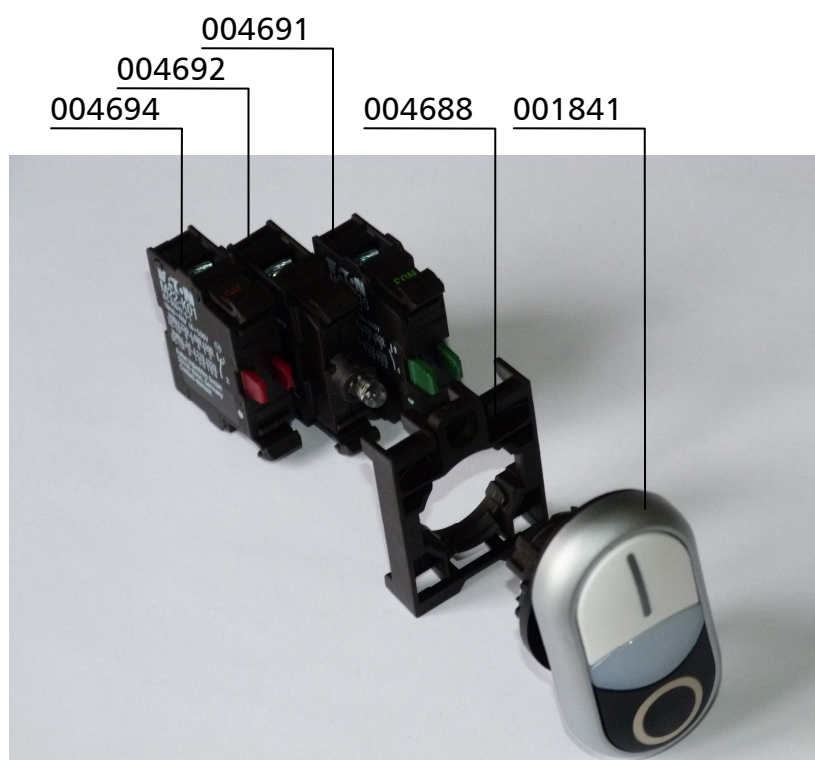



ERSATZTEILLISTE / SPARE PART LIST

Start/Stop-Schalter (ECC) / Start/Stop-Buttons (ECC)

Best.-Nr. / Order No.	Benennung	Description
002943	Start / Stopp Schalterelemente für ECC	Start / Stop Buttons (ECC Control)
004688	Befestigungsadapter Wahlschalter	Clamp adapter selector switch
004691	Schließer-Kontakt, Front	Closing Contact (front)
007953	Doppeldrucktaster	Double Pushbutton
007954	LED Element weiß	LED Element

DETAILANSICHT / DETAILED VIEW

Start/Stopp-Schalter (ECC) / Start/Stop-Buttons (ECC)

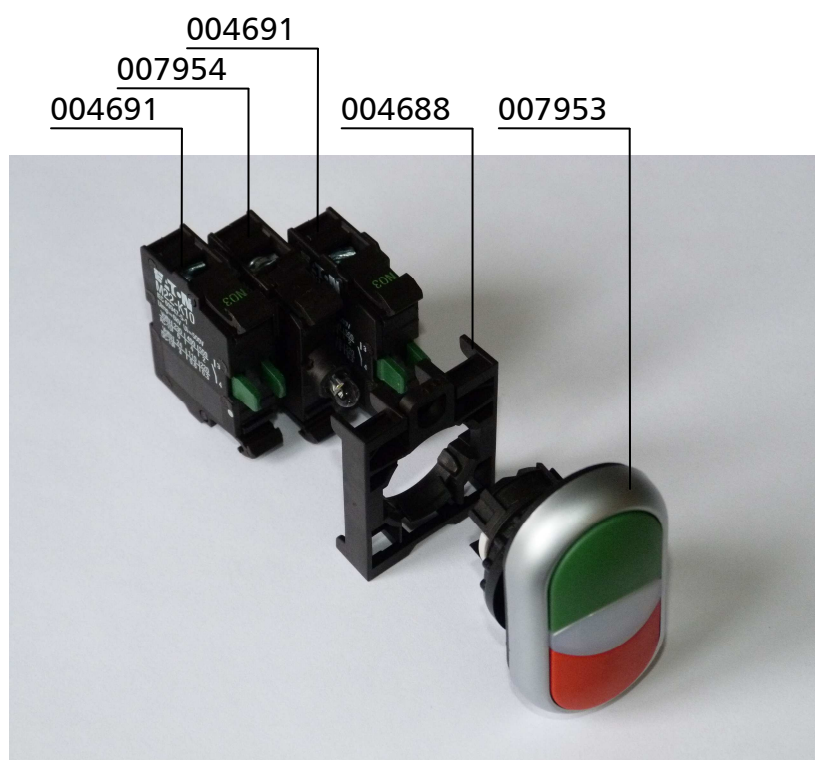
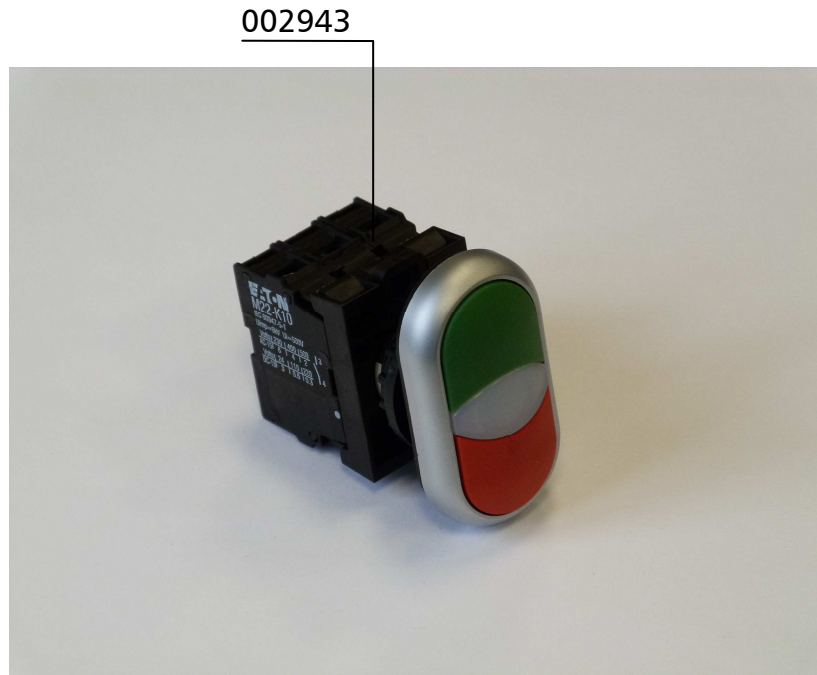



ATTACHMENT

E

Lenhardt & Wagner GmbH

**An der Tuchbleiche 39
D-68623 Lampertheim – Hüttenfeld**

www.lw-compressors.com



Operating Instruction

Safety valve

Typ:

SiV2 BKZ 989 TÜV.SV.12-989.5.G.V.P CE 0091 AlMgSi1 F31 1100* Lenhardt & Wagner

SiV BKZ TÜV.SV.14-1140.5.G.V.p CE 0091 AlMgSi1 F31 1100* Lenhardt & Wagner

Set pressure:	see mark (hand wheel on top of valve)
Maximum outflow:	Set pressure 100-159 bar: 750 l / min Set pressure 160-350 bar: 1.100 l / min
Suitable media:	Media-resistant, non-corrosive gases

The safety valve is used for protection of pressurized components, eg pipelines, pressure vessels, or the compressor itself.

The hand wheel on the top of the safety valve is marked with the adjusted set pressure.



Safety valve with socket

- 1) *Identification of set pressure*
- 2) *Seal*
- 3) *Fixing screws¹*
- 4) *Venting screw (hand wheel)*
- 5) *Identification serial number*
- 6) *Socket for safety valve*

¹ und die Anforderungen des AD 2000 Merkblatts W7 erfüllen. Schaftlänge 70mm. The fixing screws M8 must be strength class 8.8 and meet the requirements of Merkblatt AD 2000 leaflet W7. Shaft length 70mm.

In order to prevent manipulation of the set pressure, all safety valves are factory fitted with a seal.

A safety valve on which the seal has been removed, must be returned before further use to the manufacturer for repair / adjustment.

In addition, the safety valve has a venting device (hand wheel).

In the rotation direction clockwise, the safety valve and herewith also the filter housing of the final stage could be completely vented.

During normal operation, the screw is unscrewed to the upper stop anticlockwise, an integrated safety ring prevents that the screw can be completely unscrewed.

If a safety valve blow off, the system must be switched off immediately and investigate the cause of the error.

There are two possible reasons:

1. The safety valve is defective and blows off before the set pressure.

In this case the safety valve should be submitted immediately to the manufacturer for repair or replaced with a new one.

2. The safety valve opens properly, the problem is on the system.

A constant blowing of the safety valve is not permitted, the sealing seat of the valve can be damaged. The error on the system must be detected and repaired before further filling operations.

The safety valve may only be used if it is ensured that the maximum flowrate of the system does not exceed the blowoff rate of the safety valve.

The safety valve may only be used with the approved media.

Repair work on compressors must only be performed by trained personnel.

Dismantling of the safety valve

Ensure that on the safety valve is no pressure.

Loosen and remove the two M8 fixing bolts with a 6mm Allen key.

The safety valve can now be removed by turning and simultaneously pulling out of the socket.

Mounting

1. Clean the safety valve socket.

2. Oil the insert pin of the safety valve including the O-ring with 1 to 2 drops of oil.

3. Press the safety valve pin complete into the socket.

4. Fasten the safety valve with the two 8 mm allen screws into the socket

(Tightening torque: 10 Nm)

5. Screw the venting screw (hand wheel) anticlockwise to its upper limit.

6. Start the System (Compressor), check installation for leaks and proper function.

Manufacturer: Lenhardt & Wagner GmbH
An der Tuchbleiche 39
D-68623 Lampertheim – Hüttenfeld

Kontakt: E-Mail: service@lw-compressors.com
Web: www.lw-compressors.com
Tel.: +49 (0) 6256 – 85880 0
Fax: +49 (0) 6256 – 85880 14

Note:

*Use the safety valve only in a technically perfect condition, for its intended purpose, safety and danger awareness, in compliance with the operating instructions!
Especially disorders which could affect safety must be remedied immediately!*

Notes:

- The safety valve must be installed directly on the protected pressure vessel and / or the plant.
 - The safety valve must be installed in an upright position.
 - The flow area of the port must be greater than the valve opening.
 - Protect valve against splashes
-

Maintenance:

- The safety valve is periodically - in accordance with the currently valid Pressure Equipment Directives - to check on operation and reliability.
- Refill annually lubricating oil:
Oil filling position:
Hole on the spacer (see arrow, Figure 1)
- Oil level: Fill oil into the hole until oil comes out of the hole.

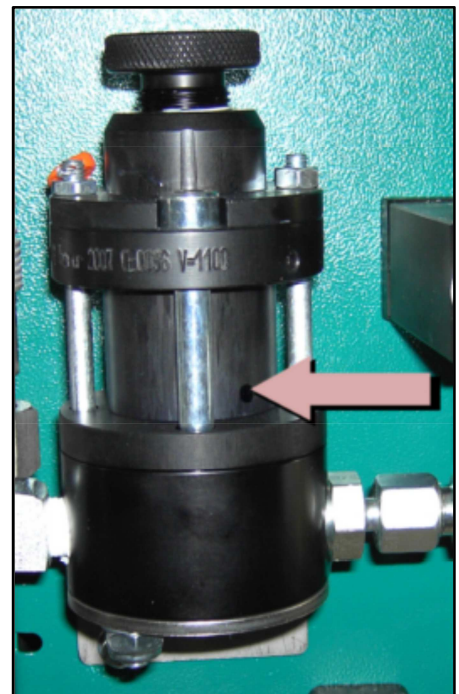

Figure 1: Position for oil refill

To be used lubricating oil for the safety valve: L&W Article Nr.: 008500 (content: 30 ml)
