



CHAPTER OVERVIEW

Operating Instructions

A

.....

B

Spare Parts Lists

C

Options (if equipped).....

D

Attachment

E

Manufacturer in terms of 97/23/EC

The full name and address of the manufacturer is:

Lenhardt & Wagner GmbH

An der Tuchbleiche 39

68623 Hüttenfeld / Germany

Phone: +49 (0) 62 56 - 85 88 0 - 0

Fax: +49 (0) 62 56 - 85 88 0 - 14

E-Mail: service@lw-compressors.com

Internet: www.lw-compressors.com





SERVICE INFORMATION / WARRANTY

Compressor information

Type designation

Serial number

Date of construction

Purchase information

Purchase date

First commissioned on

Warranty period

Dealer's stamp

Warranty

L&W will uphold warranty claims made during a period of 12 months from the invoice date.

If the compressor was purchased from an official L&W dealer, the date on the dealer's invoice is valid. Warranty claims can only be made on presentation of the original invoice.

Should verifiably defective parts have been delivered, we will decide to either replace the parts or repair them. The resulting transport and assembly costs will be invoiced.

No reduction of the purchase price or changes to the contract can be made. The parts for which a claim is being made should be kept safe by the purchaser and, when requested, sent to us at their cost. Replaced parts become the property of L&W. If maintenance work is carried out without our knowledge or permission by the purchaser or a third party, we are absolved from any liability for warranty claims. As a matter of principle, warranty claims can only be made by the initial purchaser.

Operating Instructions

Breathing Air Compressor

LW 230 E Compact / LW 280 E Compact / LW 320 E Compact

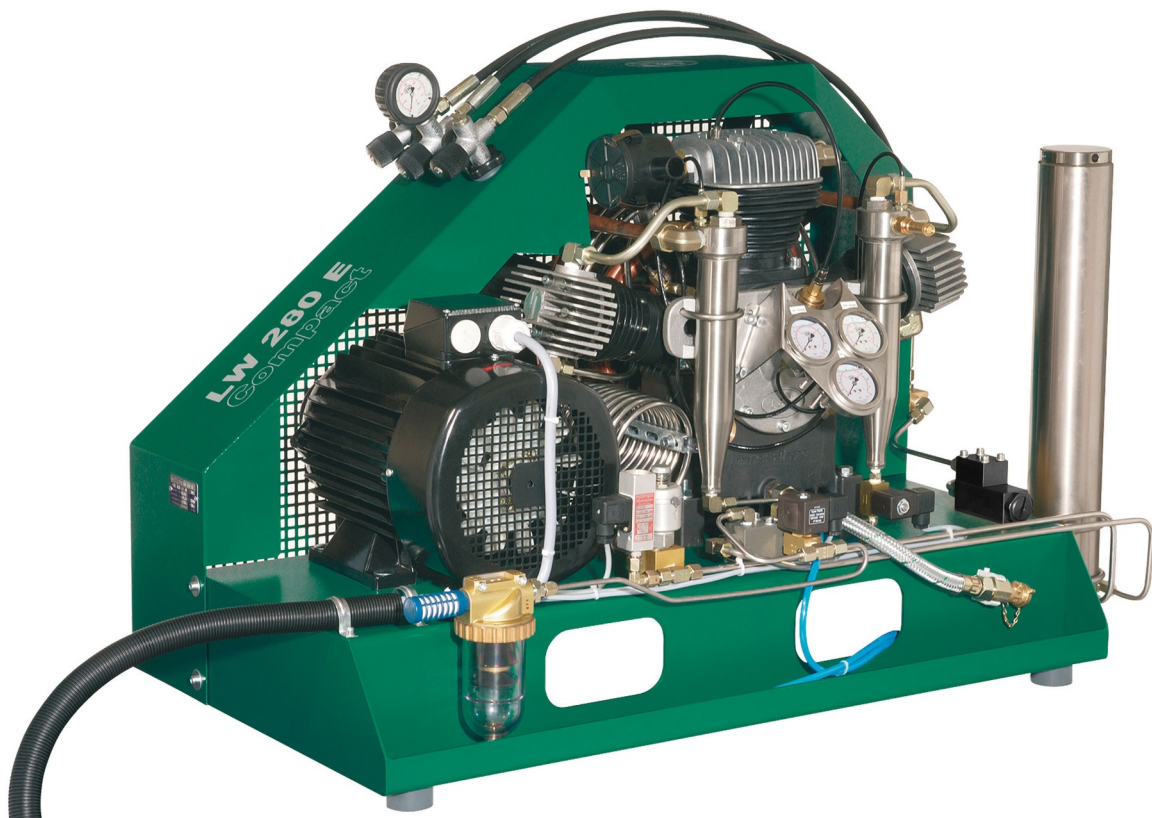



TABLE OF CONTENTS

General Information and Technical Data

General Information / Description of Warning Symbols	4
Scope of Delivery	5
Technical Data	6
Unit Assembly	7
Switchboard	8
Flow chart	9

Safety Precautions

Intended Use / Operators	11
Safety instructions on the unit	12
General Safety Precautions	13
Unit customised safety notices	14
Maintenance instructions	15
Transportation instructions / Safety regulations	16

Installation

Installation in closed rooms	18
Dimensions	19
Minimum distances	20
Ventilation	21
Electrical Installation	22 - 23

Operation

Important operation instructions	25
First commissioning	26 - 28
Daily commissioning	29
Filling procedure	30
Switch off the compressor	31

Remedying faults	32 - 36
-------------------------------	---------

Maintenance and Service

Service, Repair and Maintenance	38
Maintenance Lists / Maintenance Intervals	39 - 42
Service Kits	43
Check V-belt tension / Tension V-belt	44
Compressor lubrication / Check oil level	45
Oil change	46
Oil filter maintenance	47
Manual condensation dump system	48

A



TABLE OF CONTENTS

Maintenance and Service

Oil / Water separators 1st and 2nd stage - Maintenance	49
Filter housing / Filter cartridge	50
Filter cartridge change.....	51
Filter housing - Maintenance	52
Inlet filters / Inlet filter cartridge change	53
Cylinder heads and valves	54
Replace inlet and outlet valve 1st stage	55 - 56
Replace inlet and outlet valves 2nd and 3rd stage	57
Safety valves	58
Pressure maintaining / non return valve	59
Pressure gas vessel test	60
Maintenance records	61 - 66

Storage

Conservation / storage of the compressor	67
De-conservation, commissioning	67
Transportation instructions / Disposal	68

A



GENERAL INFORMATION

General Information

We strongly recommend reading this manual thoroughly prior to operation and follow all the safety precautions precisely. Damage resulting from any deviation from these instructions is excluded from warranty and liability for this product. Carry out other commissioning steps only if you have fully understood the following contents.

Before commissioning and using the unit, carry out all the essential preliminary work and measures concerning legal regulations and safety. These are described on the following pages of this operation manual.

A

Description of marks and warning signs

The following warning signs are used in this document to identify the corresponding warning notes which require particular attention by the user. The warning signs are defined as follows:



Caution

Indicates an imminently hazardous situation which, if not avoided, could result in serious injury, physical injury or death.



Warning

Indicates a potentially hazardous situation which, if not avoided, could result in physical injury or damage to the product or environment.



Note

Indicates additional information on how to use the unit.



DESCRIPTION

Scope of Delivery

Compressors are provided in different equipped versions.

A

Versions

Filling pressure versions:

- PN 225 bar
- PN 330 bar
- PN 225 / 330 bar

Specifications

- Painted steel frame and fan belt guard (RAL 6026)
- Hour counter
- Start/ Stop and emergency stop switch
- Manual condensate drain
- 1 x Filling hose c/w filling valve
- Motor protection switch (LW 230 Optional)
- Pressure maintaining and non return valve
- All pistons c/w steel piston rings
- Low pressure oil pump and filter
- Oil- / Water separators in stainless steel
- Safety valves after each stage
- 3 x concentric suction/pressure valves
- Filling pressure to your choice (200 or 300 bar)

Options

- Automatic condensate drain
- Automatic stop at final pressure
- Auto start system
- 200 and 300 bar parallel filling pressures
- Oil pressure gauge and intermediate pressure gauges
- Oil pressure monitoring c/w auto shut down
- Cylinder head temperature monitoring with auto shut down
- Puracon filter monitoring (Auto shut down also available)
- Phase monitoring c/w shut down at wrong direction of rotation
- Additional high pressure outlet
- Power cable and plug

DESCRIPTION

Technical Data



Technical Data	LW 230 E	LW 280 E	LW 320 E
Capacity [l/min]:	230	280	320
Max. Operating Pressure [bar]:	350	350	350
RPM [min ⁻¹]:	1080	1300	1450
Number of Pressure Stages:	3	3	3
Cylinder Bore 1st Stage [mm]:	Ø 95	Ø 95	Ø 95
Cylinder Bore 2nd Stage [mm]:	Ø 40	Ø 40	Ø 40
Cylinder Bore 3rd Stage [mm]:	Ø 18	Ø 18	Ø 18
Medium:	Compressed Air / Breathing Air		
Intake Pressure:	atmospheric		
Oil Pressure [bar]:	+0.6 to +4.0	+0.6 to +4.0	+0.6 to +4.0
Oil Capacity [l]:	1.8	1.8	1.8
Intake Temperature [°C]:	0 < +45	0 < +45	0 < +45
Ambient Temperature [°C]:	+5 < +45	+5 < +45	+5 < +45
Cooling Air Volume [m ³ /h]:	> 1650	> 2250	> 2250
Voltage:	400 V / 3 phase / 50 Hz		
Protection Class Drive Motor:	IP 54	IP 54	IP 54
Drive Power [kW]:	5.5	7.5	7.5
RPM Motor [min ⁻¹]:	2890	2890	2890
Start:	Star/Delta		
Noise level from a distance of 1 m [dB(A)]:	82	83	83
Dimensions W x D x H [mm]:	1200 x 600 x 900		
Weight [kg]:	approx. 195	approx. 195	approx. 195
Content Volume Filter housing [l]:	1.7	1.7	1.7

DESCRIPTION

Unit Assembly



Note

Following options for the shown compressor:

Auto shut down, automatic condensation drain, two additional filling hoses, intermediate pressure gauge, oil pressure display, remote control box.

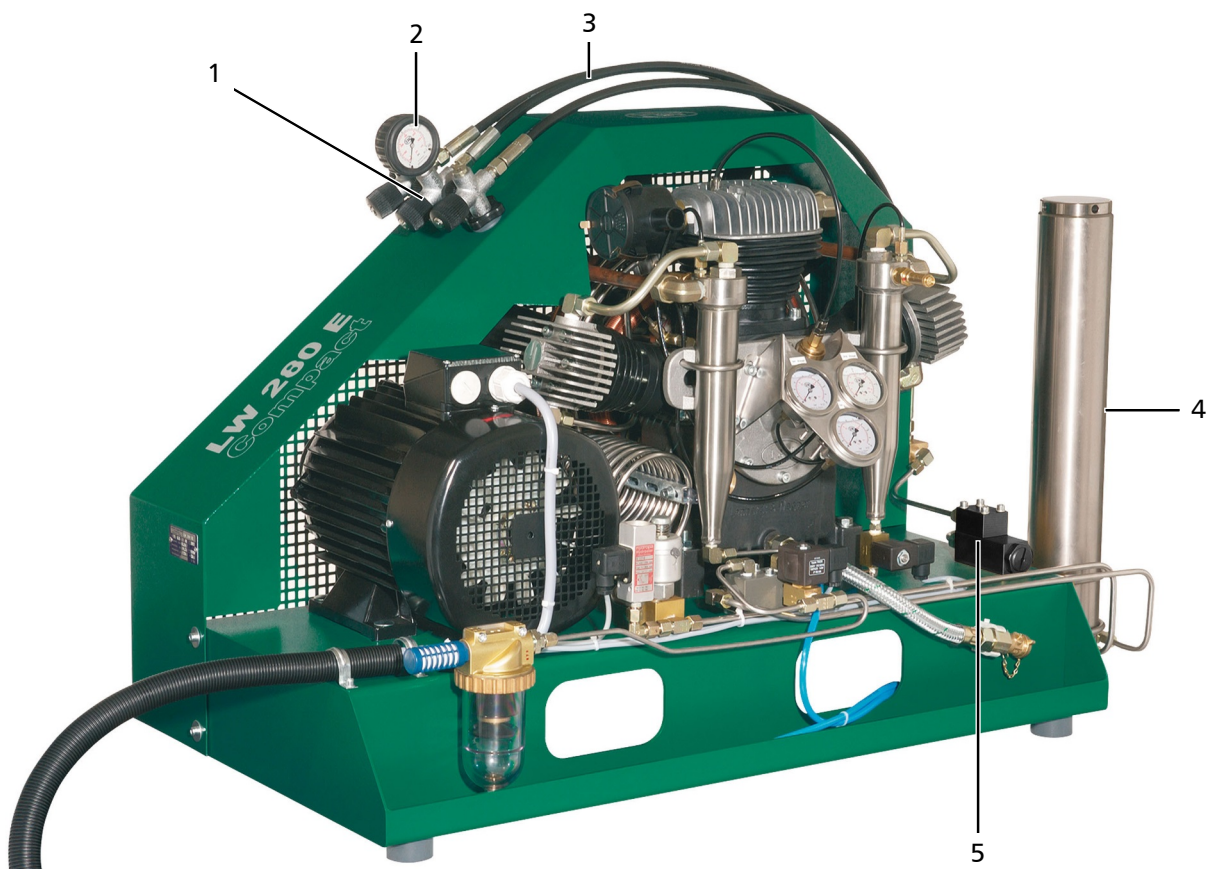

No.	Designation
1	Filling valve
2	Filling pressure gauge
3	Filling hose
4	Filter housing
5	Pressure maintaining / non return valve

DESCRIPTION

Switchboard

A

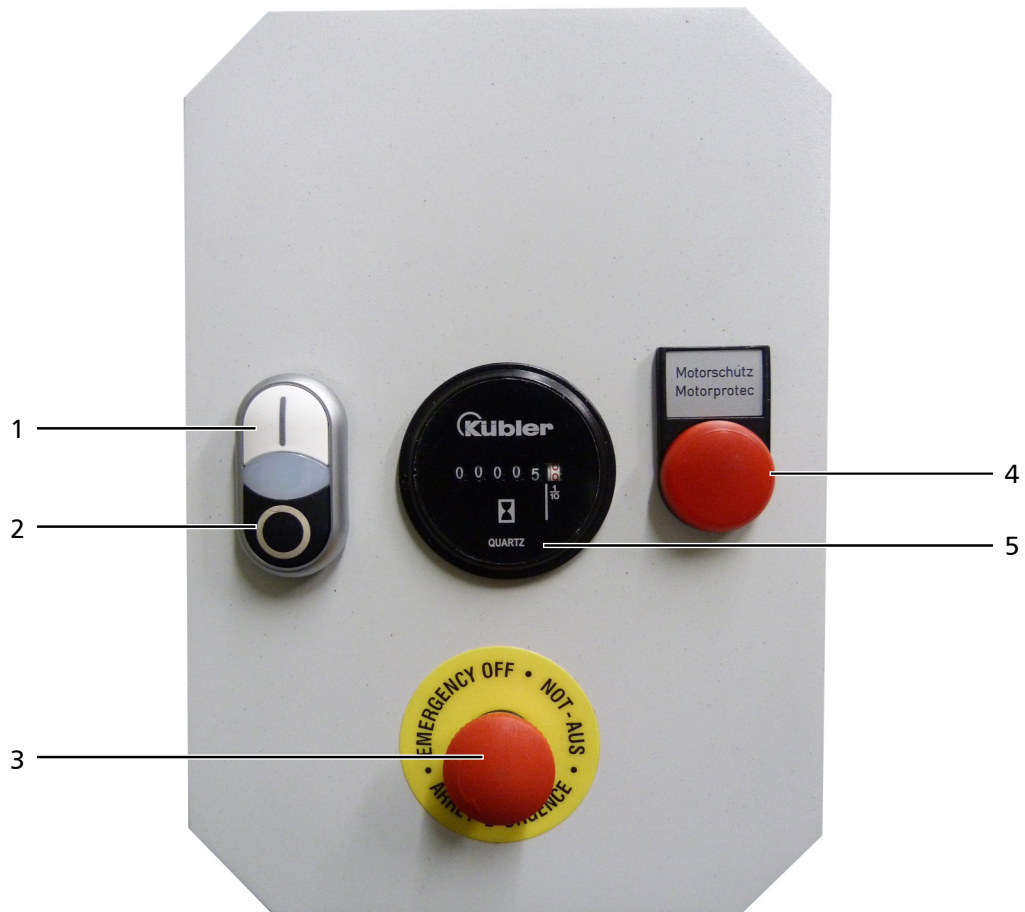

No.	Designation
1	ON button
2	OFF button
3	Emergency shut-off switch
4	Motor protection warning light
5	Hour counter

DESCRIPTION

Flow chart

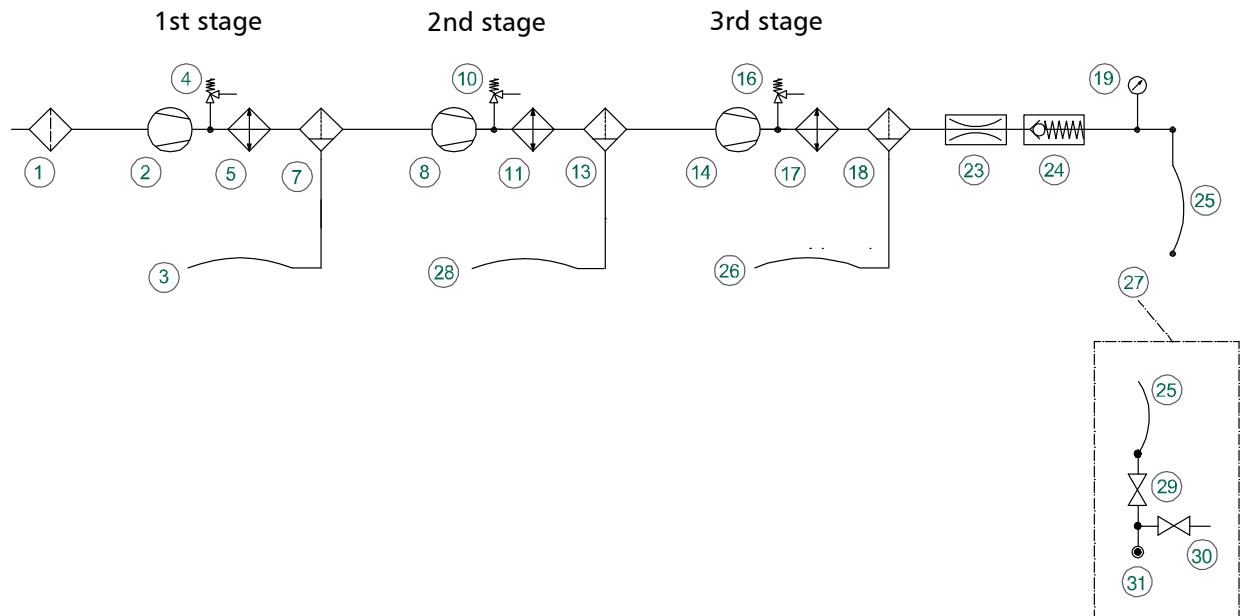

- | | |
|---|--|
| 1. Ansaugfilter / Air Intake Filter | 18. Öl-/Wasserabscheider / Oil-/Water Separator |
| 2. 1. Verdichterstufe / 1st Pressure Stage | 19. Druckmanometer (Fülldruck) / Pressure Gauge (Filling Pressure) |
| 3. Kondensatablaßschlauch / Condensate Release Hose | 23. Druckhalteventil / Pressure Maintaining Valve |
| 4. Sicherheitsventil 1. Stufe / Safety Valve 1st Stage | 24. Rückschlagventil / Non-Return Valve |
| 5. Wärmetauscher / Heat Exchanger | 25. Hochdruckschlauch / HP-Hose |
| 7. Öl-/Wasserabscheider / Oil-/Water Separator | 26. Kondensatablaßschlauch / Condensate drain hose |
| 8. 2. Verdichterstufe / 2nd Pressure Stage | 27. Füllventil / Filling valve |
| 10. Sicherheitsventil 2. Stufe / Safety Valve 2nd Stage | 28. Kondensatablaßschlauch / Condensate drain hose |
| 11. Wärmetauscher / Heat Exchanger | 29. Füllspindel / Filling spindle |
| 13. Öl-/Wasserabscheider / Oil-/Water Separator | 30. Entlüftungsspindel / Vent spindle |
| 14. 3. Verdichterstufe / 3rd Pressure Stage | 31. Flaschenanschluss / Tank Connector |
| 16. Sicherheitsventil 3. Stufe / Safety Valve 3rd Stage | |
| 17. Wärmetauscher / Heat Exchanger | |



A

SAFETY PRECAUTIONS



SAFETY PRECAUTIONS

Intended Use

Only use the unit in perfect condition for its intended purpose, safety and intended use and observe the operating instructions! In particular disorders that may affect safety have to be eliminated immediately!

Use the unit exclusively for the determined medium (see "Technical Data"). Any other use that is not specified is not authorized. The manufacturer/supplier shall not be liable for any damages resulting from such use. Such risk lies entirely with the user. Authorization for use is also under the condition that the instruction manual is complied with and inspection and maintenance requirements are enforced.

No change and modification to the unit can be made without the written agreement of the manufacturer. The manufacturer is not liable for damage to persons or property resulting from unauthorized modifications.

Operators

Target groups in these instructions;

Operators

Operators are persons who are authorized and briefed for the use of the compressor.

Qualified personnel

Qualified personnel are persons who are entitled to repair, service, modify and maintain the system.



Warning

Only trained personnel are permitted to work on the unit!



Warning

Work on the electrical equipment on / with the machine / unit may only be carried out by qualified electricians.

SAFETY PRECAUTIONS

Safety instructions on the unit

Importance of notes and warning signs that are affixed to the compressor according to the application or its equipment.

A



Warning
High voltage!



Note
Ensure correct direction of rotation!



SAFETY PRECAUTIONS

General Safety Precautions

- Read the Operating Instructions of this product carefully prior to use.
- Strictly follow the instructions. The user must fully understand and strictly observe the instructions. Use the product only for the purposes specified in the intended use section of this document.
- Do not dispose the operating instructions. Ensure that they are retained and appropriately used by the product user.
- Only trained and competent personnel are permitted to use this product.
- Comply with all local and national rules and regulations associated with this product.
- Only trained and competent personnel are permitted to inspect, repair and service the product.
- Only authentic L&W parts and accessories may be used for maintenance work. Otherwise, the proper functioning of the product may be impaired.
- Do not use faulty or incomplete products. Do not modify the product.
- Inform L&W in the event of any product or component fault or failure.
- The quality of the air supply must meet EN 12021 specifications for breathing air.
- Do not use the product in areas prone to explosion or in the presence of flammable gases. The product is not designed for these applications. An explosion might be the result if certain conditions apply.

A



SAFETY PRECAUTIONS

Unit customised safety notices

Organisational measures

- In addition to the instruction manual, observe and comply with universally valid legal and other obligatory regulations regarding accident prevention and environment protection.
- In addition to the instruction manual, provide supplementary instructions for supervision and monitoring duties taking into consideration exceptional factors e.g. with regard to organisation of work, production, personnel employed.
- Supervise personnel's work in accordance with the instruction manual, taking into account safety and danger factors.
- Observe all safety and danger notices on the compressor and check readability and completeness.

Safety instructions operation

- Take measures to ensure that the machine is only taken into operation under safe and functional conditions. Only operate the compressor if all protective and safety equipment, e.g. detachable protective equipment, are provided and in good working order.
- Check the compressor at least once per day for obvious damage and defects. Inform the responsible department / person immediately if anything is not as it should be (including operation performance). Shut down the machine immediately if necessary and lock it.
- In case of malfunction, stop the compressor immediately and lock it. Repair malfunctions immediately.
- If there is a failure in the electric energy supply, shut the machine / unit down immediately.
- Ensure safe and environmentally friendly disposal of consumables and old parts.
- The stipulated hearing protectors must be worn.
- Soundproofing equipment on the compressor has to be activated in safety function during operation.
- When handling with fats, oils and other chemical agents, observe the note for the product-related safety.

A



SAFETY PRECAUTIONS

Maintenance instructions

- Hoses have to be checked by the operator (pressure and visual inspection) at reasonable intervals, even if no safety-related defects have been detected.
- Immediately repair any damage. Escaping compressed air can cause injury.
- Depressurise system and pressure lines before beginning repair work.
- Pressurised air lines must be laid and mounted by qualified personnel. Connections must not be mixed up. Fittings, length and quality of the piping must correspond to requirements.
- Adjustment, maintenance and inspection activities and keep appointments, including information on replacement parts / equipment, prescribed in the operating instructions have to be respected.
- If the machine / equipment is completely off during maintenance and repair work, it must be protected against unexpected restart. Turn off main control device and remove the key and/or display a warning sign on the main switch.
- The machine and especially the connections and fittings should be cleaned from oil, fuel and maintenance products at the beginning of the maintenance / repair. Do not use aggressive cleaning agents. Use fibre-free cleaning cloths.
- Switch off compressor and clean with a slightly damp cloth. Remove dirt from cooling pipes by using a brush.
- After cleaning, examine all pipes for leaks, loose connections, chafing and damage. Immediately eliminate any faults.
- Always retighten any screw connections loosened for maintenance or repair work.
- If it is necessary to remove safety devices for maintenance and repair work, these must be replaced and checked immediately after completion of the maintenance or repair work.
- The electrical equipment of the compressor must be regularly checked. Defects, such as loose screw connections or burnt wires, must be immediately rectified by electrically skilled personnel.
- Only personnel with particular knowledge and experience with pneumatics may carry out work on pneumatic equipment.
- Only personnel with particular knowledge and experience in gas equipment may carry out work on gas equipment.

A



SAFETY PRECAUTIONS

Transportation instructions

- Parts which need to be dismantled for transport purposes must be carefully replaced and secured before taking into operation.
- The transport may only be carried out by trained personnel.
- For transportation, only use lifting devices and equipment with sufficient lifting power.
- Do not stand or work under suspended loads.
- Also separate from minor relocation machinery / system of any external energy supply. Before recommissioning, reconnect the machine to the mains according to regulations.
- When recommissioning, proceed according to the operating instructions..

Safety regulations

- Inspections according to legal and local obligatory regulations regarding accident prevention are carried out by the manufacturer or by authorised expert personnel. No guarantees whatsoever are valid for damage caused or favoured by the non-consideration of these directions for use.

A



A

INSTALLATION

INSTALLATION

Installation in closed rooms



Danger

No operation in explosion-hazard areas.
The unit is not approved for operation in areas prone to explosion.

For installation in closed rooms, observe the following:

- Install the unit horizontally and level. The floor must be vibration-free and capable of taking the load of the system weight.
- The compressor room must be clean, dry, dust free and as cool as possible. Avoid direct exposure to sunlight. If possible, install unit in such a manner that the compressor fan can intake fresh air from outside. Ensure adequate ventilation and exhaust air opening.
- When locating the compressor in rooms of less than 30 m³ space where natural ventilation is not ensured or other systems having high radiation are operating in the same room, measures must be taken to provide artificial ventilation.
- Intake air must be free from noxious gas e.g. smoke, solvent vapours, exhaust fumes etc.
- Observe the specified operating temperature (see "Technical Data")!



Hinweis

- Intake air must be free from noxious gas e.g. smoke, solvent vapours and exhaust fumes. We recommend not to use the intake air inside the compressor housing. An intake hose would be recommendable!

Approximate value - Diameter of intake hose depending on the length of the intake hose

Pos.	Length of Intake Hose [m]	Diameter of Intake Hose [mm]
1	≤ 03	Ø 30
2	≤ 10	Ø 80
3	≤ 15	Ø 100
4	≤ 20	Ø 120

INSTALLATION

Dimensions

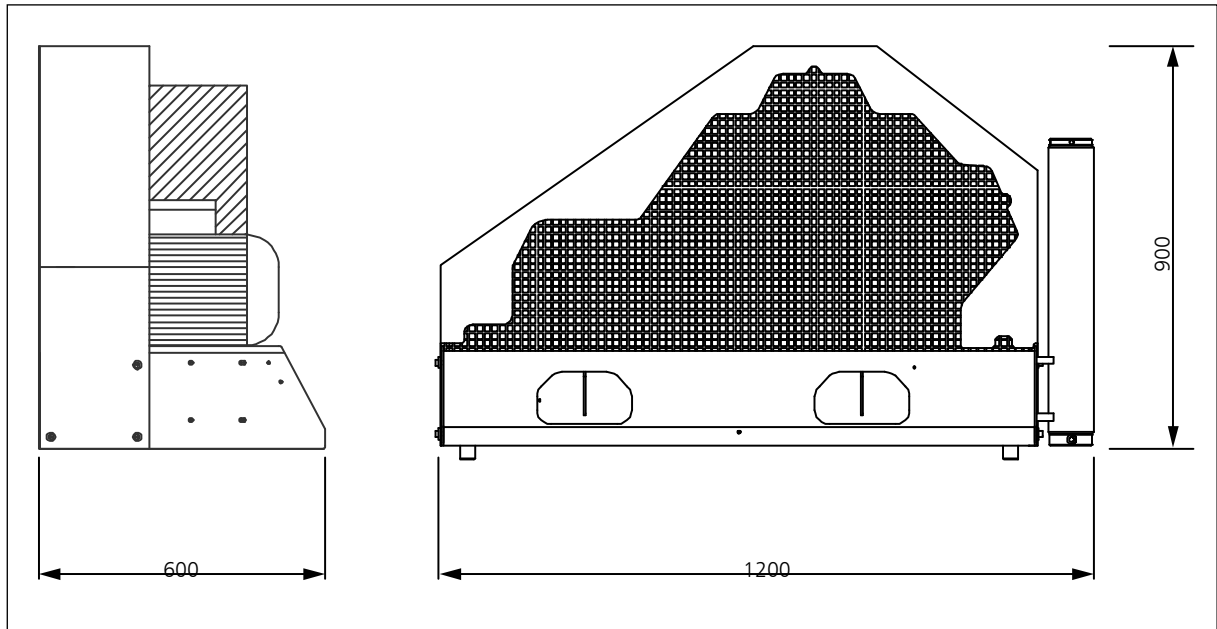

A

Fig. Dimensions

INSTALLATION

Minimum distances



Note

Minimum distances must be adhered!

- Make sure that the compressor always has a sufficient amount of fresh air available.
- To prevent serious damage, ensure that the cooling air flow can flow freely.
- The following minimum distances must be adhered:
Front side min. 1500 mm, sides min. 500 mm, rear side min. 500 mm.
Avoid anything in this area which can restrict the cooling air flow.

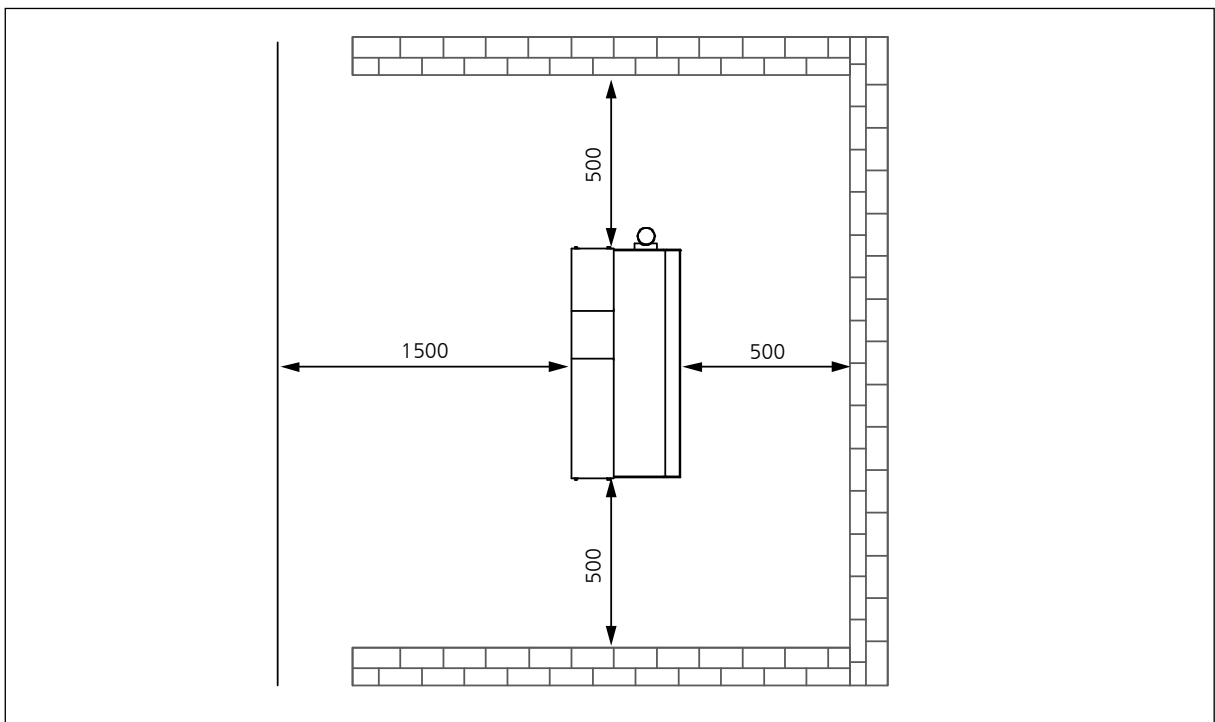

Fig. Minimum distances

INSTALLATION

Ventilation

- Make sure that the compressor always has a sufficient amount of fresh air available for cooling.
- To prevent serious damage, ensure that the cooling air flow can flow freely.
- The necessary cooling air flow can be calculated by using the following formula:
 $300 \times \text{drive power [kW]} = \text{required cooling air flow [m}^3/\text{h]}$
 Example 11kW motor: $300 \times 11\text{kW} = 3300 \text{ m}^3/\text{h} = \text{required cooling air flow.}$
- The fan capacity for fresh air and warm air must meet at least the required cooling air flow.
 The fans must have the same capacity.

A

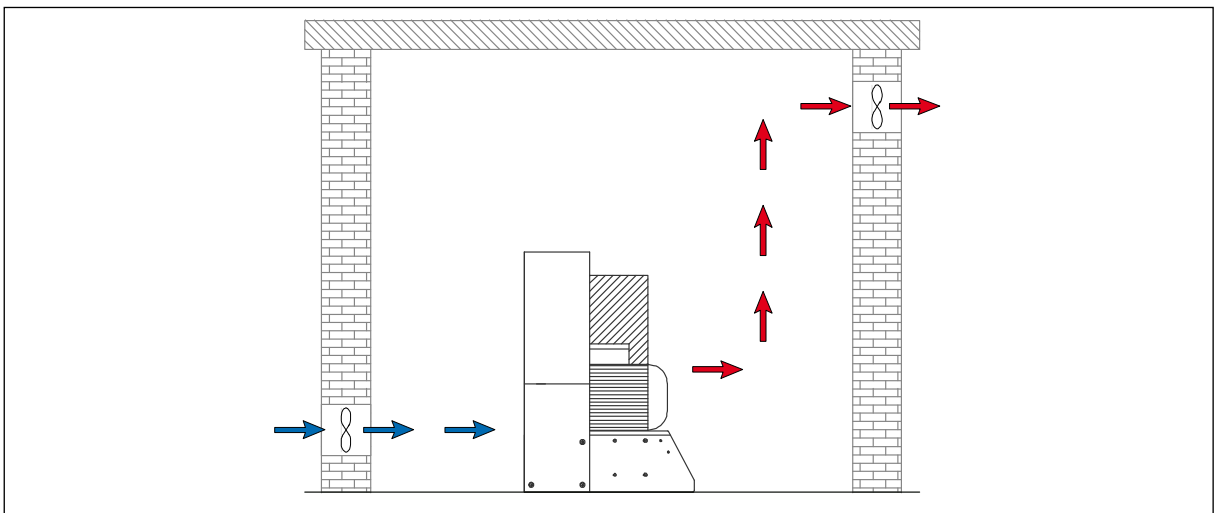

Fig. Ventilation through facade

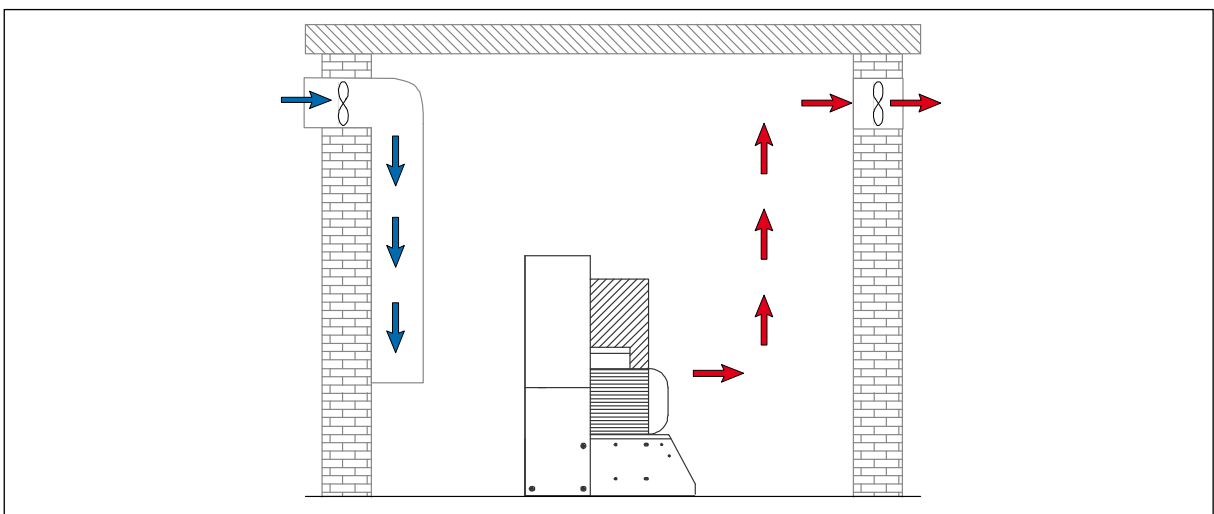

Fig. Ventilation via ventilation stack

INSTALLATION

Electrical Installation



Warning

Work on the electrical equipment on / with the machine / unit may only be carried out by qualified electricians.

For installation of electrical equipment, observe the following:

- If control devices are delivered by the factory, refer to the appropriate wiring diagram.
- Ensure correct installation of protective conductors.
- Check conformity of motor and control device tension and frequency with those of the electric network (see name plate on the compressor).
- The fusing should be done in accordance with the valid regulations of the responsible electricity supply company.
- When connecting the unit to the electrical supply, check the compressor direction of rotation (see chapter "Maintenance" -> Check turning direction).
- Fuse the motor correctly (see table; use slow-blow fuses).

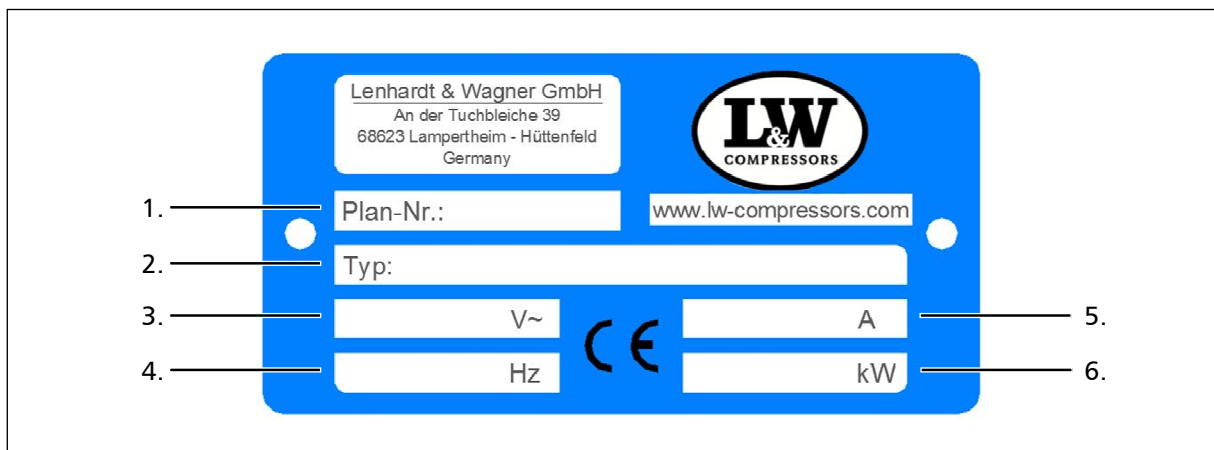

Fig. Compressor name plate

No.	Designation
1.	Circuit diagram number
2.	Compressor type
3.	Power supply
4.	Frequency
5.	Motor current consumption
6.	Nominal motor power

INSTALLATION

Electrical Installation

The standard compressor version is prepared for the connection to three phases (brown, black, grey), neutral conductor (blue) and protective earth conductor (green/yellow).

Fig. - Connection to the switch box

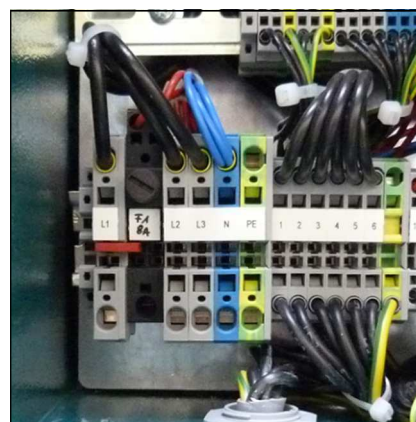

A

Recommended fuses for 360 - 500 V operating voltage

Nominal motor power		Fusing start A		Connection in mm ²	
[kw]	[A]	Direct	Star/Delta	Contactor supply	Motor S/D
2.2	5	10	-	1.5	1.5
4	8.5	20	-	2.5	1.5
5.5	11.3	25	20	2.5	1.5
7.5	15.2	30	25	2.5	1.5
11	21.7	-	35	4	2.5
15	29.9	-	35	6	4
18.5	36	-	50	6	4
22	41	-	50	10	4
30	55	-	63	10	6

Recommended fuses for 220 - 240 V operating voltage

Nominal motor power		Fusing start A		Connection in mm ²	
[kw]	[A]	Direct	Star/Delta	Contactor supply	Motor S/D
2.2	8.7	20	-	1.5	1.5
4	14.8	25	-	2.5	1.5
5.5	19.6	35	25	4	2.5
7.5	26.4	50	35	6	4
11	38	-	50	6	4
15	51	-	63	10	4
18.5	63	-	80	16	6
22	71	-	80	16	6
30	96	-	125	25	10



A

OPERATION



OPERATION

Important operation instructions



Note

Ensure that all persons handling the compressor are familiar with function and operation of the unit.



Wear hearing protection

When working on a running machine, always wear hearing protection.

A

FIRST COMMISSIONING

A

Prior to first commissioning, observe the following:

Necessary steps are described on the next page.

- Ensure that cooling air can flow freely.
- Check compressor oil level by the oil sight glass (see next page).
- Check all connections and retighten if necessary.
- Check if the filter cartridge is in place (see "Service and Maintenance").
- Check the V-belt tension (see next page).
- Check if all filling valves are closed. Open one filling valve and hold tight manually!

Start the compressor

1. Start the compressor by pushing the ON button.
2. Check turning direction - see the rotary direction arrow on the housing of the electric motor (see next pages). If the turning direction is wrong, immediately stop the compressor by pushing the OFF button and contact an authorised electrician.



Warning

Wrong impeller rotation direction!

Immediately after switching the compressor on, check the rotation direction. Depending on the place of installation, the phase sequence can influence the rotation direction.

3. Check oil pressure (if oil pressure gauge is installed).
4. Run the compressor for about 2 minutes.
5. Close the open filling valve carefully.
6. Run the compressor up to maximum pressure and check if the safety valve opens at the adjusted set pressure. (The set pressure value is engraved on the knurled screw of the safety valve.) If this function can not be ensured, the unit must be immediately taken out of service. -> Change safety valve!
7. Check the compressor unit for leaks (little smoke emission and release noises from the inlet filter housing can be ignored).
8. Now check the condensate drain valves:
 - Fix the black condensate hoses
 - Open manual condensate drain valves
 - If correct, air escapes
9. Stop the compressor by pushing the OFF button.
10. Open all filling valves carefully to vent.

FIRST COMMISSIONING

Check oil level



Warning

Check oil level daily. Never start the compressor with a too low oil level. Risk of accidental loss, destruction or deterioration.

Check the oil level before each operation of the unit by using the oil dipstick.

Oil level check as follows:

- Unscrew oil dipstick
- Wipe off oil residues
- Insert the oil dipstick back into its tube and screw it until stop
- Unscrew oil dipstick again

The oil level should be between the notch and the end of the oil dipstick. If there is no oil between the notch and the end of the oil dipstick, refill immediately new full synthetic compressor oil.



Oil dipstick

Check V-belt tension

The V-belts could lose tension during transportation. Please check the V-belt tension before starting the compressor.

Tension V-belts

To tighten V-belt tension, loosen 4 mounting nuts of the drive motor. Use the tensioning screw to move the electric motor until the V-belt tension is sufficient. Then, tighten mounting nuts and check V-belt tension.

We recommend using a V-belt tension gauge.

Correct V-belt tension

Do not tension V-belts too tight. This damages bearings of compressor and motor. The V-belts should only be tensioned until there is no noise caused by slipping during start.

Settings

Motor Type	Initial Installation	Operation after running in
Electric motors 50Hz	500 N	400 N
Electric motors 60Hz	400 N	300 N

FIRST COMMISSIONING

Check turning direction



Warning

Wrong impeller rotation direction!

Immediately after switching the compressor on, check rotation direction. Depending on the place of installation, the phase sequence can influence the rotation direction.

Before starting the compressor for the first time, check rotation direction (see the rotary direction arrow on the housing of the electric motor).

If the direction of rotation is wrong, the guide pistons of the 2nd and 3rd stages can not be sufficiently lubricated, with the consequence that the pistons will be damaged. Furthermore, cooling air flow will not be sufficient.

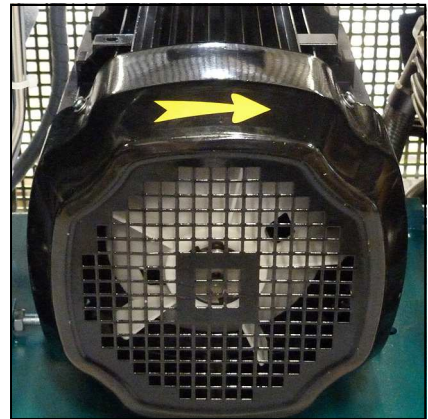

Rotation direction arrow

A



DAILY COMMISSIONING

Prior to daily operation observe the following:

- Ensure cooling air can flow freely.
- Check compressor oil level by the oil sight glass.
- Check if filter cartridge is in place / observe filter cartridge life!
- Ensure toxic-free, pure intake air.

A

OPERATION

Filling procedure

**Caution! Fill only cylinders which:**

- are marked with the test mark and the test stamp of the expert.
- have been hydrostatic tested (check last test date).
- are rated for the final pressure.
- are free from humidity.

**Note**

The unit must be stopped manually when final pressure is reached. No serial auto shut down. The unit must also be started manually.

**Caution**

Vent condensate drain valves every 15-30 minutes manually.

1. Close all filling valves.
2. Connect the closed compressed air cylinders.
3. Open cylinder valves.
4. Start the compressor by pushing the ON button.
5. When filling pressure gauge increases, open filling valves slowly.
6. Fill the compressed air cylinders to the desired pressure; subsequently close the filling valves slowly.
7. Switch off the compressor.
8. Close and vent all filling valves.
9. Disconnect all compressed air cylinders from filling valves.
10. Open condensate drain valves manually.



OPERATION

Switch off the compressor

The compressor unit is not equipped as standard with an auto shut down. The unit must always be stopped manually when final pressure is reached.

During filling process, the system can be shut down at any time by pushing the red button (OFF) or the emergency stop (only in case of emergency!).



Note

After switching off, open condensate drain valves manually to vent the unit.

A



A

REMEDYING FAULTS

REMEDYING FAULTS

A

Final pressure can not be reached

Cause of fault	Remedy
Connections leaky	Retighten or clean/replace if necessary
Final pressure safety valve leaky	Replace
Pipes / heat exchanger broken	Replace
Condensate drain valves leaky	Unscrew valves, check sealing surfaces, clean, replace if necessary
Final pressure switch stop unit	Verify settings, replace if necessary
Piston of pneumatic condensate valve sticks	Clean pneumatic condensate valve and restore function, check/replace o-rings, replace valve completely if necessary

Strong compressor vibration

Cause of fault	Remedy
V-belt tension too loose	Tension V-belt
Drive motor / Compressor unit loosely	Retighten mounting screws
Anti vibration mounts used up	Replace
Ground not levelled	Ensure a solid and level ground

Air supply too low

Cause of fault	Remedy
Inlet and outlet valves contaminated / defective	Clean, replace if necessary
Cylinder(s), piston(s) or piston ring(s) used up	Replace
V-belt slips	Tension V-belt
See chapter "Final pressure can not be reached"	See chapter "Final pressure can not be reached"

REMEDYING FAULTS

Compressor overheated

Cause of fault	Remedy
Inlet filter cartridge contaminated	Replace
Ambient temperature too high	Improve room ventilation /
Cooling air inlet and outlet insufficient	Observe minimum distances (see Installation Instructions)
Air intake hose too long	Reduce length of the air intake hose
Air intake hose diameter too small	Use a larger diameter
Wrong compressor rotation direction	Ensure correct phase rotation,
Inlet and outlet valves contaminated / defective	Clean, replace if necessary

Safety valve leaks

Cause of fault	Remedy
Inlet and outlet valves of the following pressure stage defective	Clean, replace if necessary
Sinter filter of the following water separator blocked	Replace
Safety valve leaky	Replace

Oil taste in the air

Cause of fault	Remedy
Mole carbon filter cartridge saturated	Replace
Compressor oil unsuitable	Use prescribed oil quality
Filter cartridge unsuitable	Use prescribed filter type
Cylinder(s), piston(s) or piston ring(s) defective	Replace

REMEDYING FAULTS

Automatic condensate drain defective

Cause of fault	Remedy
Solenoid coils defective	Replace
Cable / supply cable defective	Repair, replace if necessary
Timer / relais defective	Replace
Sinter filter of pneumatic condensate valve blocked	Replace
Piston of pneumatic condensate valve sticks	Clean pneumatic condensate valve and restore function, check/replace o-rings, replace valve complete if necessary

Condensate drain starts before reaching final pressure

Cause of fault	Remedy
Pressure stages are not as prescribed, control pressure of pneumatic condensate valve too low	Check corresponding inlet and outlet valve, replace if necessary.
Piston sealing of pneumatic condensate valve contaminated / used up	Clean, replace if necessary
Timer / relais settings not correct	Adjust as prescribed
Timer / relais defective	Replace

Compressor stops before final pressure

Cause of fault	Remedy
Final pressure switch settings not correct	Correct settings
Opening pressure of the pressure maintaining valve too high	Correct settings
Fuse / circuit breaker has tripped Valid only for E models	Check fusing of the power supply / observe regulations
Emergency stop switch has tripped	Unlock emergency stop switch, close compressor housing door correctly



REMEDYING FAULTS

A

Filter life not sufficient

Cause of fault	Remedy
Pressure maintaining valve settings not correct	Adjust as prescribed
Filter cartridge unsuitable	Replace by a prescribed filter cartridge type
Filter cartridge too old	Observe expiration date
Filter cartridge packaging incorrect / damaged / already opened. Filter cartridge already partly saturated before change	Store filter cartridges properly, dispose defective cartridges
Operating temperature too high	Ensure sufficient ventilation
Cylinder(s), piston(s) or piston ring(s) defective	Replace

Oil consumption too high

Cause of fault	Remedy
Cylinder(s), piston(s) or piston ring(s) defective	Replace
Compressor oil unsuitable	Use prescribed oil quality
Operating temperature too high	Observe prescribed operating temperatures
Oil leak at the compressor block	Tighten corresponding mounting screws, if necessary replace corresponding paper sealing / o-ring / shaft seal



A

MAINTENANCE AND SERVICE

MAINTENANCE AND SERVICE

Service, Repair and Maintenance

Carry out service and maintenance work exclusively when the compressor is stopped and depressurised. The unit should be leak-checked regularly. Leaks can be preferably localised by using a leak detector spray (if necessary, brush pipes with soapy water).

We recommend that only authorised L&W service technicians carry out service work on the bearing of the compressor (crankshaft and connecting rods).

We urgently recommend that all maintenance, repair and installation work must only be carried out by trained personnel. This is necessary because all maintenance work can not be explained exactly and detailed in this manual.

Only use authentic spare parts for service work.



Danger

Components under pressure, such as hose ends, can quickly come loose when manipulated and can cause potentially fatal injuries due to the pressure surge. Any work on system parts may only be performed in a pressure-compensated state.



Warning

The use of accessories that have not been tested can lead to death or serious injury or damage to the unit. Only use authentic spare parts for service work.



Warning

Carry out maintenance or service work when the unit is switched off and protected against unexpected restart.



Warning

Risk of burns!

Carry out maintenance or service work when the unit has cooled down.



MAINTENANCE AND SERVICE

Daily before taking unit into operation

Maintenance work	Type	Quantity	Order No.
Check oil level	-	-	000001
Check condition of all filling hoses	-	-	-
Check filter cartridge lifetime	-	-	-
Operate unit to final pressure and check function of final pressure switch	-	-	-

At 25 operation hours

Maintenance work	Type	Quantity	Order No.
Oil change	-	1.8	000001

Every 3 months or as required

Maintenance work	Type	Quantity	Order No.
Check automatic condensate drain, open manual condensate taps	-	-	-
Check/Retorque all connections and bolts	-	-	-

A

MAINTENANCE AND SERVICE

Annually

Maintenance work	Type	Quantity	Order No.
Oil change, if less than 1000 operating hours	-	1.8	000001
Check V-belt tension and condition	LW 230 EC (50Hz)	2	003694
	LW 230 EC (60Hz)	2	000148
	LW 280 EC (50Hz)	2	001685
	LW 280 EC (60Hz)	2	003694
	LW 320 EC (50Hz)	2	001685
	LW 320 EC (60Hz)	2	001685
Check opening pressure of final safety valve	-	-	-
Clean coolers	-	-	-
Clean all oil/water separators, if less than 500 operating hours	-	-	-
Service intake filter (depends on condition - if less than 500 operating hours)	-	-	-
Clean oil filter element, if less than 1000 operating hours	-	-	-
Check all connections for leakage	-	-	-

Every 500 operating hours

Maintenance work	Type	Quantity	Order No.
Change intake filter *	-	1	000170
Check pressure maintaining/non-return valve	-	-	-
Check V-belt tension and condition	see above	see above	see above



* Note

Article is part of our 1000h and 2000h service kits.

MAINTENANCE AND SERVICE

Every 1000 operating hours (latest in 5 years)

A

Maintenance work	Type	Quantity	Order No.
Replace sintered metal filter element of water separators	1st and 2nd stage	2	002123
Replace o-rings of water separators	1st and 2nd stage	2	001255
Replace o-ring of oil separator	-	1	001294
Replace silencer	-	1	000178
Replace sintered metal filter of oil separators	-	1	000184
Replace sintered metal filter of pneumatic condensate valve	-	1	000188
Replace o-rings of the final filter housing	-	2	001287
Replace back-up rings of the final filter housing	-	2	001285
Replace sintered metal filter of oil filter	-	1	000184
Replace o-ring of oil filter	-	1	000435
Oil change	-	1.8	000001



Note

All stated quantities are parts of our 1000h and 2000h service kits. You can find an overview on page Service Kits.



MAINTENANCE AND SERVICE

Every 2000 operating hours (latest in 10 years)

Maintenance work	Type	Quantity	Order No.
Replace all inlet and outlet valves incl. Gaskets	1st stage	1	002093
	2nd stage	1	000542
	3rd stage	1	000543
	Upper gasket 1st	1	000257
	Lower gasket 1st	1	000258



Note

All stated quantities are parts of our 2000h service kits. You can find an overview on page Service Kits.

MAINTENANCE AND SERVICE

Service Kits

The service kits contain parts for maintenance according to the factory requirements.

The use of the service kits ensures that all required parts are ordered and replaced and gives assurance that all parts are included in the order. Depending on the model and interval, the service kits include parts such as O-Rings, Sinter Filter, Inlet Filter, Silencers, In-&Outlet Valve, Valve Seals and Compressor oil.



Service Kits

A

Service Kits LW 230 E / 280 E / 320 E Compact (manual condensate drain)

Compressor	Operating Hours	Order No.
LW 230 E Compact	1000 h	011061
LW 230 E Compact	2000 h	011062
LW 280 E Compact	1000 h	011061
LW 280 E Compact	2000 h	011062
LW 320 E Compact	1000 h	011061
LW 320 E Compact	2000 h	011062

Service Kits LW 230 E / 280 E / 320 E Compact (automatic condensate drain)

Compressor	Operating Hours	Order No.
LW 230 E Compact	1000 h	004970
LW 230 E Compact	2000 h	003920
LW 280 E Compact	1000 h	004970
LW 280 E Compact	2000 h	003920
LW 320 E Compact	1000 h	004970
LW 320 E Compact	2000 h	003920



Note

V-belts are not included in our 1000h and 2000h service kits.



MAINTENANCE AND SERVICE

Check V-belt tension

The V-belts could lose tension during transportation. Please check the V-belt tension before starting the compressor.

A

Tension V-belts

To tighten V-belt tension, loosen 4 mounting nuts of the drive motor. Use the tensioning screw to move the electric motor until the V-belt tension is sufficient. Then, tighten mounting nuts and check V-belt tension.

We recommend using a V-belt tension gauge.

Correct V-belt tension

Do not tension V-belts too tight. This damages bearings of compressor and motor. The V-belts should only be tensioned until there is no noise caused by slipping during start.

Settings

Motor Type	Initial Installation	Operation after running in
Electric motors 50Hz	500 N	400 N
Electric motors 60Hz	400 N	300 N

Check oil level



Warning

Check oil level daily. Never start the compressor with a too low oil level. Risk of accidental loss, destruction or deterioration.

Check the oil level before each operation of the unit by using the oil dipstick.

Oil level check as follows:

- Unscrew oil dipstick
- Wipe off oil residues
- Insert the oil dipstick back into its tube and screw it until stop
- Unscrew oil dipstick again

The oil level should be between the notch and the end of the oil dipstick. If there is no oil between the notch and the end of the oil dipstick, refill immediately new full synthetic compressor oil.



Oil dipstick

Oil change



Note

We recommend oil change at least once a year - depending on total operating hours.

A

Oil change as follows:

- Run compressor warm for approx. 2 min.
- Switch off and vent compressor.
- Place a suitable oil drain tray under the drain hose.
- Open carefully oil drain valve and drain oil completely.
- Close oil drain valve.
- Loosen oil fill port with an appropriate adjustable wrench (AF 0-40 mm) and unscrew manually.
- Fill oil by using a funnel.
- Check oil level. The oil level should be between the middle and upper end of the oil sight glass.
- Screw oil fill port manually in and tighten with the adjustable wrench.

The oil change is now completed.

Maintenance intervals

- First oil change after 25 operating hours (total hours).
- All further changes after each 1,000 operating hours.

Oil and oil capacity

Approx. 1800 ml synthetic compressor oil is necessary for one oil change. Only use synthetic compressor oil which is recommended as suitable from L&W.

Oil filter maintenance



Caution

Oil filter housing is filled with oil. Take all necessary protection measures.



Note

Clean all parts thoroughly before assembly.

Oil filter maintenance as follows:

- Loosen pipe connections
- Loosen mounting screws (Fig. 1) and remove oil filter
- Loosen mounting screws of the filter cover (Fig. 2).
- Change o-ring, previously grease new o-ring (Fig. 3)
- Loosen mounting nuts and remove filter washer (Fig. 4)
- Change sinter filter (Fig. 4).
- Place filter washer and washer (Fig. 5) and tighten nut.
- Place filter cover, fix and tighten mounting screws of the filter cover (Fig. 2).
- Screw and tighten mounting screws of the oil filter (Fig. 1).
- Connect pipe connections and tighten.

The oil filter maintenance is now completed.

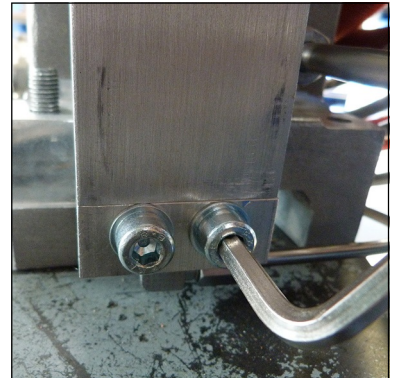

Fig. 1 - Loosen mounting screws

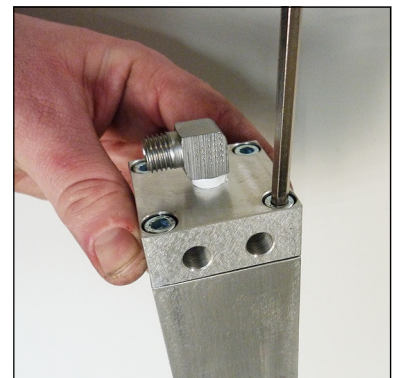

Fig. 2 - Loosen mounting screws of the filter cover

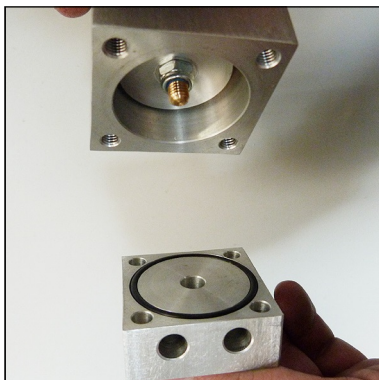

Fig. 3 - Change o-ring

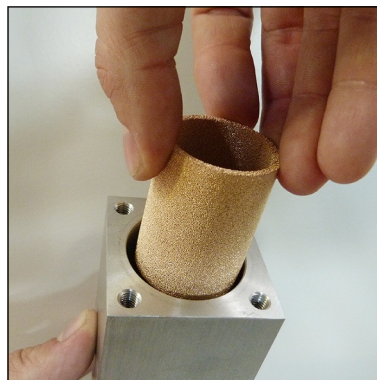

Fig. 4 - Change sinter filter



Fig. 5 - Place filter washer and washer

MAINTENANCE AND SERVICE

Manual condensation dump system



Note

The collected condensate can contain oil and has to be disposed according to regulations.

Oil- / water separators

The compressor comes as standard with an automatic condensation dump system. Drain condensate separators every 15 minutes.

To release the complete condensate through the black plastic hoses we recommend using a 20 l container at least.

The drain noise can be kept to a minimum by using a silencer.

Manual drain



Warning

Open valve spindle max. 1.5 turns.
The pressure in the housing can shoot out the valve spindles at high speed.

To drain manually, open the condensate drain valves of the 1st and the 2nd stage of the oil / water separators and the condensate drain valve of the filter housing (Fig. 2).

Open valve spindle max. 1.5 turns anti-clockwise. The condensate will be drained.

Then close valve spindle clockwise.

Maintenance intervals

We recommend to clean oil and water separators every 500 operating hours or at least once a year, to check for corrosion damage and to replace o-rings if necessary.

All oil / water separators have an integrated sinter filter which has to be replaced every 1,000 operating hours.

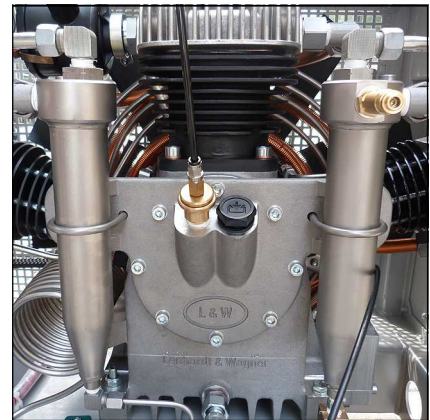

Fig. 1 Oil / water separators 1st and 2nd stage with automatic condensate drain system

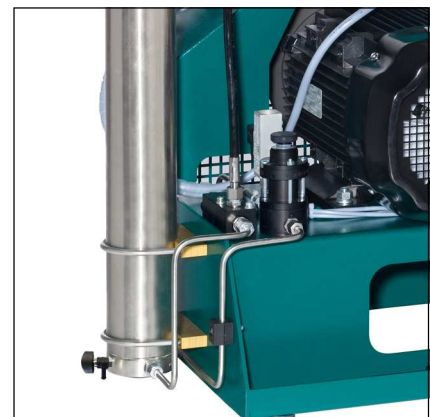

Fig. 2 - Condensate drain valve of the filter housing



Fig. 3 - Condensate drain valve

A

Oil / Water separators 1st and 2nd stage - Maintenance



Note

Clean all parts thoroughly before assembly.

Maintain oil / water separators 1st and 2nd stage as follows:

- Loosen pipe connections (Fig. 1)
- Loosen screw connection at the water separator (sinter filter holder)
- Remove sinter filter holder (Fig. 2).
- Change sinter filter (Fig. 3), screw-in new sinter filter by using a suitable screwdriver.
- Change o-ring, previously grease new o-ring (Fig. 4)
- Place sinter filter holder into the water separator and tighten
- Connect pipe connections and tighten.

The oil / water separator maintenance is now completed.

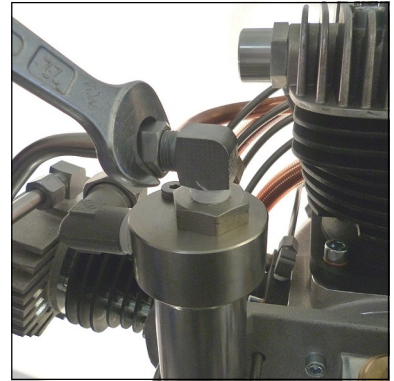

Fig. 1 - Loosen pipe connections

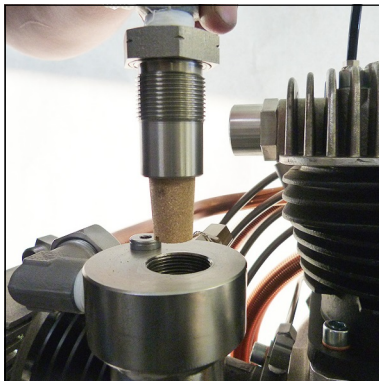

Fig. 2 - Remove sinter filter holder



Fig. 3 - Change sinter filter



Fig. 4 - Change o-ring

MAINTENANCE AND SERVICE

Filter housing

The mole carbon filter housing is installed on the right hand side of the compressor housing.

Inside the filter housing a jet blows air on to the housing wall. Condensation water and oil are led by centrifugal force to the bottom of the housing. Air flows through the mole carbon filter cartridge, which purifies the air from residual moisture and odours.

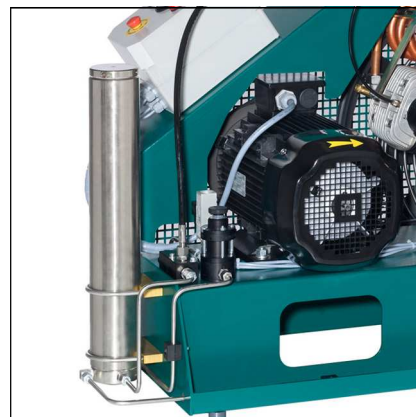

Filter housing

Filter cartridge

The high-pressure compressor is equipped with an integrated breathing air purification system. Air is compressed up to 330 bar, dried and odour- and tasteless purified. Oil residues are bounded. The breathing air filter cartridge consists of a molecular sieve and activated-carbon filter.

Cartridge capacity: approx. 1.7 l

All breathing air filter cartridges are factory vacuum sealed.

We recommend unpacking the filter cartridges just before installation. Filter cartridges which are exposed too long could be saturated with moisture and become unusable.

P/N	Filtering	Models
000002 000003	DIN EN 12021 (Breathing Air)	For models with 1.7 ltr Filter housings For models with 2.3 ltr Filter housings
001459	DIN EN 12021 (Breathing Air) incl. CO/CO2	For models with 1.7 ltr Filter housings For models with 2.3 ltr Filter housings
001466 001467	Only oil / odour removal (<0,1mg/m ³)	For models with 1.7 ltr Filter housings For models with 2.3 ltr Filter housings
001460 001462	Only drying (<15mg/m ³)	For models with 1.7 ltr Filter housings For models with 2.3 ltr Filter housings
001468	CNG filter (drying and oil removal)	For models with 2.3 ltr Filter housings

Maintenance intervals

Filter cartridges should be changed at the following intervals, at +20°C or more often, depending on humidity and ambient temperature:

- 72 hours for LW 230 E Compact
- 54 hours for LW 280 E Compact
- 46 hours for LW 320 E Compact

MAINTENANCE AND SERVICE

Filter cartridge change

Filter cartridge change as follows:

- Run the compressor up to a pressure of 100 bar.
- Stop compressor.
- Open filling valve.
- Unscrew filter housing cover by using the special filter tool (Fig. 1).
- Place the T-piece end of the filter tool in the recess of the filter cartridge (Fig. 2).
- Unscrew the filter cartridge anti-clockwise and pull the cartridge out of the housing (Fig. 3).
- Open the packing of the new filter cartridge and place it with the filter tool in the filter housing.
- Screw the new filter cartridge hand tight in by using the filter tool.
- Screw the cover of the filter housing first manually in.
- After it has been completely screwed in, turn cover anticlockwise for 90°. This avoids tightening of the cover due to vibration..

The filter cartridge change is now completed.



Note

Ensure that the old filter cartridge is disposed correctly at an approved waste point.



Fig. 1 - Unscrew the filter housing cover.



Fig. 2 - Place the T-piece end of the filter key in the top of the filter cartridge.



Fig. 3 - Pull the cartridge out of the housing.

A

Filter housing - maintenance



Note

Clean all parts thoroughly before assembly.

Filter housing maintenance as follows:

- Open Filter Cover (Fig. 1).
- Change o-ring and back-up ring, previously grease both (Fig. 2).
- Grease filter cover thread and close.

Dismount filter housing

- Loosen pipe connections and nuts (Fig. 3).
- Remove filter housing.
- Dismount filter housing base.
- Change o-ring and back-up ring, previously grease both (Fig. 4).
- Screw filter base tight in.

Mount filter housing

- Connect pipe connections and tighten.
- Adjust holding clamp and tighten nuts.

The filter housing maintenance is now completed.



Fig. 1 - Open Filter cover



Fig. 2 - Change o-ring and back-up rings

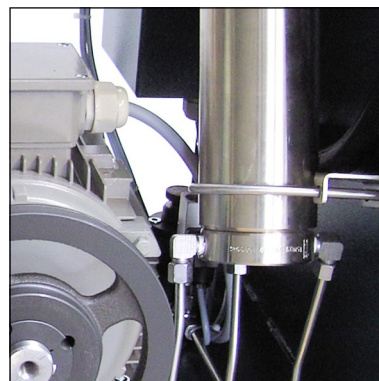

Fig. 3 - Loosen pipe connections and nuts



Fig. 4 - Change o-ring and back-up rings

MAINTENANCE AND SERVICE

Inlet filters



Note

Dirty filters make intaking air difficult and reduce delivery capacity. Risk of compressor overheating.

A micro filter cartridge is used as an air inlet filter. Check air inlet filter regularly or replace it. Defective air inlet filters should be immediately replaced with a corresponding filter.

Maintenance intervals

We recommend that the filter cartridge should be replaced every 500 working hours (depending on pollution grade).

Inlet filter cartridge change

Inlet filter cartridge change as follows:

- Loosen cover by pushing the three clips apart.
- Remove inlet filter cartridge and replace it by a new one.
- Refit cover and snap the three clips until a loud 'click' can be heard.

The inlet filter cartridge change is now completed.

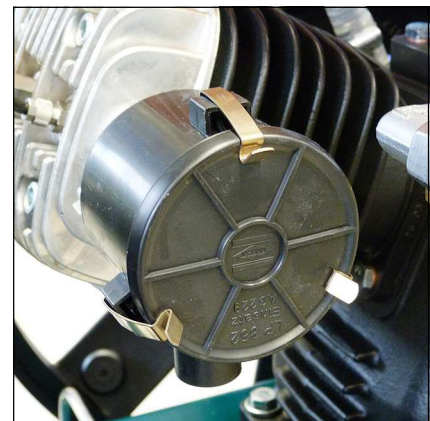

Air filters

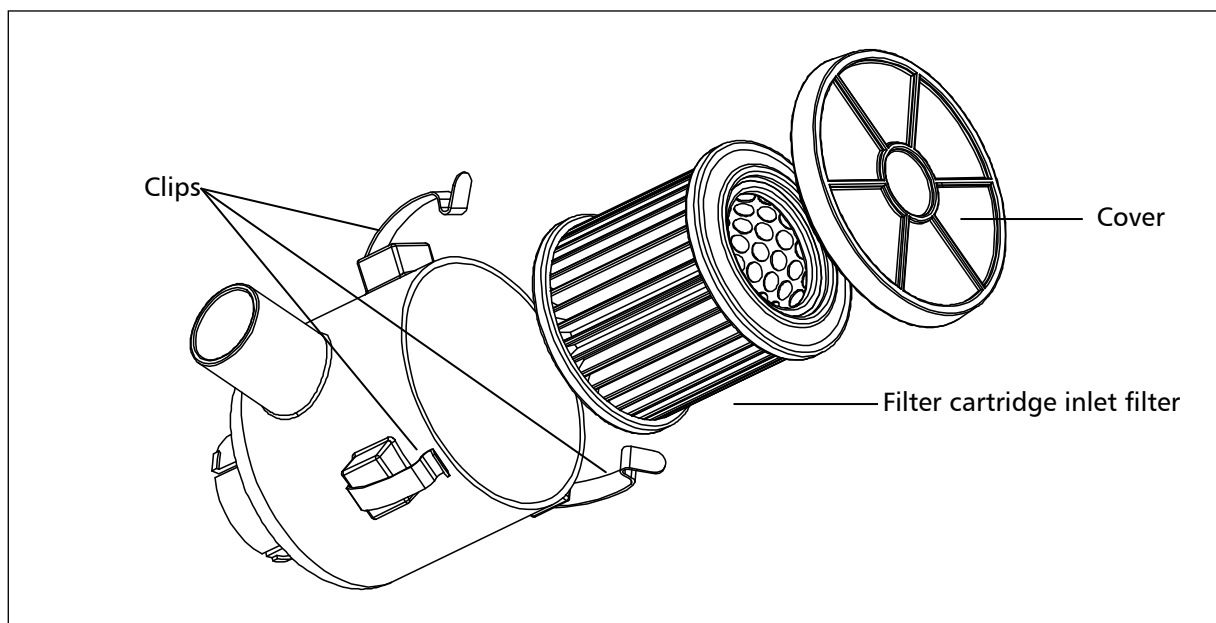

Filter cartridge inlet filter

MAINTENANCE AND SERVICE

Cylinder heads and valves

Inlet and outlet valves of the specific compressor stages are located between valve head and cylinder. Outlet valves open while piston upstroke or compression stroke, inlet valves open while downstroke.

Valves are subject to normal wear and tear and have to be replaced at certain intervals (depending on specific operating conditions). Dismount valve heads to change valves. The three valves are combined inlet and outlet valves. The first stage is a plate valve. The stages two and three are made of a spring operated piston which acts inside a bronze cylinder.



Inlet and outlet valve incl. gaskets of the 3rd stage

Maintenance intervals

All valves should be replaced after 2000 working hours due to normal wear and tear. To replace valves the cylinder heads have to be removed. There are no special tools required to replace these valves.

Available special tools

Special tools are not necessary for dismounting inlet and outlet valves but make work easier.

Order number: 006847



Special tool

Replace inlet and outlet valve 1st stage



Note

The figures of the parts can differ due to the different stages.

Replace the inlet and outlet valve 1st stage as follows:

Remove Inlet / Outlet Valve

- Loosen pipe connections
- Loosen screw connections of the crankcase ventilation hose (Fig. 1)
- Remove hose
- Loosen valve head screws
- Remove valve head
- Pull out inlet and outlet valve (Fig. 2)
- CAUTION: Observe that the lower copper valve ring is also pulled out. It can still stick inside the cylinder (Fig. 3).
- Check valve head if defective

Install Inlet / Outlet Valve - see following page

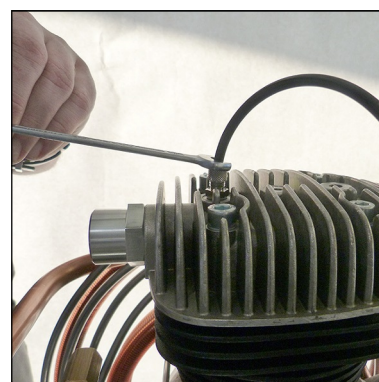

Fig. 1 - Loosen valve head screws

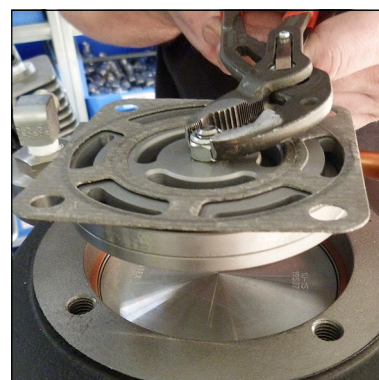

Fig. 2 - Pull out inlet and outlet valve

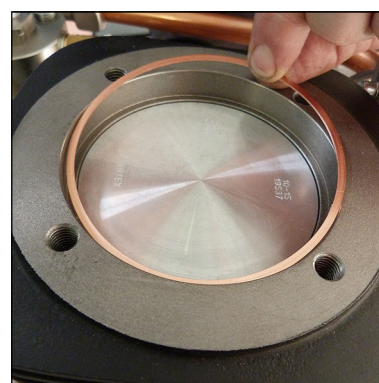

Fig. 3 - Copper valve ring

Replace inlet and outlet valve 1st stage - continued from previous page



Warning

The exact alignment of upper and lower valve gasket is very important. Inlet and outlet channels have to be exactly centred.

Install Inlet / Outlet Valve

- Grease new lower valve gasket and place into the cylinder.
CAUTION: Ensure the correct mounting position of the copper valve ring (position the burr-free side in direction of the cylinder).
- Place the new inlet and outlet valve on the cylinder and align upper valve gasket (paper gasket) (Fig. 4).
CAUTION: Do not turn the inlet and outlet valve inside the cylinder! The paper gasket could cover inlet channels!
- Refit the valve head and tighten the valve head screws crosswise. (Fig. 5)
- Torques: 1st stage 40 Nm
- Fit crankcase ventilation hose and tighten screw connection
- Connect pipe connections and tighten (Fig. 6).

Inlet and outlet valves change 1st stage is now completed.

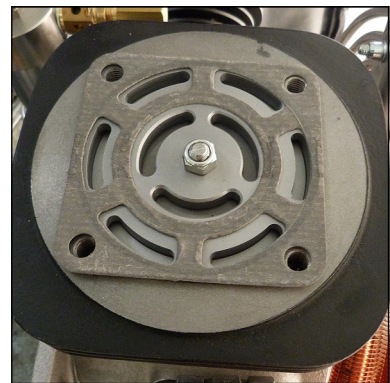

Fig. 4 - Place and align upper valve gasket

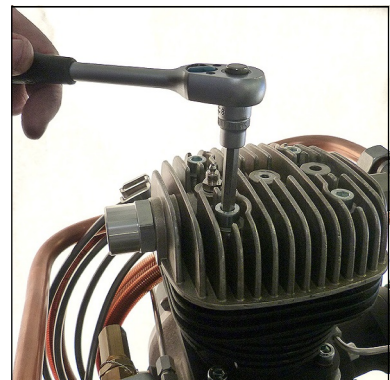

Fig. 5 - Screw valve head screws in



Fig. 6 - Connect pipe connections and tighten

MAINTENANCE AND SERVICE

Replace inlet and outlet valves 2nd and 3rd stage



Note

The figures of the parts can differ due to the different stages.

Inlet and outlet valves change as follows:

- Loosen pipe connections (Fig. 1).
- Loosen valve head screws (Fig. 2).
- Remove lower valve gasket (Fig. 3).
- Dismount inlet and outlet valve (Fig. 4).
Observe that the upper valve gasket is also pulled out. It can still stick inside the cylinder head.
- Check valve head if defective (check centre pin)
- Mount valve gasket on inlet and outlet valve
CAUTION: Ensure correct mounting position of the upper valve gasket (Fig. 5).
- Insert new inlet and outlet valve into valve head
CAUTION: Observe correct position between valve centre hole and valve head centre pin.
- Place lower valve gasket
- Place valve head with the new inlet and outlet valve. Tighten valve head screws crosswise (tightening torque 35 Nm).
- Connect pipe connections and tighten.

The inlet and outlet valves change is now completed.

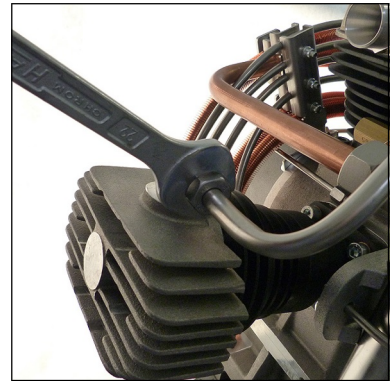

Fig. 1 - Loosen pipe connections

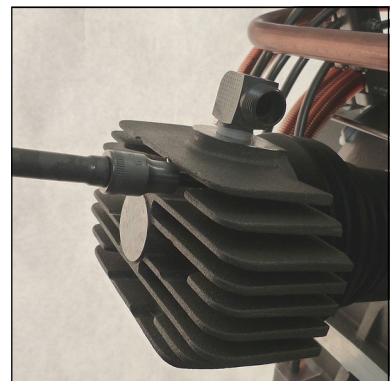

Fig. 2 - Loosen valve head screws

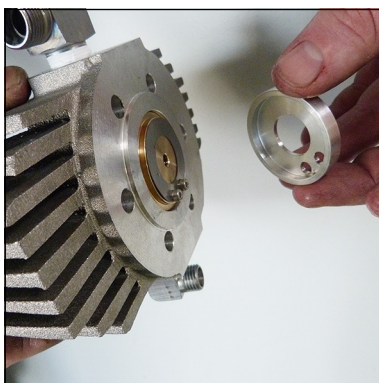

Fig. 3 - Remove lower valve gasket

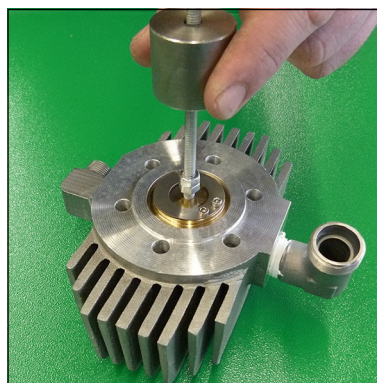

Fig. 4 - Remove inlet and outlet valve



Fig. 5 - Ensure correct mounting position of the upper valve gasket

MAINTENANCE AND SERVICE

Safety valves

Every pressure stage is equipped with a separate over pressure safety valve. Safety Valves avoid a non permissible high pressure at the specific pressure stages and limit maximum operation pressure of the compressor.

Safety valves are adjusted to:

- 1st Stage: 8 bar
- 2nd Stage: 60 bar
- 3rd Stage: max. final pressure

The adjusted blow-off pressure [bar] of the safety valves is indicated on their housings.

All safety valves are factory sealed with special L&W safety seals to avoid manipulation of the limit value settings.

Safety valves with removed seals have to be immediately checked for the prescribed settings and replaced if necessary.

The safety valve of the final stage is furthermore equipped with a knurled screw to be activated once.

Turning the knurled screw clockwise could vent the valve completely and therefore the final filter housing.

During normal operation conditions, the knurled screw has to be turned anti-clockwise up to the upper stop. An integrated circlip avoids complete unscrewing.

If a safety valve blows off, it indicates problems with either inlet or outlet valve of the following stage.



Note

Replace defective safety valves immediately!

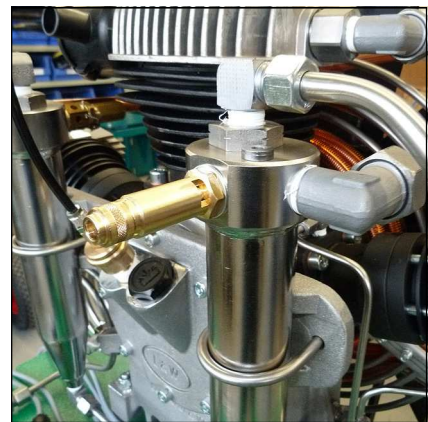

Safety valve 1st stage

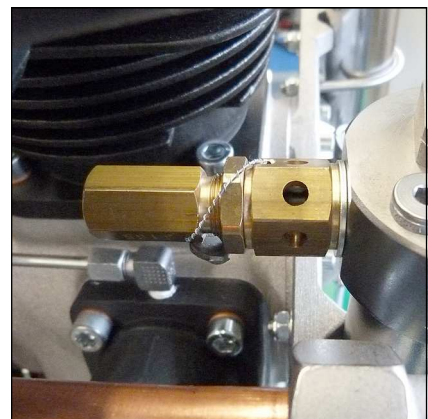

Safety valve 2nd stage



Safety valve 3rd stage

A

Pressure maintaining / non return valve

**Note**

If the adjusted opening pressure of the pressure maintaining valve is higher than the final pressure of the compressor, the final pressure safety valve blows off before pressure maintaining valve opens (final pressure = 0 bar). When valve settings are not clear (e.g. after disassembly / repair), start the adjustment with a low basic setting (turn adjusting screw approx. 3 times in).

A pressure maintaining / non return valve is installed after the filter housing. It maintains a pressure of at least 150 bar inside the filter housing - this optimises filter efficiency.

Pressure maintaining valve

The pressure maintaining valve drains a large part of the water content of the compressed air mechanically by ensuring the minimum outlet pressure. This guarantees optimal drying and purification of the breathing air.

After starting the compressor, the pressure inside the final filter housing constantly increases. The pressure maintaining valve prevents the compressed air from blowing off (final pressure gauge = 0 bar).

When the adjusted opening pressure is reached (150 and 180 bar), the purified compressed air flows via pressure maintaining and non return valve to the filling valve.

The value of the opening pressure of the pressure maintaining valve can be read at the final pressure gauge. When opening pressure is reached, the pressure gauge value increases within a few seconds.



Pressure maintaining/non-return valve



MAINTENANCE AND SERVICE

Test of pressure equipment

According to the German Industrial Safety Ordinance 2015, pressure equipment is subject to regular inspection.

Subject: pressure equipment with a product permissible operating pressure [bar] x content volume [litres] from 200 up to 1000.

Example: Filter housing 1.7 l

Maximum operating pressure: 350 bar

Content volume: 1.7 litres

$350 \text{ bar} \times 1.7 \text{ litres} = 595$

595 is smaller than 1000 -> result: Test is applicable!!

Example: Filter housing 2.3 l

Maximum operating pressure: 350 bar

Content volume: 2.3 litres

$350 \text{ bar} \times 2.3 \text{ litres} = 805$

805 is smaller than 1000 -> result: Test is applicable!!

Pressure equipment from 200 up to 1000 have to be tested as follows:

1. Examination after 5 years by a qualified person or authorized organisations:

Visual inspection, inside and outside.

2 Examination after 10 years by a qualified person or authorized organisations:

Visual inspection, inside and outside.

In addition, a water pressure test is carried out at 1.5 times of the permissible vessel operating pressure.



A

MAINTENANCE RECORDS



MAINTENANCE RECORDS

Introduction form for the Operator

A

No.	Surname, Name	Date	Place	Signature	Instructor

By adding themselves to this list, the person that signs it confirms having been given a yearly introduction/instruction about the function and operation of the compressor unit. Furthermore, they have be informed about the relevant safety rules and regulations (TRG, DGRL, BetrSichV, GSG, GSGV).



MAINTENANCE RECORDS

Top up oil, oil change

Date	Operating hours	Oil quantity [l]	Name

A



MAINTENANCE RECORDS

Cartridge change

A

Date	Operating hours	Difference	Name



MAINTENANCE RECORDS

Maintenance work

A

Description	Date, signature



MAINTENANCE RECORDS

Replaced Parts

A

Designation	Part number	Date, signature



STORAGE

Conservation / storage of the compressor

If the compressor unit is not to be used for an extended period of time, we recommend to carry out the following work before storage time:

- Run the compressor at 200 bar filling pressure for approximately ten minutes (control the flow with the filling valve to maintain constant pressure).
- Replace compressor oil, open filling valve(s) and run compressor for a few minutes.
- Stop compressor and open drain valves (depending on the compressor type, this may happen automatically). Remove top cap of final filter housing: clean throat, grease o-ring. and throat with a food grade grease or silicone grease. Close filter housing.
- Remove intake filter cartridge and undo intake pipes on all valve heads.
- Start compressor unit. Spray a few drops of compressor oil into intake connectors.
- Stop compressor unit and insert intake filter cartridge. Bring intake pipes back in position and fix connections and nuts. Close filling- and drain valves.
- Store the compressor in a cool dry place free from dust and contamination. A dust cover is recommended as long as condensation can be avoided.
- If compressor unit should be stored for a period of more than one year, an oil change is strongly recommended before it's been re-used.
- Fuel driven units only: fill up fuel tank to top level to avoid corrosion.

De-conservation, commissioning

After the compressor has been stored, the following steps are to be taken:

- If compressor hasn't been used for longer than 12 months, we strongly recommend an oil change before any use.
- Replace intake filter cartridge and check oil level.
- Clean compressor unit, check for foreign objects. Check condition and tension of V-belts, replace if necessary. Check condition of filling hoses, replace if necessary.
- Secure hoses against whipping and open filling valves and run compressor for approximately 10 minutes.
- Check condition of final filter cartridge, replace if necessary.
- Close filling valves and run compressor up to final pressure.
- Check safety valve relief pressure of final stage and/or pressure switch setting.
- Check all connections and pipe work for leaks.

Once all above steps are completed, compressor unit is now ready for use.

STORAGE

Transportation instructions

- Parts which need to be dismantled for transport purposes must be carefully replaced and secured before taking into operation.
- The transport may only be carried out by trained personnel.
- For transportation, only use lifting devices and equipment with sufficient lifting power.
- Do not stand or work under suspended loads.
- Also separate from minor relocation machinery / system of any external energy supply. Before recommissioning, reconnect the machine to the mains according to regulations.
- When recommissioning, proceed according to the operating instructions..

Disposal

The product must be disposed in accordance with national waste disposal regulations and by an appropriate waste disposal company.

Electric and electronic components

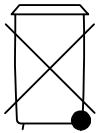

EU-wide regulations for the disposal of electric and electronic appliances which have been defined in the EU Directive 2002/96/EC and in national laws are effective from August 2005 and apply to this device.

Common household appliances can be disposed by using special collecting and recycling facilities. However, as this device has not been registered for household usage, it must not be disposed of through these means.

The device can be returned to L&W. Please do not hesitate to contact us if you have any further questions on this issue.



**ERSATZTEILLISTEN / SPARE PARTS LISTS
DETAILANSICHTEN / DETAILED VIEWS**

C



Inhaltsverzeichnis

Schalttafel - Control Board.....	1
Kompressorblock - Compressor Block.....	3
Öl-Wasserabscheider 1.+2. Stufe - Oil-Water Separator 1st+2nd Stage	7
Filtergehäuse 1,7l - Filter Housing 1.7ltr	11
Ansaugfilter - Air Intake Filter	13
Sicherheitsventil - Safety Valve	15
Pneum. Kondensatventil - Pneum. Condensate Valve.....	17
Druckhalteventil - Pressure Maintaining Valve.....	19
Ölfilter - Oil Filter.....	21
Ölpumpe - Oil Pump.....	23
Kolben 1. Stufe - Piston 1st Stage.....	25
Kolben 2. Stufe - Piston 2nd Stage.....	27
Kolben 3. Stufe - Piston 3rd Stage	29
Kurbelwelle - Crankshaft.....	31
Kühlrohre - Cooling Pipes.....	33
Lüfterrad - Fan Wheel.....	35
Motor	37
Saug+Druckventil 1. Stufe - In+Outlet Valve 1st stage	39
Saug+Druckventile 2.+3. Stufe - In+Outlet Valves 2nd+3rd Stage	40
Ölablassschlauch - Oil Drainage Tube	41
Verteilerleiste mit Füllschlauch - Distributor Block with Filling Hose	43
Kreuzventil - Cross Design Valve	45



ERSATZTEILLISTE / SPARE PART LIST

Baugruppe: Schalttafel / Control Board

Best.-Nr. / Order No.	Benennung	Description
002089	Betriebsstunderzähler 230V	Hour Counter 230V
002942	Start/Stop Schaltelement	Start / Stop Button
003121	Not-Halt Schalter	Emergency switch
004701	Warnlampe	Warning lamp
006859	Schildträger	Label holder
006925	Einlegeschild	Label

C

DETAILANSICHT / DETAILED VIEW

Baugruppe: Schalttafel / Control Board

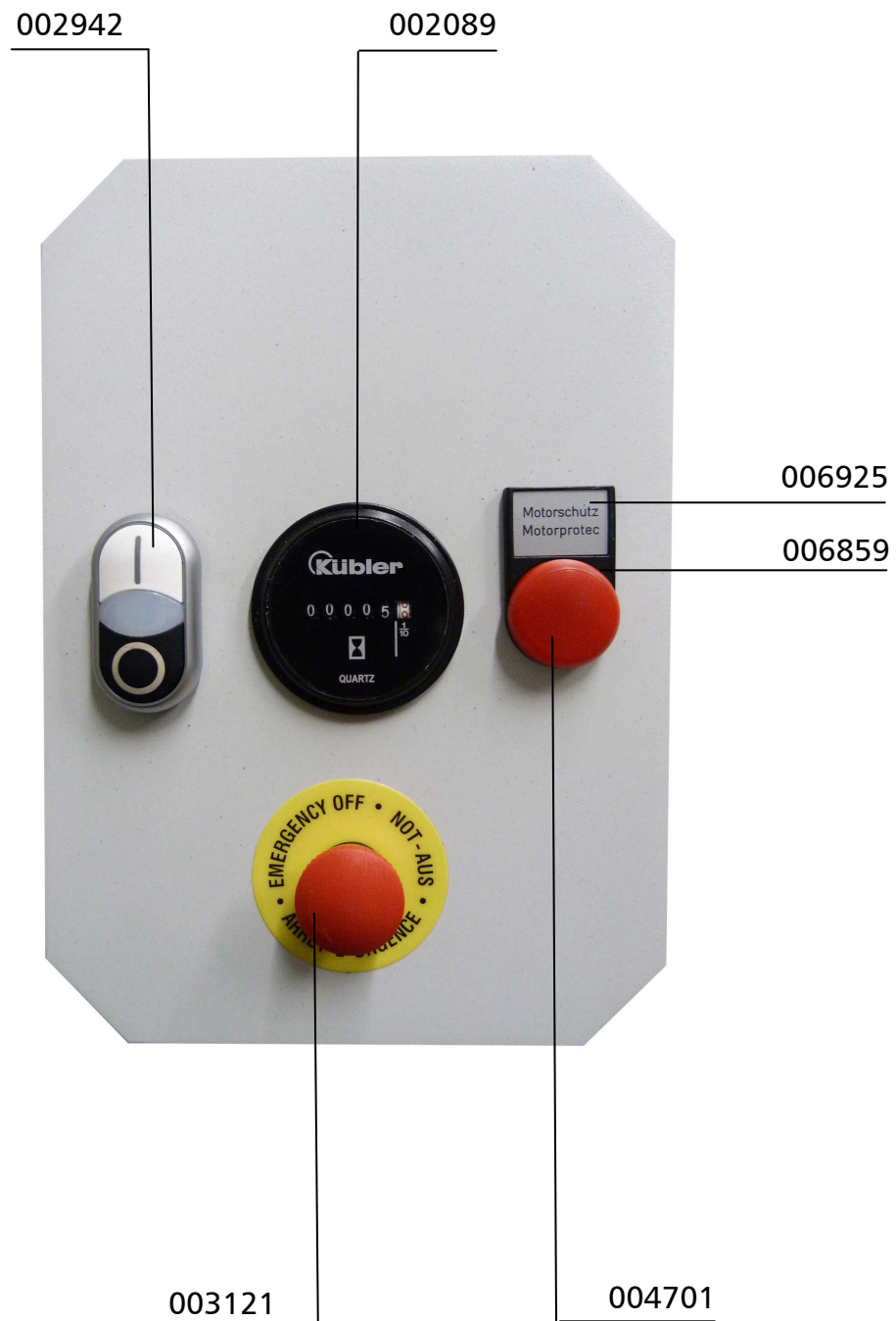

C



ERSATZTEILLISTE / SPARE PART LIST

Baugruppe: Kompressorblock / Assembly: Compressor Block

Best.-Nr. / Order No.	Benennung	Description
000205	Kurbelgehäuseentlüftungsventil	Crankcase Breather Valve
000257	Obere Ventildichtung, 1. Stufe	Upper Valve Gasket, Paper, 1st
000258	Untere Ventildichtung	Lower Valve Gasket, Copper
000432	Ölmesstab	Oil Dip Stick LW 280
000542	Saug- & Druckventil, 2. Stufe komplett	In- & Outlet Valve, 2nd Stage
000543	Saug-Druckventil kompl.mit Aludichtungen	In- & Outlet Valve, 3rd Stage
000761	Verschraubung	Elbow Connection
000765	Schneidring	Olive Seal
000766	Mutter	Nut
000783	Verschraubung	Straight Connection
000811	Verschraubung	Elbow Connection WE3/8"/12L
000863	Winkelverschraubung 90°	Elbow Connection
000967	Zylinderschraube	Allen Bolt
001041	Zylinderschraube	Allen Screw
001069	Zylinderschraube	Allen Bolt
001088	Zylinderschraube	Hexagon Bolt
001164	Stopfmutter	Lock Nut M10
001181	U-Scheibe A8	Washer A8
001186	U-Scheibe A10	Washer A10
001189	Schnorr-Scheibe S10	Clamp Washer S10
001275	O-Ring	O-Ring guide cylinder 280
001284	O-Ring	O-Ring 60x4
001310	O-Ring,	O-Ring 105x4
001314	O-Ring	O-Ring
001315	O-Ring	O-Ring
001323	CU-Ring	Copper Seal Ring
001384	Kompressorblock LW280 mit Testlauf	Compressor Block LW280
001623	Zylinder 3. Stufe	Cylinder 3rd Stage
001650	Gehäusedeckel	Crankcase Cover



ERSATZTEILLISTE / SPARE PART LIST

Baugruppe: Kompressorblock / Assembly: Compressor Block

Best.-Nr. / Order No.	Benennung	Description
001660	Winkelverschraubung mit Düse	Elbow Connection c/w Jet
002093	Saug-und Druckventil, 1. Stufe	In & Outlet Valve 1st Stage
002096	Zylinder 1. Stufe	Cylinder, 1st Stage
002107	Zylinder 2. Stufe	Cylinder, 2nd Stage
002108	Führungszylinder 2. + 3. Stufe	Guide cylinder 2nd+3rd Stage
002121	Ventilkopf 2. Stufe	Valve head 2nd Stage
002124	Ventilkopf 3. Stufe	Valve head 3rd Stage
002154	T-Stück mit Düse (lang)	T-piece with injector (long)
002155	T-Stück mit Düse (kurz)	T-piece with injector (short)
002158	Ölrohr (Lagerflansch - 3. Stufe)	Oil Pipe (Flange - 3rd Stage)
002159	Ölrohr (Ölpumpe - Ölfilter)	Oil pipe (oil pump-oil filter)
002160	Ölrohr (Ölfilter - 2.Stufe)	Oil pipe (oil filt.-2nd Stage)
003583	Öldruckleitung 2. Stufe	Oil pipe 2nd stage
004982	Dichtring für Peilstab	Gasket seal for oil dipstick
005239	Verbindungsrohr	Connection pipe
005837	Sechskantschraube m. Schaft	Hexagon Bolt
005859	Gerade Einschraubverschraubung 6 mm	Straight Hose Connection 6 mm
007434	Entlüftungsschlauch Kurbelgehäuse	Crankcase Breather Hose
009852	Gewindestange M6x211mm	Threaded bar M6x211mm
011576	Ventilkopf 1. Stufe	Valve Head 1st Stage

DETAILANSICHT / DETAILED VIEW

Baugruppe: Kompressorblock / Assembly: Compressor Block

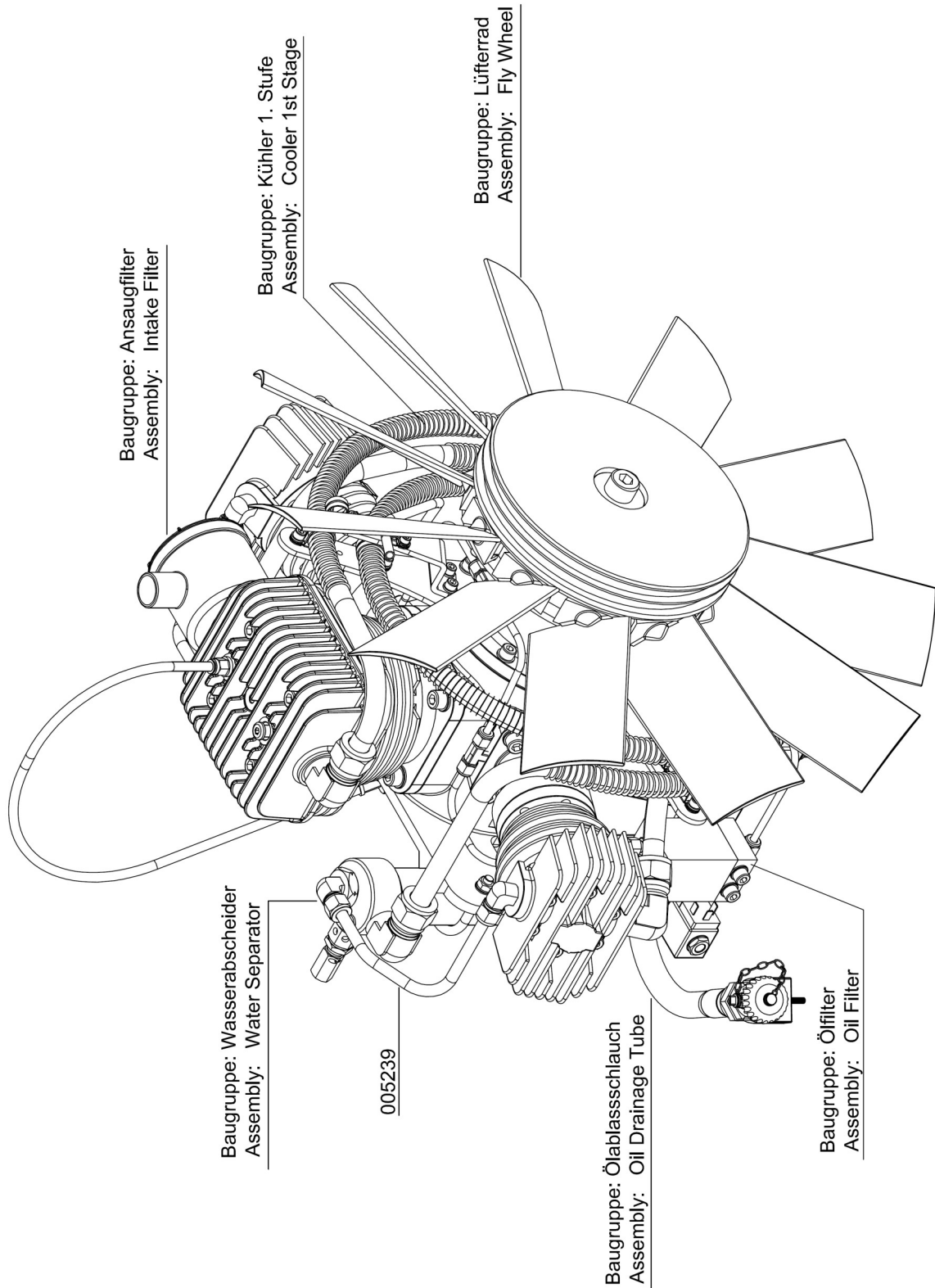

C

Baugruppe: Kompressorblock / Assembly: Compressor Block

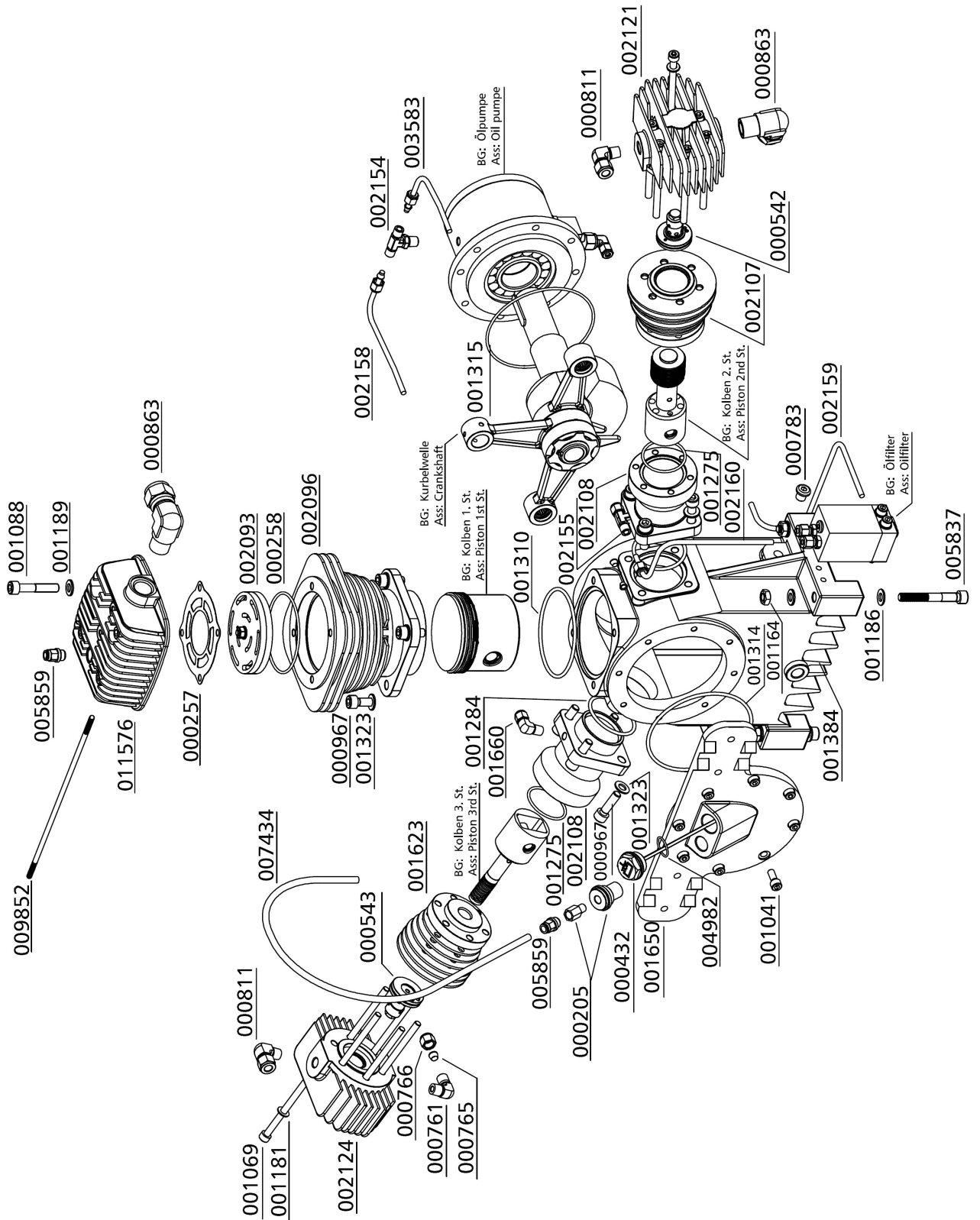



ERSATZTEILLISTE / SPARE PART LIST

Baugruppe: Wasserabscheider 1. und 2. Stufe

Assembly: Water Separator 1st and 2nd Stage

Best.-Nr. / Order No.	Benennung	Description
000220	Sicherheitsventil G3/8"	Safety Valve G3/8" 8 bar
000226	Sicherheitsventil G3/8"	Safety Valve G3/8" 60 bar
000391	U-Sit Ring,	Seal Ring U-Sit
000811	Verschraubung	Elbow Connection WE3/8"/12L
000837	Verschlussstopfen	Plug
000863	Winkelverschraubung 90°	Elbow Connection
001159	Stopfmutter	Lock Nut M8
001181	U-Scheibe A8	Washer A8
001255	O-Ring	O-Ring
002123	Sinterfilter G3/8" AG, 1. + 2. Stufe	Sinterfilter G3/8" 1st+2nd St.
002128	Wasserabscheider, 1. und 2. Stufe	Water separa. 1st + 2nd Stage
002130	Halter für Sinterfilter G3/8"	Holder for Sinterfilter G3/8"
002150	Haltebügel für Wasserabweiser LW280	U-Clamp Water Separator
003077	Entwässerungsventil G1/4"	Drain Valve G1/4"

C

DETAILANSICHT / DETAILED VIEW

Baugruppe: Wasserabscheider 1. und 2. Stufe

Assembly: Water Separator 1st and 2nd Stage

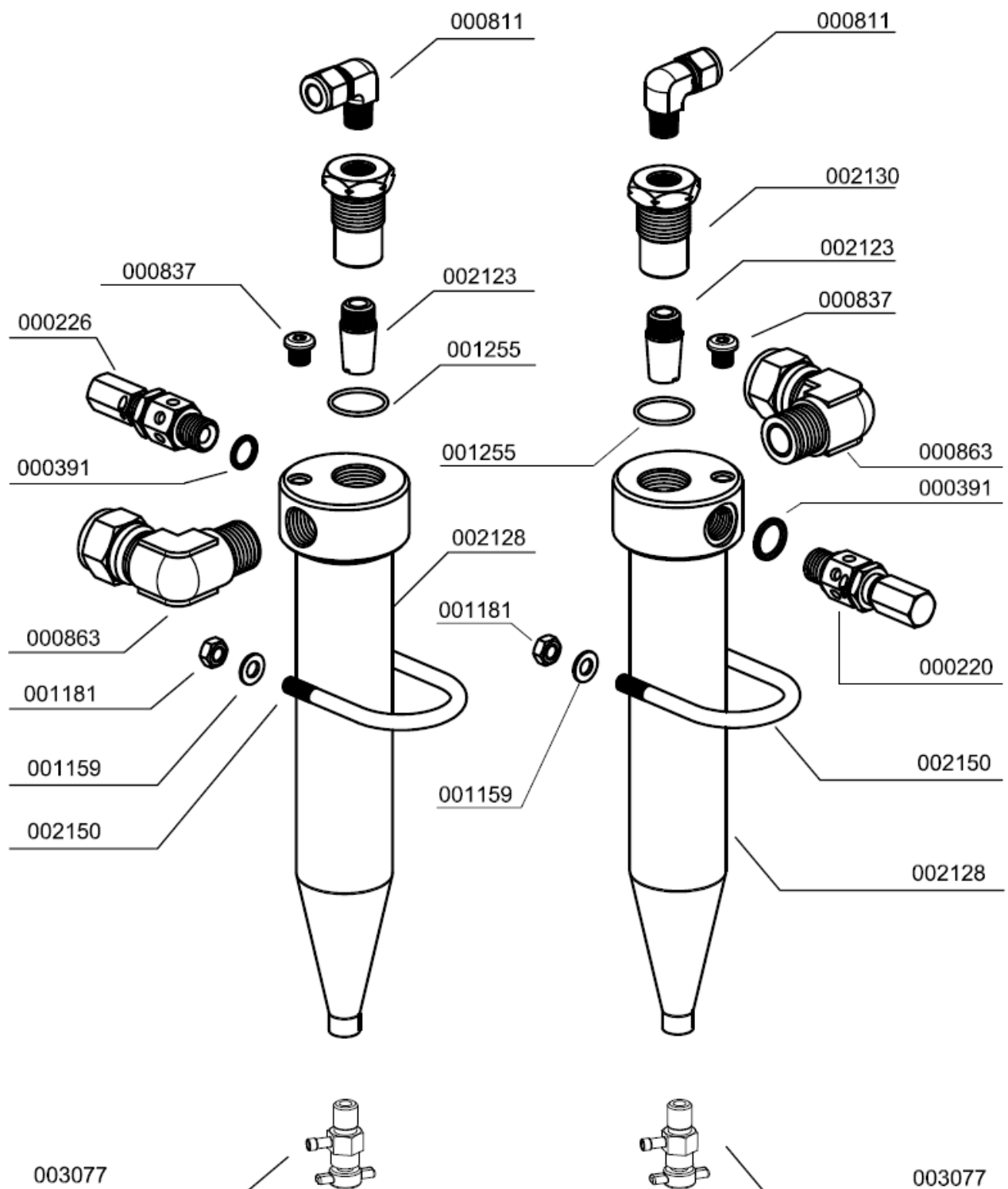



ERSATZTEILLISTE / SPARE PART LIST

Baugruppe: Wasserabscheider 1. und 2. Stufe

Assembly: Water Separator 1st and 2nd Stage

Best.-Nr. / Order No.	Benennung	Description
000220	Sicherheitsventil G3/8"	Safety Valve G3/8" 8 bar
000226	Sicherheitsventil G3/8"	Safety Valve G3/8" 60 bar
000391	U-Sit Ring,	Seal Ring U-Sit
000811	Verschraubung	Elbow Connection WE3/8"/12L
000837	Verschlussstopfen	Plug
000863	Winkelverschraubung 90°	Elbow Connection
001159	Stopfmutter	Lock Nut M8
001181	U-Scheibe A8	Washer A8
001255	O-Ring	O-Ring
002123	Sinterfilter G3/8" AG, 1. + 2. Stufe	Sinterfilter G3/8" 1st+2nd St.
002128	Wasserabscheider, 1. und 2. Stufe	Water separa. 1st + 2nd Stage
002130	Halter für Sinterfilter G3/8"	Holder for Sinterfilter G3/8"
002150	Haltebügel für Wasserabweiser LW280	U-Clamp Water Separator
003077	Entwässerungsventil G1/4"	Drain Valve G1/4"

C

DETAILANSICHT / DETAILED VIEW

Baugruppe: Wasserabscheider 1. und 2. Stufe

Assembly: Water Separator 1st and 2nd Stage

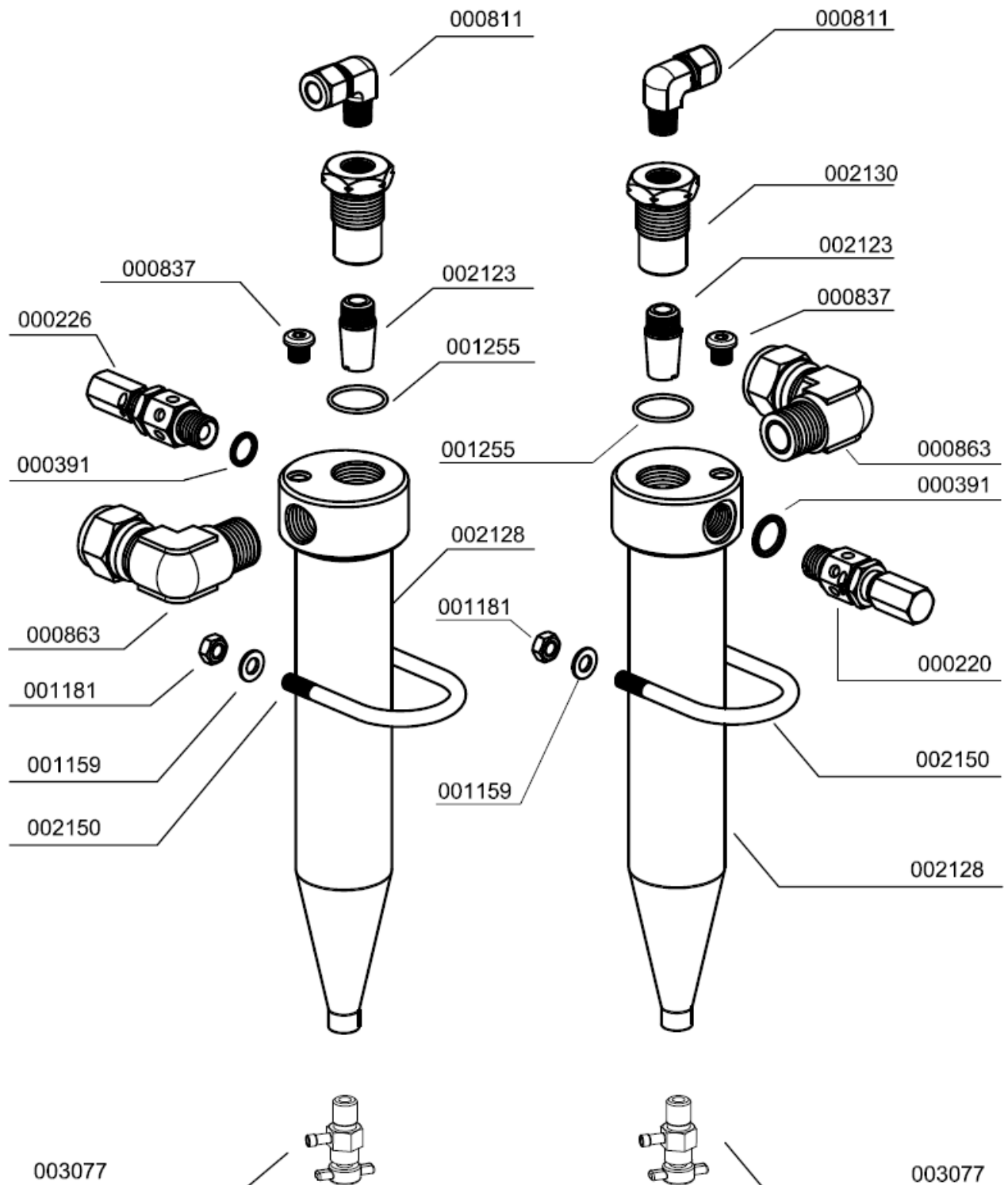



ERSATZTEILLISTE / SPARE PART LIST

Baugruppe: Filtergehäuse 1,7 l / Assembly: Filter housing 1.7 ltr

Best.-Nr. / Order No.	Benennung	Description
000002	Filterpatrone 1,7 Liter	Filter Cartridge 1.7 ltr BA
000272	Abstandshalter für Filtergehäuse	Spacer Bracket for Filtertower
000383	Messing Adapter für Filterpatrone	Brass Filter Adapter
000384	Düse für Filtergehäuse	Jet Filter Housing
000761	Verschraubung	Elbow Connection
000765	Schneidring	Olive Seal
000766	Mutter	Nut
001160	Hutmutter	Domed Nut M8
001181	U-Scheibe A8	Washer A8
001184	Schnorr-Scheibe	Clamp Washer S8
001285	Stützring, Filtergehäuse	Back-up Ring Filter Housing
001287	O-Ring, Filtergehäuse	O-Ring filter housing
002140	Filterschlüssel 1,7 & 2,3 Liter Behälter	Filter tool 1,7 & 2,3 Litre
002147	Haltebügel für Filtergehäuse (ES)	U-Clamp for filter housing ES
002366	Filtergehäuse	Filter housing
003077	Entwässerungsventil G1/4"	Drain Valve G1/4"
005244	O-Ring	O-Ring

C

DETAILANSICHT / DETAILED VIEW

Baugruppe: Filtergehäuse 1,7 l / Assembly: Filter housing 1.7 ltr

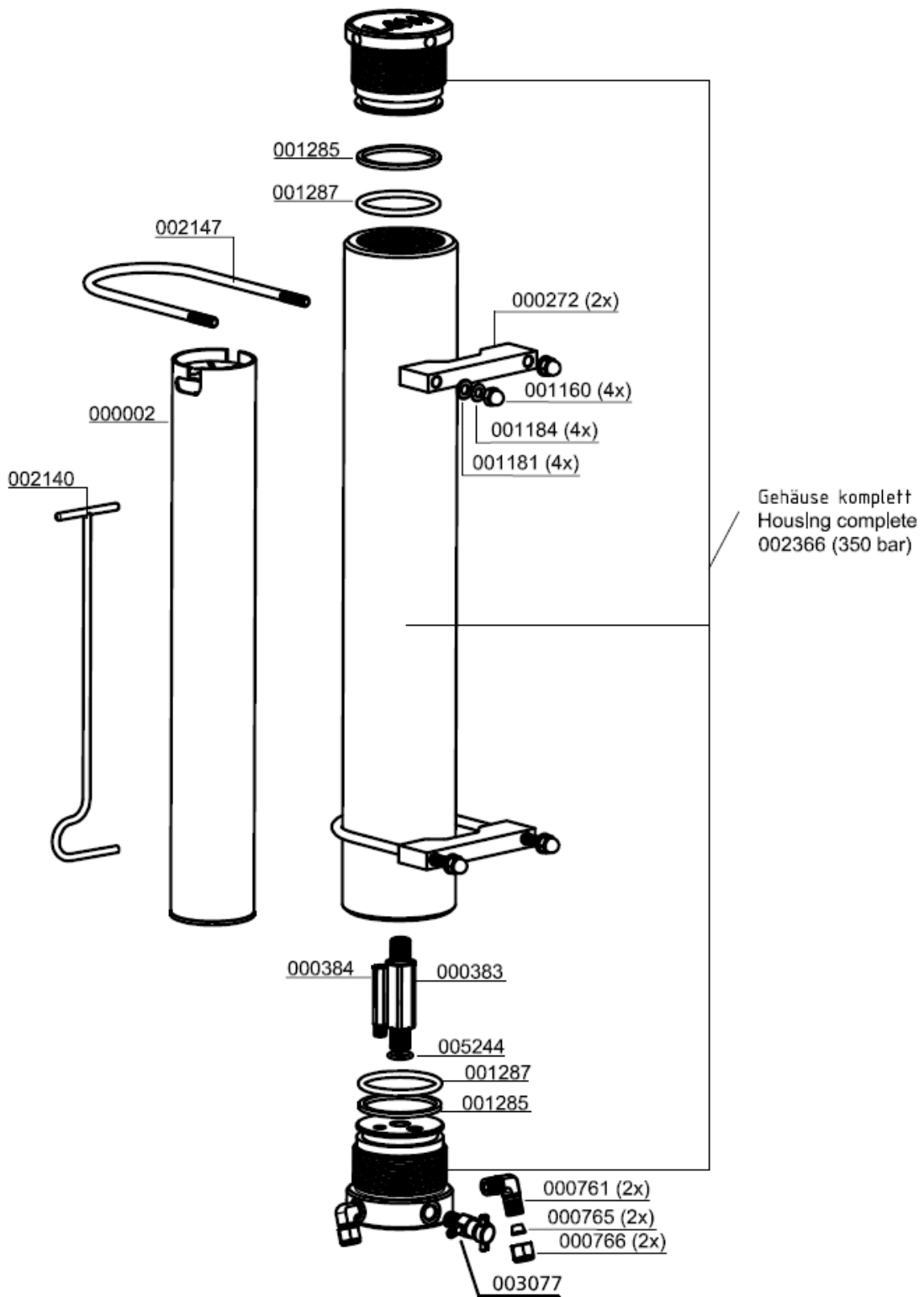

C



ERSATZTEILLISTE / SPARE PART LIST

Baugruppe: Ansaugfilter / Intake Filter

Best.-Nr. / Order No.	Benennung	Description
000170	Ansaugfilterpatrone	Air Intake Filter Cartridge
001772	Flügelmutter, PVC-schwarz	Winged Nut, PVC black
001782	O-Ring, Ansaugfiltergehäuse	O-Ring, Intake Filter Housing
009652	Gehäuse für Ansaugfilter	Intake Filter Housing
009653	Deckel für Ansaugfilter	Cover Intake filter housing
009658	O-Ring	O-Ring

C

DETAILANSICHT / DETAILED VIEW

Baugruppe: Ansaugfilter / Intake Filter

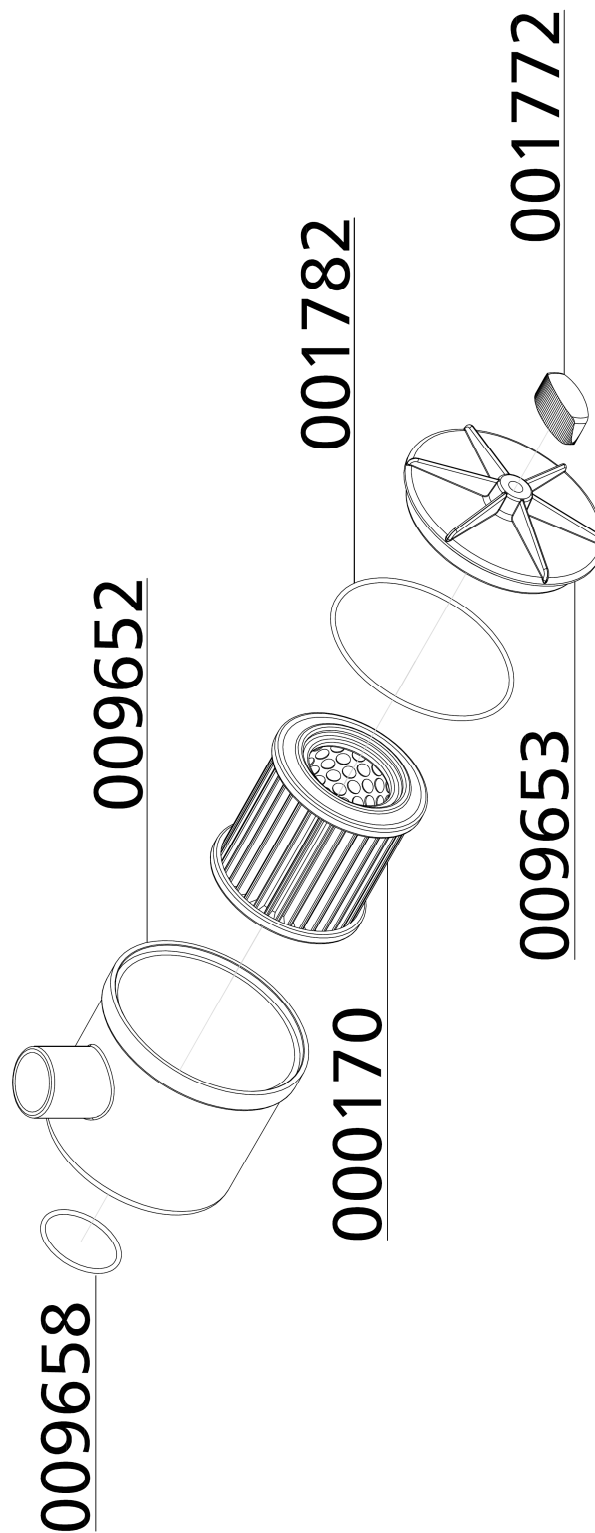

C



ERSATZTEILLISTE / SPARE PART LIST

Baugruppe: Sicherheitsventil / Assembly: Safety Valve

Best.-Nr. / Order No.	Benennung	Description
000165	Gehäuse Rückschlagventil	Body Non-Return Valve
000233	Sockel für Sicherheitsventil mit TÜV/CE	Base f. Safety Valve TÜV type
000553	Sicherheitsventil - Bauteilgeprüft	Safety Valve TÜV 225 bar
000554	Sicherheitsventil - Bauteilgeprüft	Safety Valve TÜV 250 bar
000555	Sicherheitsventil - Bauteilgeprüft	Safety Valve TÜV 300 bar
000556	Sicherheitsventil - Bauteilgeprüft	Safety Valve TÜV 330 bar
000557	Sicherheitsventil - Bauteilgeprüft	Safety Valve TÜV 350 bar
000738	Verschraubung	Connection
000762	Verschraubung	Elbow Connection
000765	Schneidring	Olive Seal
000766	Mutter	Nut
001044	Zylinderschraube	Allen Screw
001058	Zylinderschraube	Allen Bolt
001158	Mutter	Nut M8
001181	U-Scheibe A8	Washer A8
001244	O-Ring	O-Ring, flange safety valve
001814	Sicherheitsventil - Bauteilgeprüft	Safety Valve
001815	Sicherheitsventil - Bauteilgeprüft	Safety Valve
001816	Sicherheitsventil - Bauteilgeprüft	Safety Valve
001817	Sicherheitsventil - Bauteilgeprüft	Safety Valve

C

ERSATZTEILLISTE / SPARE PART LIST

Baugruppe: Sicherheitsventil / Assembly: Safety Valve

Druck/ Pressure	SV-Ventil mit CE-Prüfung/ Safety Valve with CE	SV-Ventil mit TÜV-Prüfung/ Safety Valve with TÜV
225 bar	001814	000553
250 bar	001815	000554
285/300 bar	_____	000555
330 bar	001816	000556
350 bar	001817	000557

Sonder-Einstelldrücke auf Anfrage! /

Special relieve pressures are available on request!

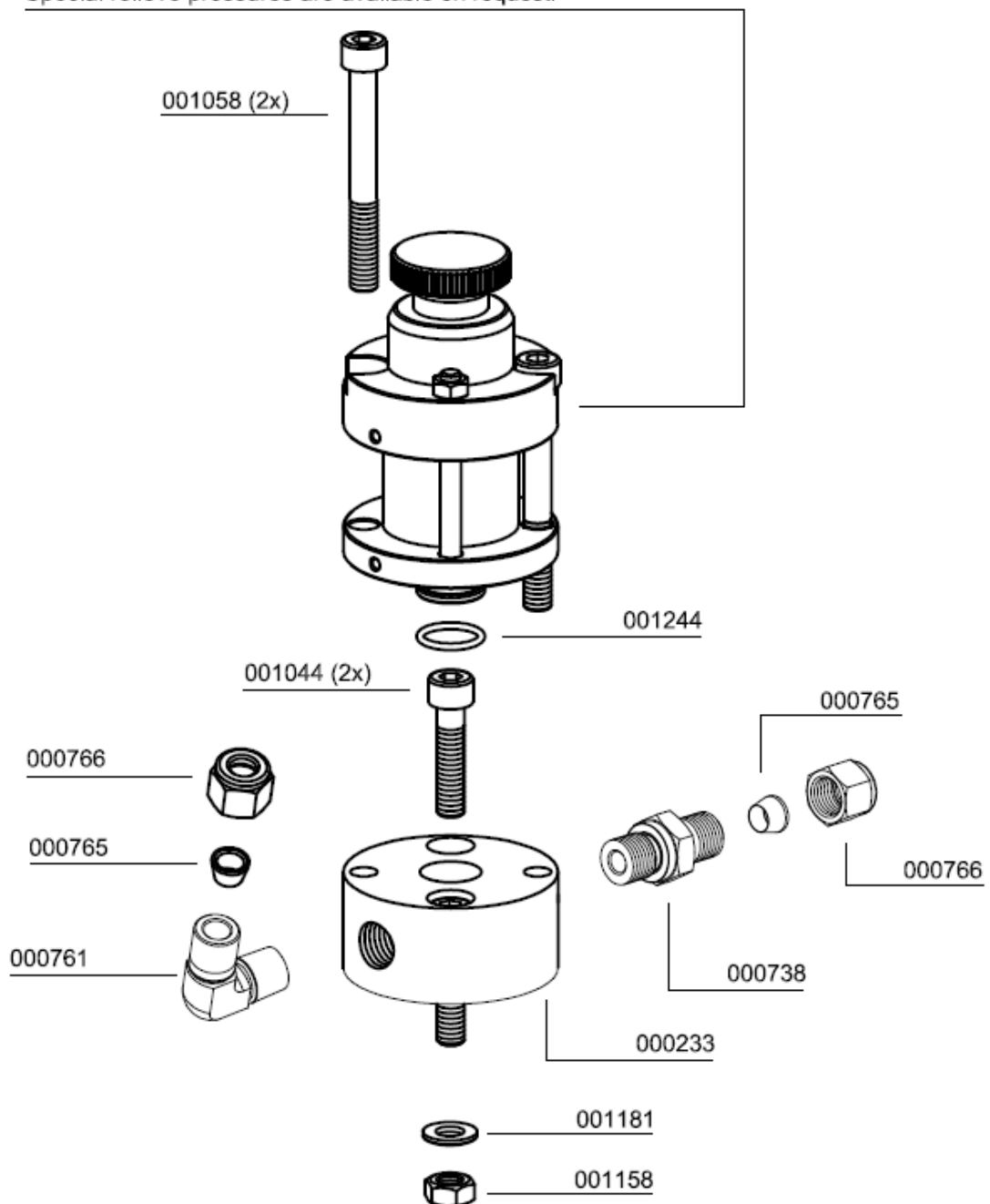



ERSATZTEILLISTE / SPARE PART LIST

Baugruppe: Pneumatisches Kondensatventil

Assembly: Pneumatic Condensate Valve

Best.-Nr. / Order No.	Benennung	Description
000188	Sinterfilter, pneum. Kondensatventil	Sintered Filter
000191	Steuerkolben, pneum. Kondensatventil	Piston
000194	Reparatursatz pneum. Kondensatventil	Repair Kit Condensate Valve
000196	Düsenerschraube, pneum. Kondensatventil	Inlet Jet Screw
000197	Stopfen, pneum. Kondensatventil	Plug
000198	Gehäuse, pneum. Kondensatventil	Body PCV
000199	Pneum. Kondensatventil (Kondensatablas.)	Pneumatic Condensate Valve
000498	U-Scheibe A6	Washer A6
000721	Verschraubung	Connection
000732	Mutter	Union Nut 06L
000733	Schneidring	Olive Seal SR 06 (Ø 6mm)
000737	Verschraubung	Connection
000738	Verschraubung	Connection
000765	Schneidring	Olive Seal
000766	Mutter	Nut
001011	Zylinderschraube	Allen Bolt

C

DETAILANSICHT / DETAILED VIEW

Baugruppe: Pneumatisches Kondensatventil

Assembly: Pneumatic Condensate Valve

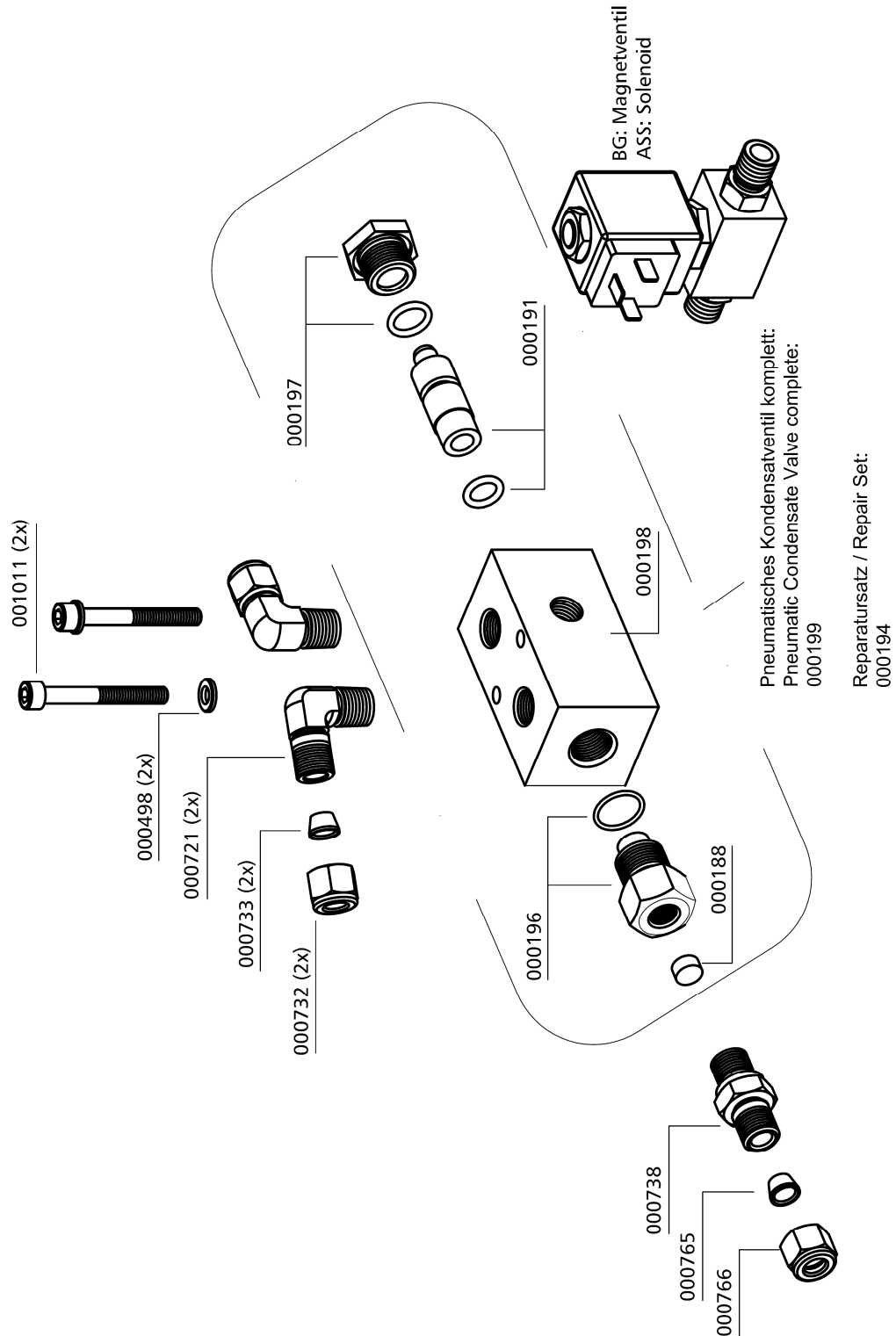



ERSATZTEILLISTE / SPARE PART LIST

Druckhalteventil / Pressure Maintaining Valve

Best.-Nr. / Order No.	Benennung	Description
000169	Druckhalterückschlagventil, schwarz	Pressure Maint. Valve black
000498	U-Scheibe DIN 125 A6	Washer DIN 125 A6
000506	Feder	Spring
000508	USIT Ring 13,7 x Ø20 x 1,5	Gasket Ring U-Sit 13,7 x Ø20 x 1,5
000511	Mutter, Druckhalterückschlagventil	Lock Nut PMV
000512	Schraube, Druckhalte-Rückschlagventil	Set Bolt PMV
000513	Druckstück für Druckhalteventil, Federadapter	Spring Adapter PMV, spring adapter
000514	Stift Druckhalte-/Rückschlagventil	Stud PMV
000515	Gehäuse, Druckhalte-Rückschlagventil	Main Body PMV
000516	Nutring, Druckhalterückschlagventil 5 x 10 x 5/2,5 90° Blau	Seal Ring PMV 5 x 10 x 5/2,5 90° blue
000517	Feder, Druckhalterückschlagventil	Coil Spring PMV
000518	Unterlegscheibe, Messing	Washer, Brass
000519	Dichtkappe, Druckhalte Rückschlagventil, schwarz	Plastic Seal Piston PMV, black
000520	Hohlschraube, DHRV	Inlet Jet PMV
000765	Schneidring PSR 08 LX	Olive Seal PSR 08 LX
000767	Mutter 08 S	Union Nut 08 S
001023	Zylinderschraube	Allen Bolt

DETAILANSICHT / DETAILED VIEW

Druckhalteventil / Pressure Maintaining Valve

**Reparatursatz
003548:**

Bestehend aus:
Gelbmarkierte
Bestellnummern

**Repair kit
003548:**

Consists of:
Yellow marked
P/N's

000169 (complete)

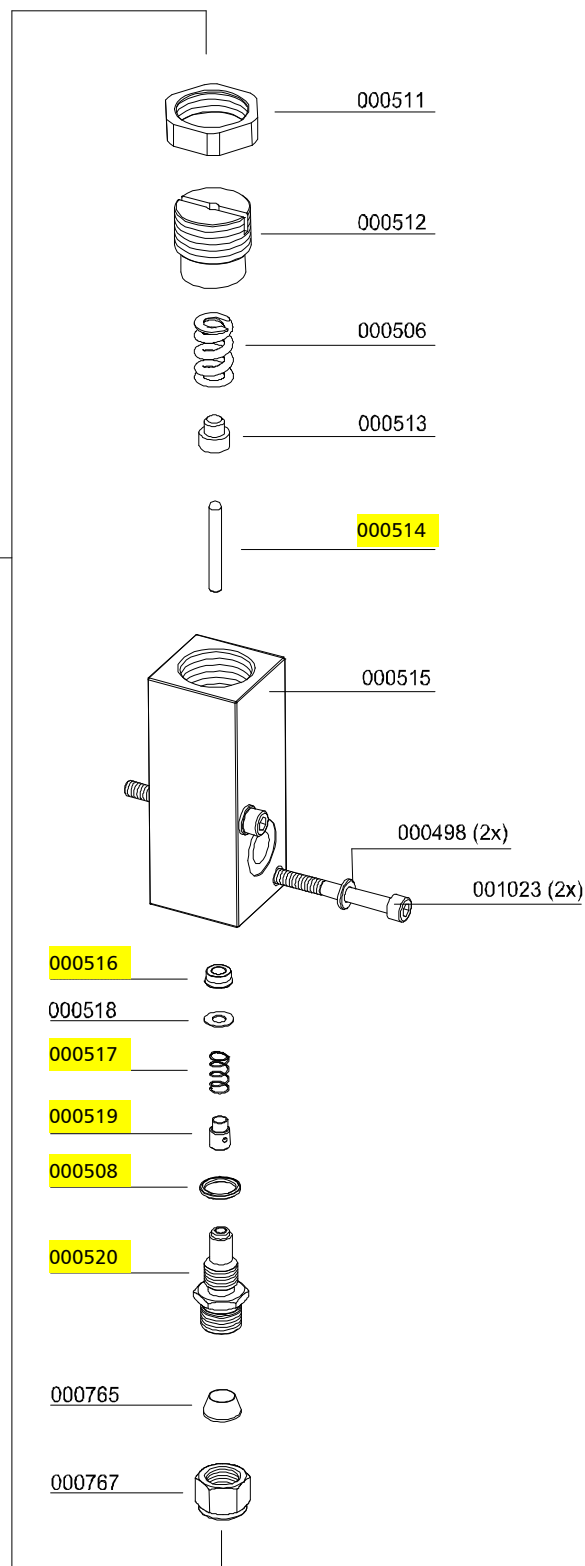

C



ERSATZTEILLISTE / SPARE PART LIST

Baugruppe: Ölfilter / Assembly: Oil Filter

Best.-Nr. / Order No.	Benennung	Description
000184	Sinterfilter Wasserabscheider	Siltered Filter, Oil Filter
000434	Gehäuse (Ölfiltergehäuse)	Body Oil Filter Housing
000435	O-Ring, Ölfiltergehäuse	O-Ring
000436	Filterscheibe Ölfiltergehäuse	Filter Disk (oil filter assy)
000437	Filterdeckel Ölfiltergehäuse	Filter Cover (oil filter assy)
000438	Stiftschraube Ölfiltergehäuse	Threaded Bolt, oil filter assy
000440	Ölfilter kompl.	Oil Filter Unit LW 280
000498	U-Scheibe A6	Washer A6
000710	Verschraubung	Connection w/o nut& olive seal
000721	Verschraubung	Connection
000732	Überwurfmutter 6L	Nut 6L
001029	Zylinderschraube	Allen Bolt
001056	Zylinderschraube	Allen Bolt
001156	Stoppmutter	Lock Nut M6
001181	U-Scheibe A8	Washer A8
002395	Verschlusskegel 06mm	Locking cone 06mm

C

DETAILANSICHT / DETAILED VIEW

Baugruppe: Ölfilter / Assembly: Oil Filter

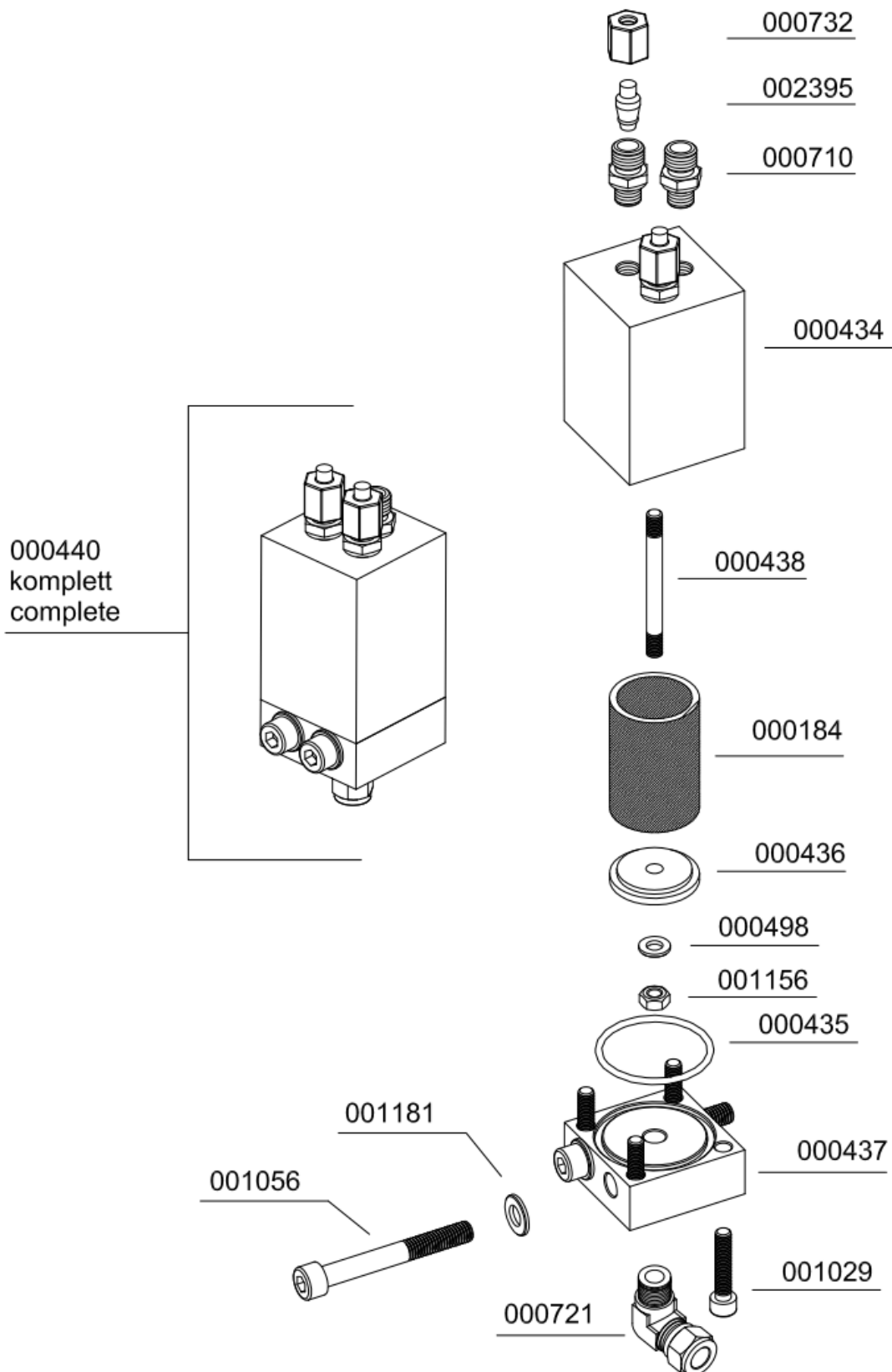

C



ERSATZTEILLISTE / SPARE PART LIST

Baugruppe: Ölpumpe / Assembly: Oil Pump

Best.-Nr. / Order No.	Benennung	Description
000426	Distanzbuchse, (Hauptlager)	Spacer Tube
000427	Nocke, (Hauptlager)	Cam Bush
000428	Hauptlager, (Kugellager)	Main Ball Bearing
000429	Buchse für Wellendichtring	Sleeve for Seal Ring
000430	O-Ring	O-Ring
001027	Zylinderschraube	Allen Bolt
001263	O-Ring	O-Ring
001305	O-Ring	O-Ring Viton
001667	Ölpumpe kompl.	Oil Pump, compl. Assembly
002146	Lagerflansch	Bearing flange
002162	Hauptlager	Main bearing
002163	Simmerringdeckel	Cover Shaft Seal
002165	Radial-Wellendichtring	Radial shaft seal

C

DETAILANSICHT / DETAILED VIEW

Baugruppe: Ölpumpe / Assembly: Oil Pump

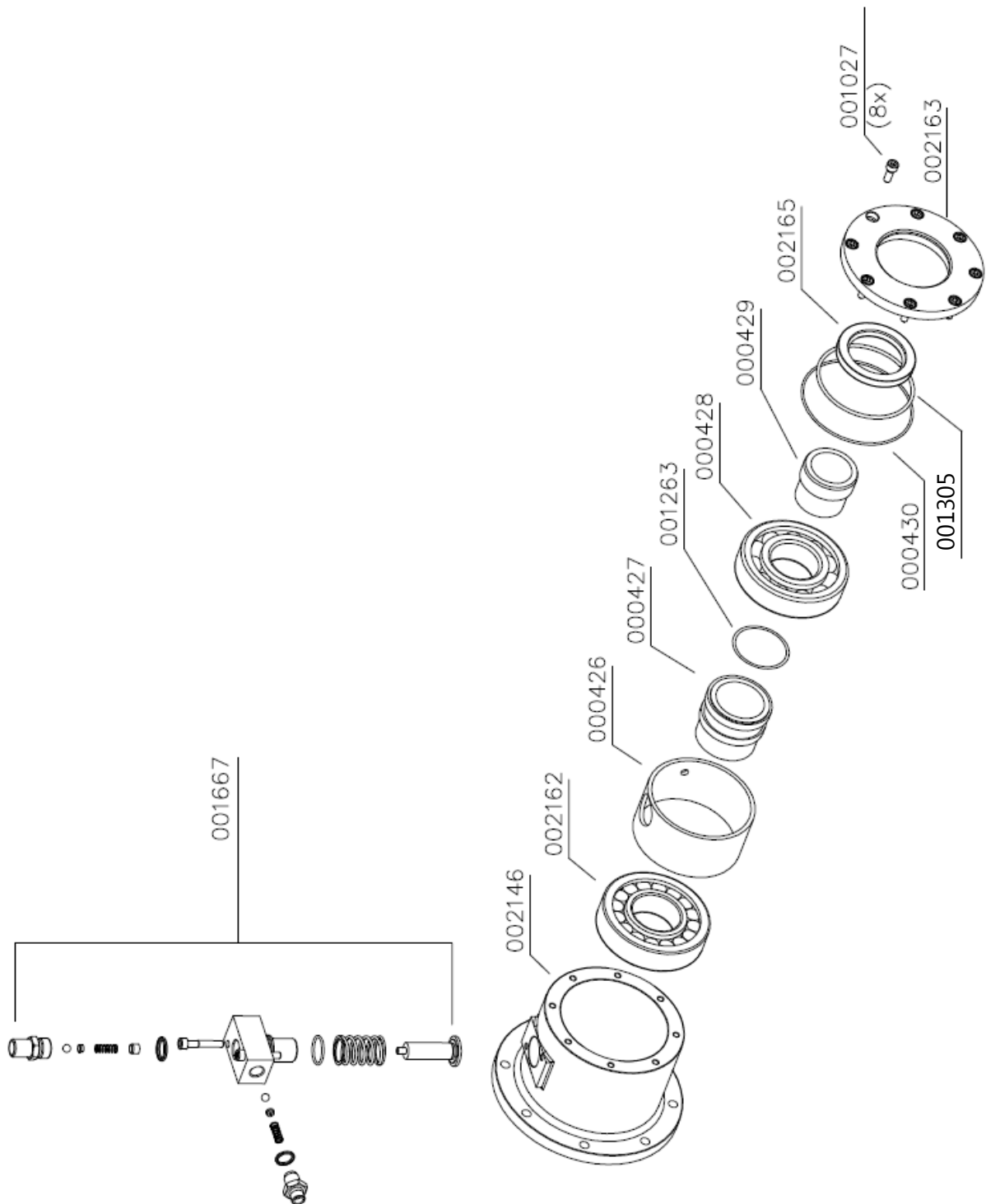



ERSATZTEILLISTE / SPARE PART LIST

Baugruppe: Kolben 1. Stufe / Assembly: Piston 1st Stage

Best.-Nr. / Order No.	Benennung	Description
000265	Kolbenringe 1. Stufe, Satz/3 Stk.	Piston Ring Set 3 pcs
001356	Sicherungsring	Circlip I22
002094	Kolben kompl. mit Ringen,Bolzen 1. Stufe	Piston, compl. 1st Stage
003900	Kolbenbolzen, 1. Stufe	Piston pin, 1st stage

C

DETAILANSICHT / DETAILED VIEW

Baugruppe: Kolben 1. Stufe / Assembly: Piston 1st Stage

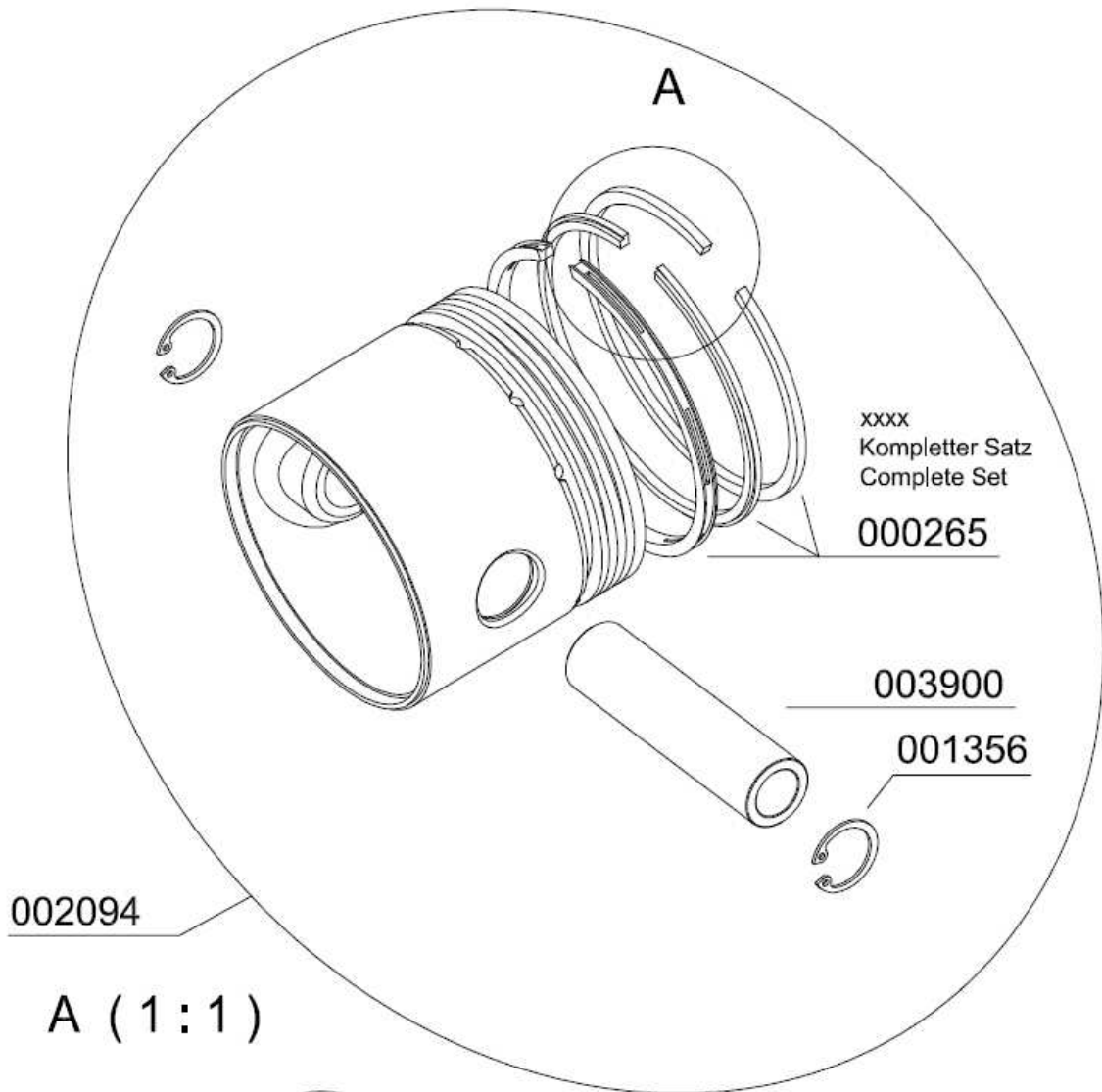

C



ERSATZTEILLISTE / SPARE PART LIST

Baugruppe: Kolben 2. Stufe / Assembly: Piston 2nd Stage

Best.-Nr. / Order No.	Benennung	Description
001353	Sicherungsring	Circlip I16
002109	Kolben 2. Stufe, kompl. mit Kolbenringe	Piston (c/w) rings 2nd Stage
002122	Kolbenbolzen, 2. + 3. Stufe	Piston pin, 2nd + 3rd Stage
002805	Kolbenringe 2. Stufe Satz	Set of piston rings 2nd stage
002948	Führungskolben 2. / 3. Stufe	Guide piston 2nd + 3rd stage

C

DETAILANSICHT / DETAILED VIEW

Baugruppe: Kolben 2. Stufe / Assembly: Piston 2nd Stage

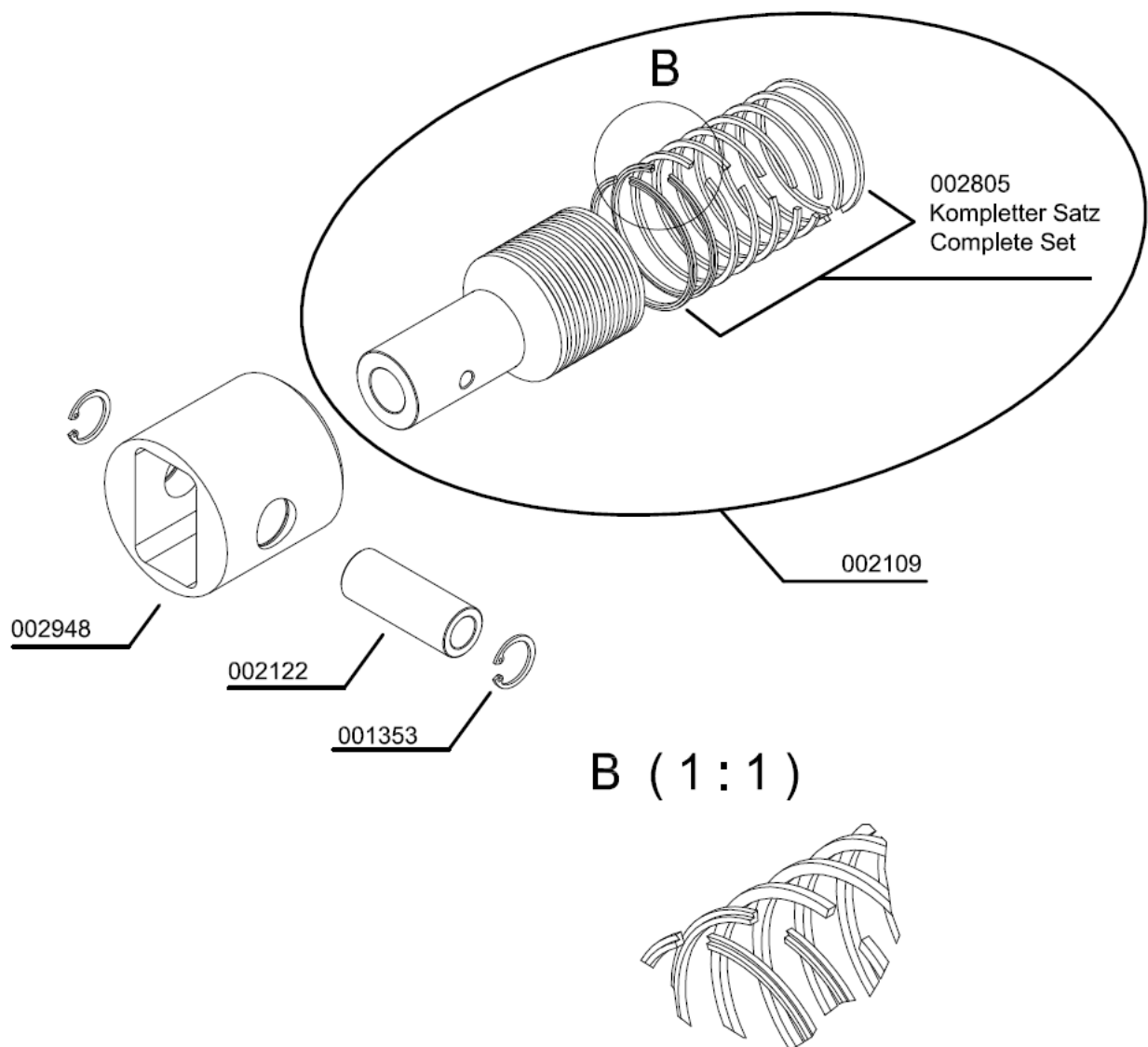

C



ERSATZTEILLISTE / SPARE PART LIST

Baugruppe: Kolben 3. Stufe / Assembly: Piston 3rd Stage

Best.-Nr. / Order No.	Benennung	Description
001353	Sicherungsring	Circlip I16
002122	Kolbenbolzen, 2. + 3. Stufe	Piston pin, 2nd + 3rd Stage
002125	Kolben inkl. Kolbenringe, 3. Stufe	Piston c/w rings 3rd Stage
002324	Kolbenringe 3. Stufe Satz/9Stk.	Piston rings, 3rd Stage
002948	Führungskolben 2. / 3. Stufe	Guide piston 2nd + 3rd stage

C

DETAILANSICHT / DETAILED VIEW

Baugruppe: Kolben 3. Stufe / Assembly: Piston 3rd Stage

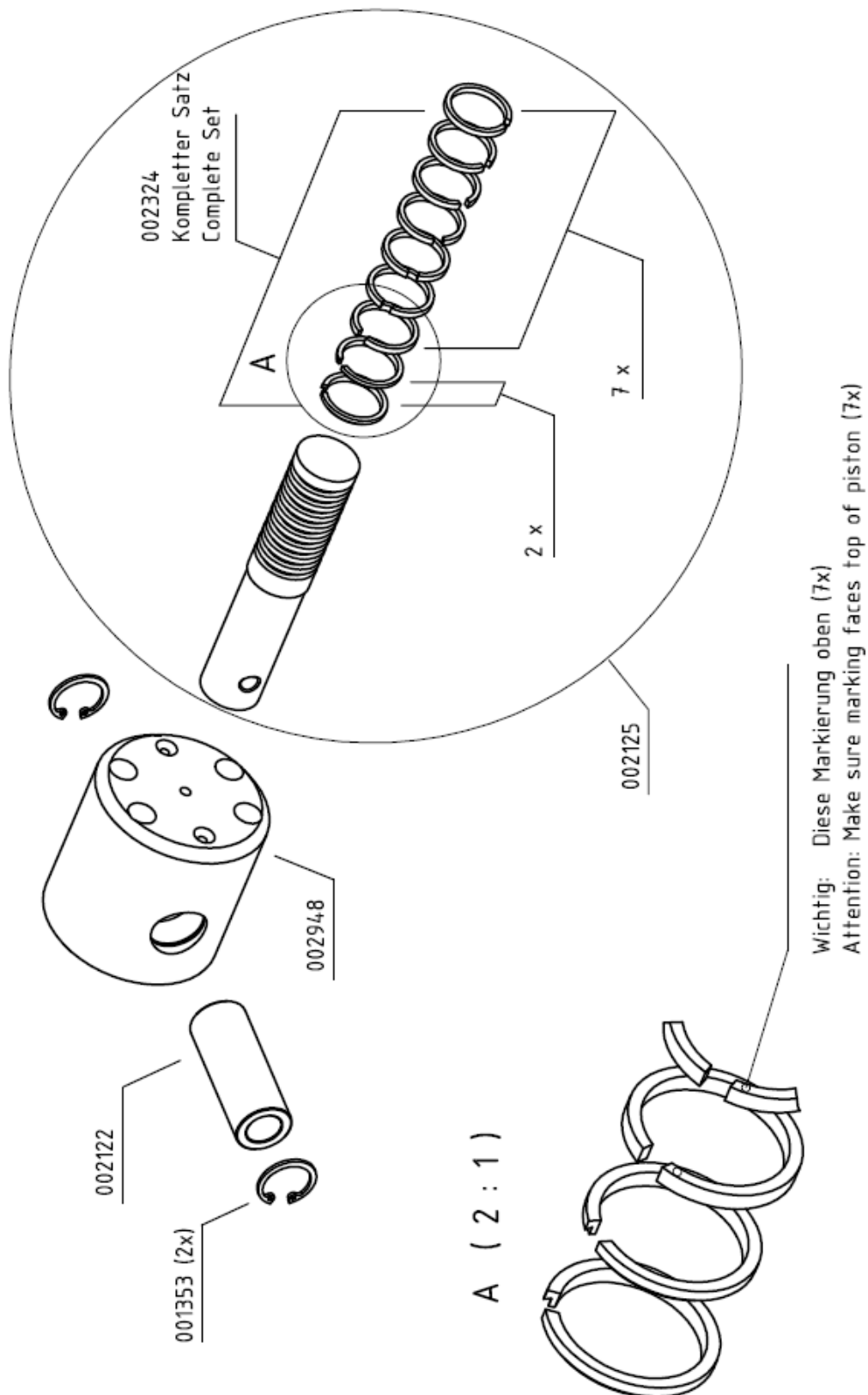

C



ERSATZTEILLISTE / SPARE PART LIST

Baugruppe: Kurbelwelle / Assembly: Crankshaft

Best.-Nr. / Order No.	Benennung	Description
001209	Passfeder	Woodruff Key
001304	Anlaufscheibe vordere (sternförmig)	Thrust Washer, Star shaped
001308	Anlaufscheibe hintere	Thrust Washer - rear side
001343	Sicherungsring	Circlip A35
001503	Kurbelwelle	Crank Shaft
001673	Pleuel 2.+3. Stufe	Connecting Rod 2nd/3rd Stage
001674	Pleuel 1. Stufe	Connecting Rod 1st Stage
002149	Pleuellager oberes	Small end bearing
002164	Pleuellager unteres	Big end bearing

C

DETAILANSICHT / DETAILED VIEW

Baugruppe: Kurbelwelle / Assembly: Crankshaft

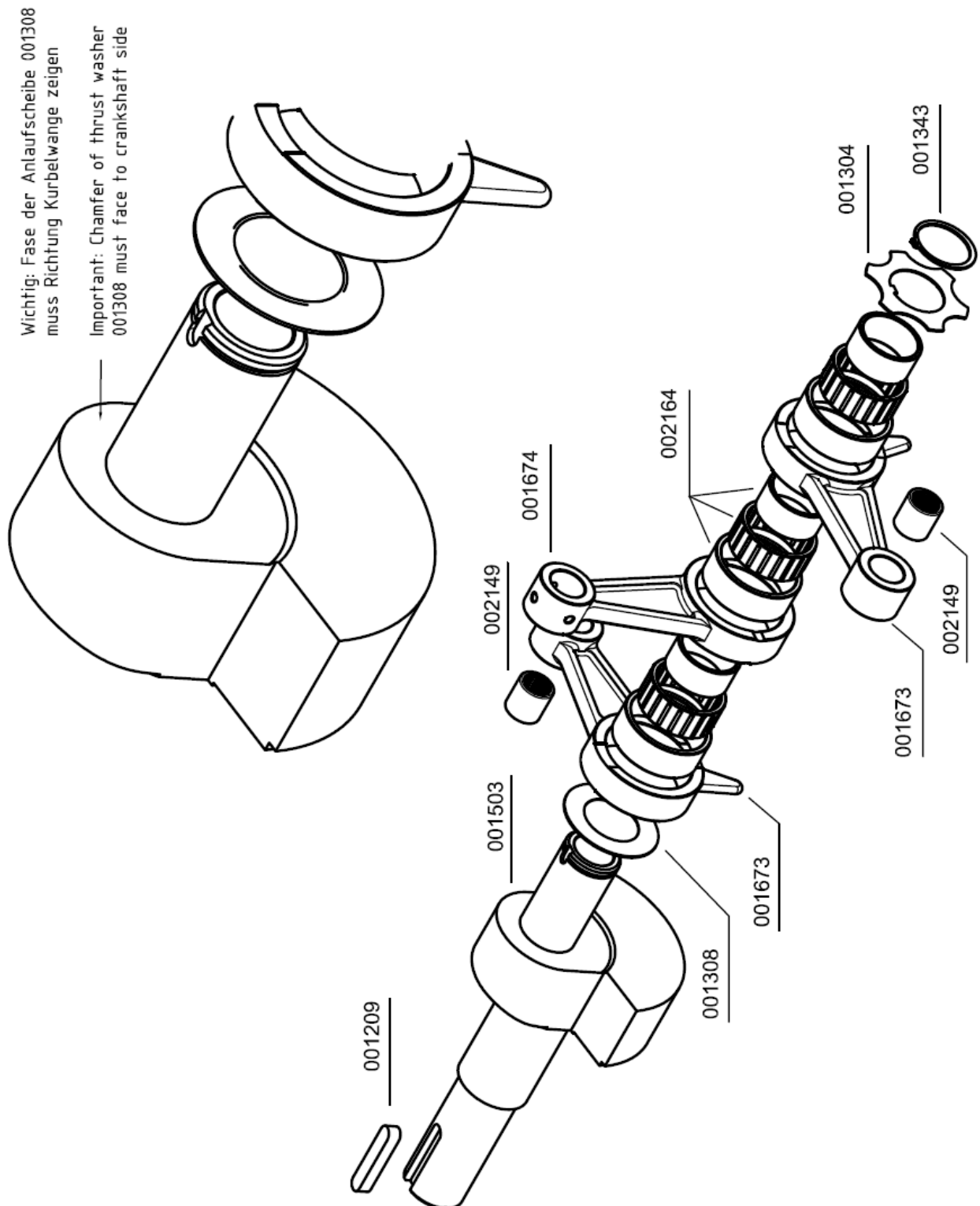



ERSATZTEILLISTE / SPARE PART LIST

Baugruppe: Kühlrohre / Assembly: Cooling Pipes

Best.-Nr. / Order No.	Benennung	Description
000498	U-Scheibe A6	Washer A6
000735	Verschraubung	Connection
000783	Verschraubung	Straight Connection
001004	Zylinderschraube	Allen Screw
001042	Zylinderschraube	Allen Screw
001043	Zylinderschraube	Allen Screw
001047	Zylinderschraube	Allen Bolt
001176	U-Scheibe A5	Washer A5
001181	U-Scheibe A8	Washer A8
001848	Rohrschelle (Ø15-18mm)	Pipe Clamp, 8mm Finned Pipe
007558	Verschraubung	Connection
008497	Rohrschelle Ø21 - 12 breit	Pipe Clamp
008656	Rohrschelle Ø8mm	P-Clip
010311	Kühlerhalterung 1.&2.Stufe - gerade(1)	Holder Cooler 1st & 2nd Stage
010312	Kühlerhalterung 1.&2.Stufe - quer(2)	Holder Cooler 1st & 2nd Stage
010313	Kühlerhalterung 1.&2.Stufe - quer1(3)	Holder Cooler 1st & 2nd Stage
010314	Kühlerhalterung 3.Stufe	Holder Cooler 3rd Stage
010582	Ölansaugrohr, Ø10mm	Oil Intake Pipe, Ø10mm
010583	Kühler 1.Stufe, Ø18mm CU-Rippenrohr	Cooler 1st Stage
010584	Kühler 2.Stufe, Ø18mm CU-Rippenrohr	Cooler 2nd Stage
010585	Kühler 3.Stufe, Ø8mm VA-Rippenrohr	Cooler 3rd Stage
010605	Rohrleitung Ø8mm, mit M. & S.	Pipe Ø8mm
010606	Kühler LW 280, komplett	Cooler LW 280, complete
010749	Rohrleitung Ø8mm, mit M. & S.	Pipe Ø8mm

DETAILANSICHT / DETAILED VIEW

Baugruppe: Kühlrohre / Assembly: Cooling Pipes

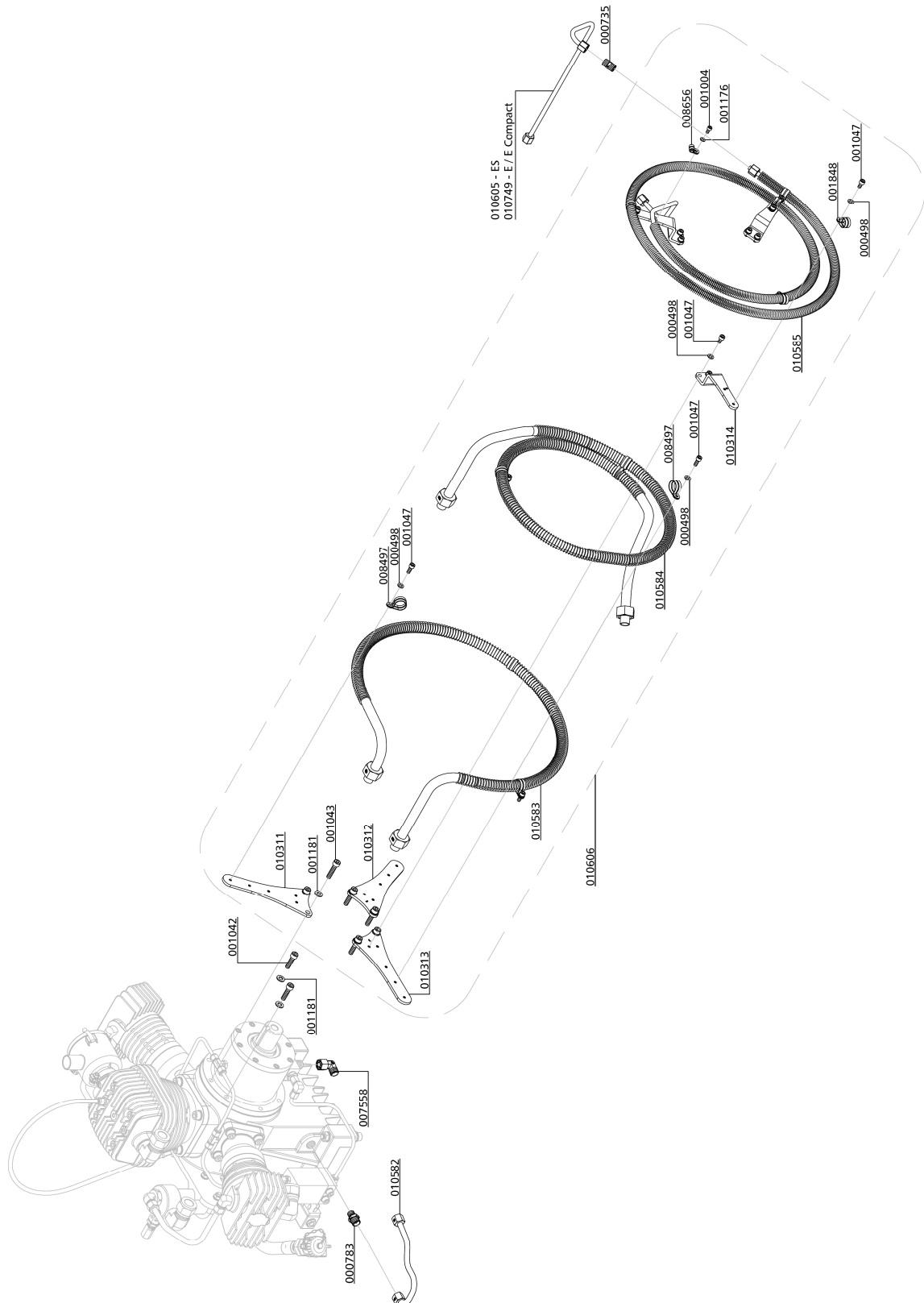



ERSATZTEILLISTE / SPARE PART LIST

Baugruppe: Lüfterrad / Assembly: Fan Wheel

Best.-Nr. / Order No.	Benennung	Description
000498	U-Scheibe A6	Washer A6
001026	Zylinderschraube	Allen Bolt
002335	Ventilatorflügelblatt, schwarz	Fan blade, black, new version
002336	Haltering Ventilatorflügel	Fan blade holder
003273	Schwungrad, inkl. Schrauben & Haltering	Flywheel c/w bolts & clamping

C

DETAILANSICHT / DETAILED VIEW

Baugruppe: Lüfterrad / Assembly: Fan Wheel

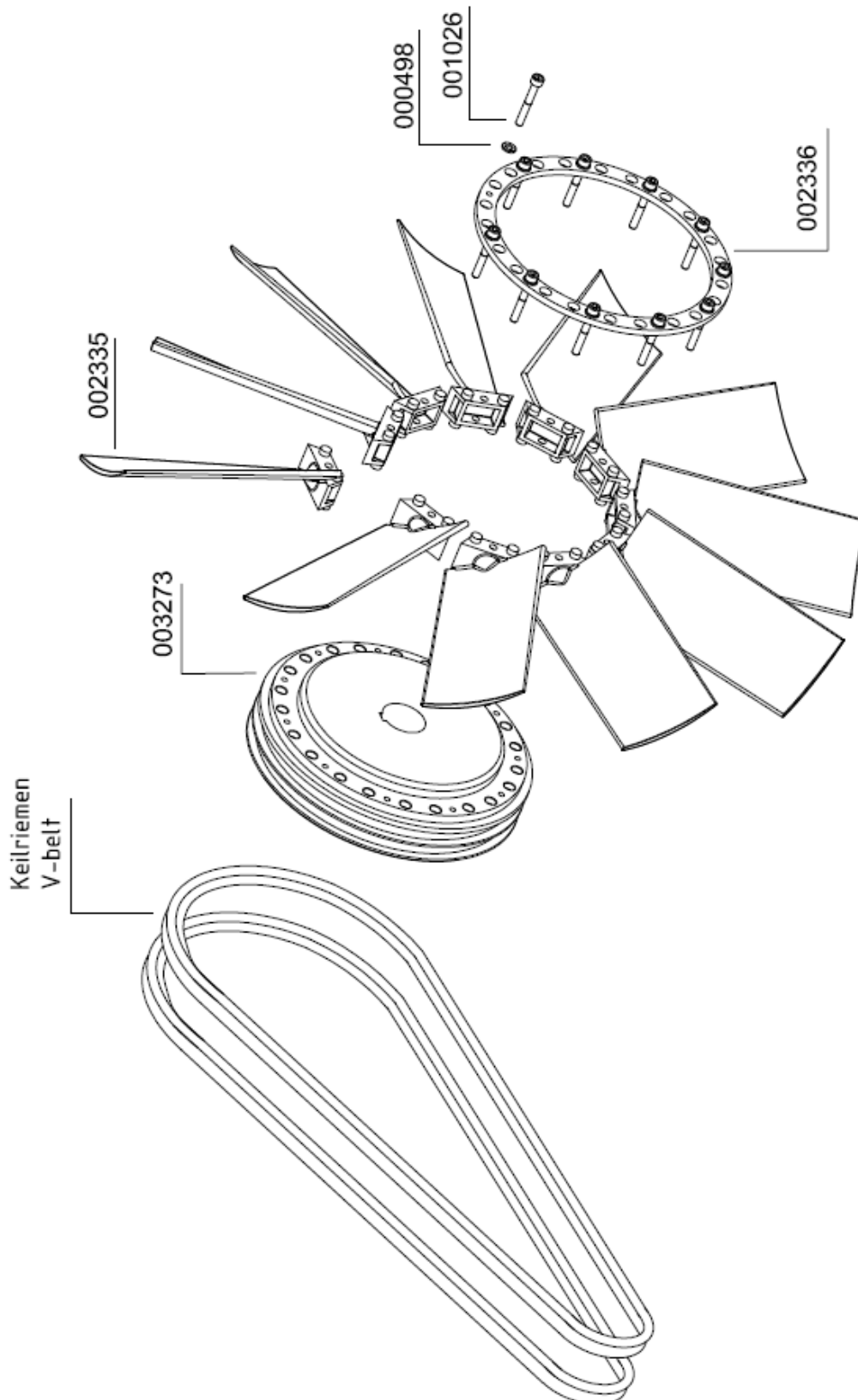

C



ERSATZTEILLISTE / SPARE PART LIST

Baugruppe: E-Motor / Assembly: E-Motor

Best.-Nr. / Order No.	Benennung	Description
000148	Keilriemen	V-Belt
001118	Schlossschraube	Carriage Screw
001164	Stopfmutter	Lock Nut M10
001187	U-Scheibe A10	Washer A10
001209	Passfeder	Woodruff Key
001685	Keilriemen	V-Belt
003694	Keilriemen	V-Belt
003924	Keilriemenscheibe	V-belt pulley
004017	Keilriemenscheibe Alu	V-belt pulley alloy
006197	Riemenscheibe	Pulley c/w bushing
007101	Keilriemenscheibe inkl. Spannbuchse	V-belt pulley for motor 7.5 kW
007443	Keilriemenscheibe 2-rilling SPA, Alu	V-belt pulley alloy
011193	Antriebsmotor 7,5 kW / 400 V - 50/60 Hz	Motor 7,5kW, 400V, 50-60Hz
011723	Antriebsmotor 5,5kW 400 V	Drive motor 5,5 kW 400V
011801	Antriebsmotor 7,5kW / 230V / 50/60 Hz	Motor, 7,5kW, 230V, 50-60 Hz
011802	Antriebsmotor 5,5kW 230V	Drive motor 5,5 kW 230V

C

DETAILANSICHT / DETAILED VIEW

Baugruppe: E-Motor / Assembly: E-Motor

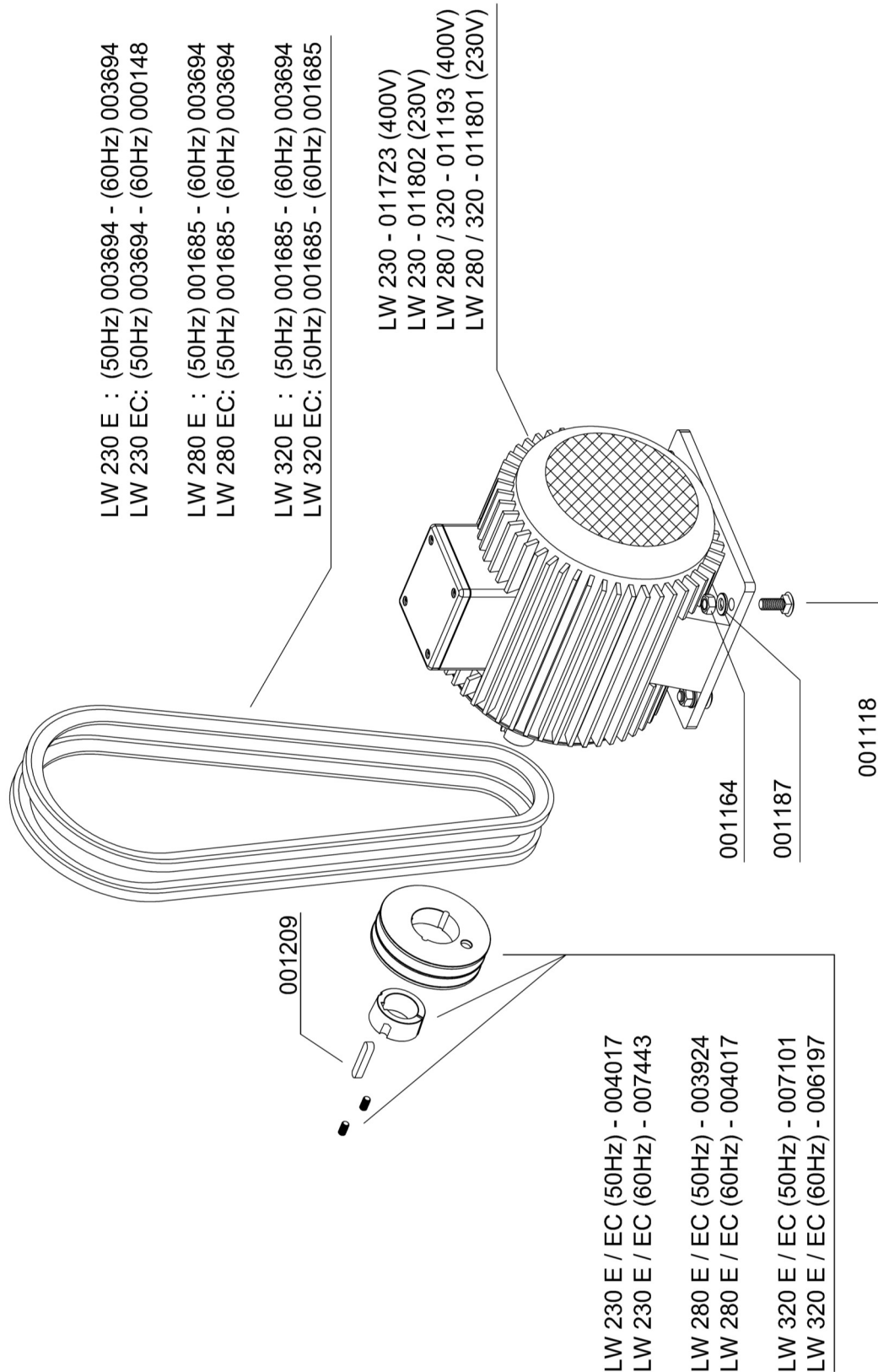

ERSATZTEILLISTE / SPARE PART LIST

Baugruppe: Saug und Druckventil 1. Stufe /

Assembly: In and outlet valve 1st stage

Best.-Nr. / Order No.	Benennung	Description
002093	Saug-und Druckventil, 1. Stufe	In & Outlet Valve 1st Stage

C

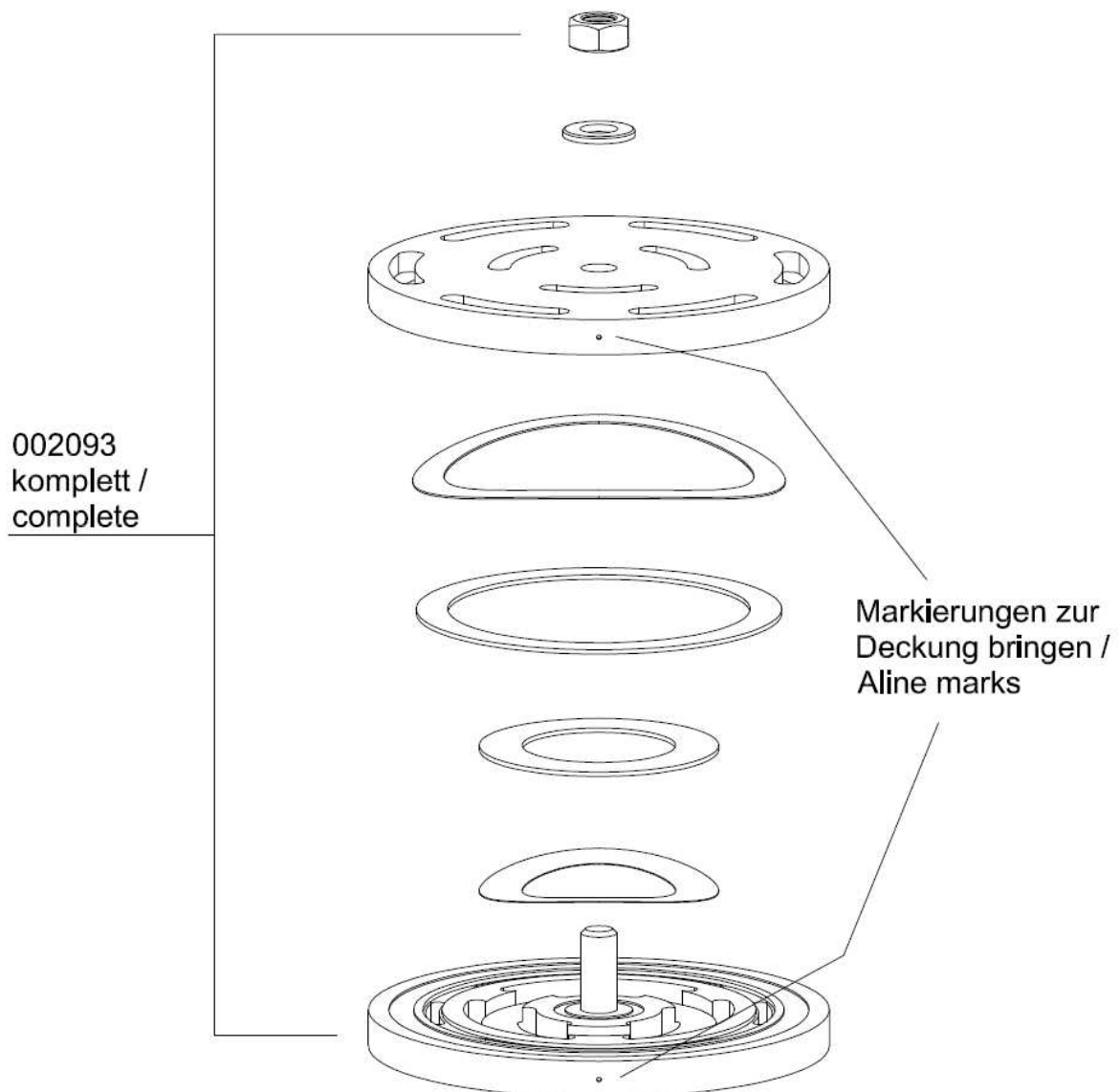

ERSATZTEILLISTE / SPARE PART LIST

Baugruppe: Saug und Druckventile 2. und 3. Stufe /

Assembly: In and outlet valves 2nd and 3rd stage

Best.-Nr. / Order No.	Benennung	Description
000528	Ventildichtung, Saug- & Druckventil unten	Lower Valve Gasket, 3rd St.
000529	Ventildichtung, Saug- & Druckventil unten	Lower Valve Gasket, 2nd St.
000541	Dichtring / Dichtung Ventil	Upper Alloy Seal Ring
000542	Saug- & Druckventil, 2. Stufe komplett	In- & Outlet Valve, 2nd Stage
000543	Saug-Druckventil, 3. Stufe	In- & Outlet Valve, 3rd Stage

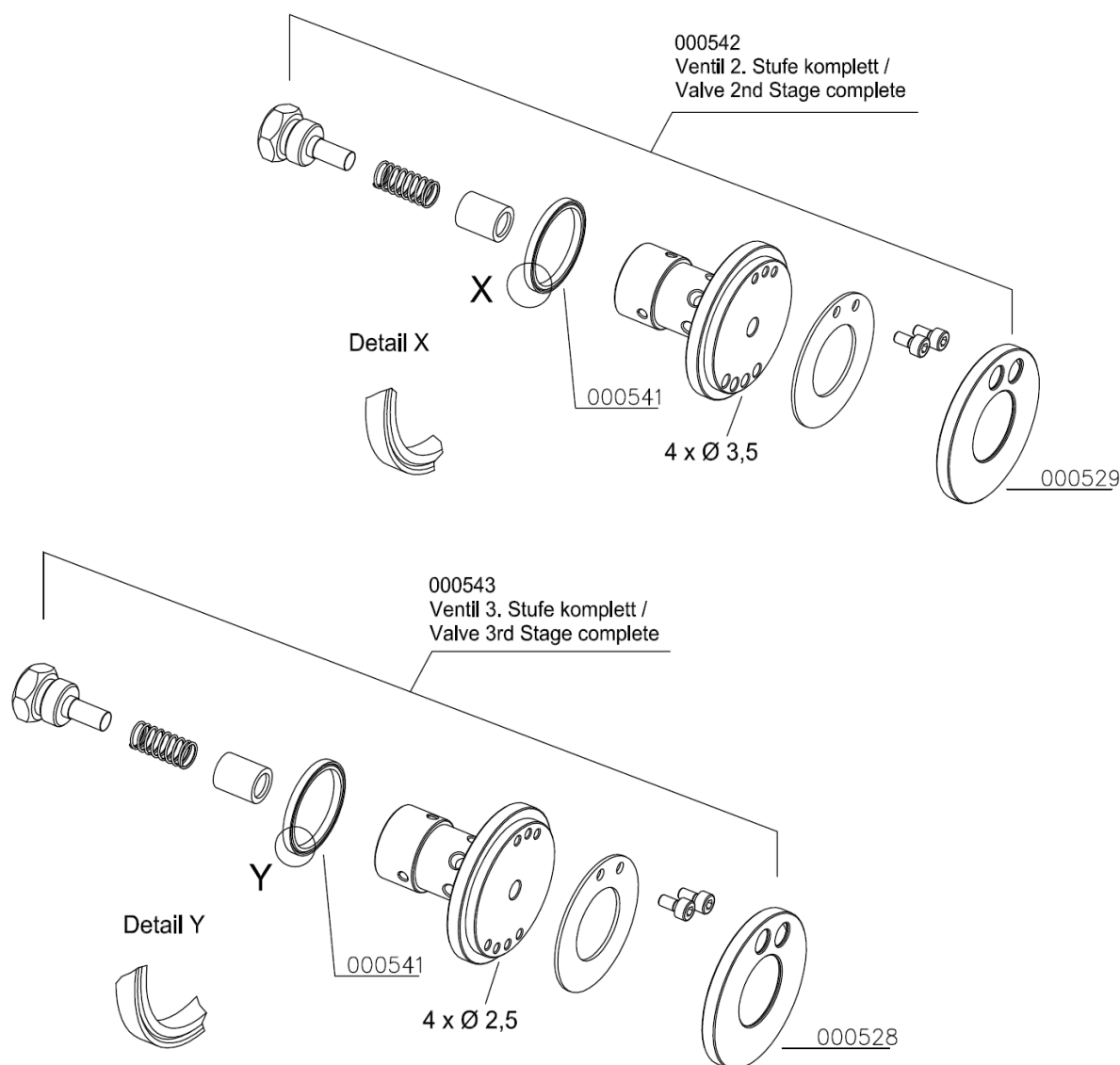



ERSATZTEILLISTE / SPARE PART LIST

Baugruppe: Ölablassschlauch / Assembly: Oil Drainage Tube

Best.-Nr. / Order No.	Benennung	Description
000817	Verschraubung	Connection
001005	Zylinderschraube	Allen Screw
002153	Ölablassschlauch	Oil drain hose
006964	Klemmhalter Ölablassschlauch	Clamp Oil Drain Hose

C

DETAILANSICHT / DETAILED VIEW

Baugruppe: Ölablassschlauch / Assembly: Oil Drainage Tube

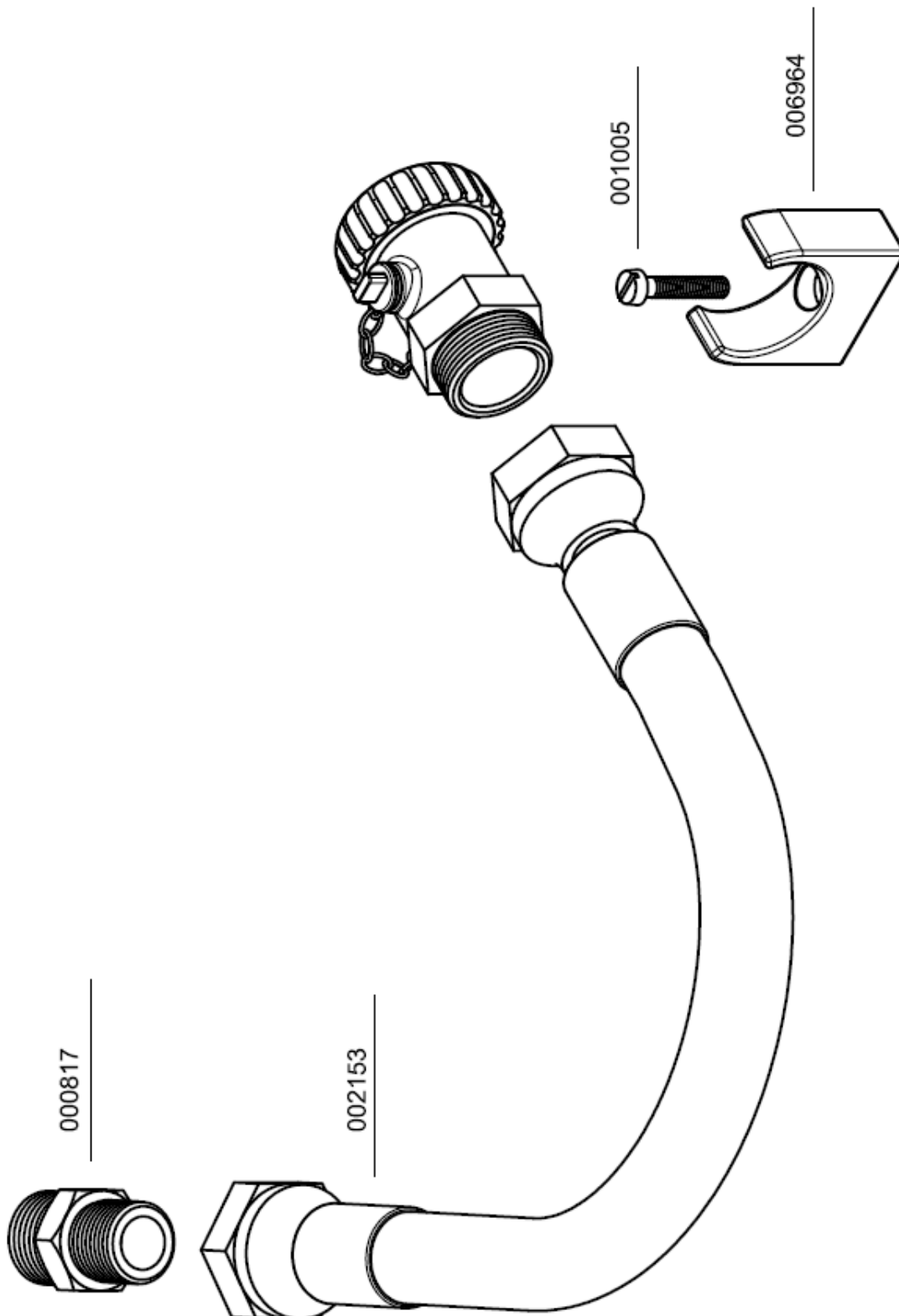

C



ERSATZTEILLISTE / SPARE PART LIST

Baugruppe: Verteilerleiste mit Füllschlauch

Assembly: Distributor Block c/w Filling Hose

Best.-Nr. / Order No.	Benennung	Description
000761	Verschraubung	Elbow Connection
000783	Verschraubung	Straight Connection
000838	Verschlussstopfen	Plug
001004	Zylinderschraube	Allen Screw
002811	Hochdruckschlauch	HP-Hose
007523	Verteilerleiste, Alu, gold	Distributor Block, alloy, gold

C

DETAILANSICHT / DETAILED VIEW

Baugruppe: Verteilerleiste mit Füllschlauch

Assembly: Distributor Block c/w Filling Hose

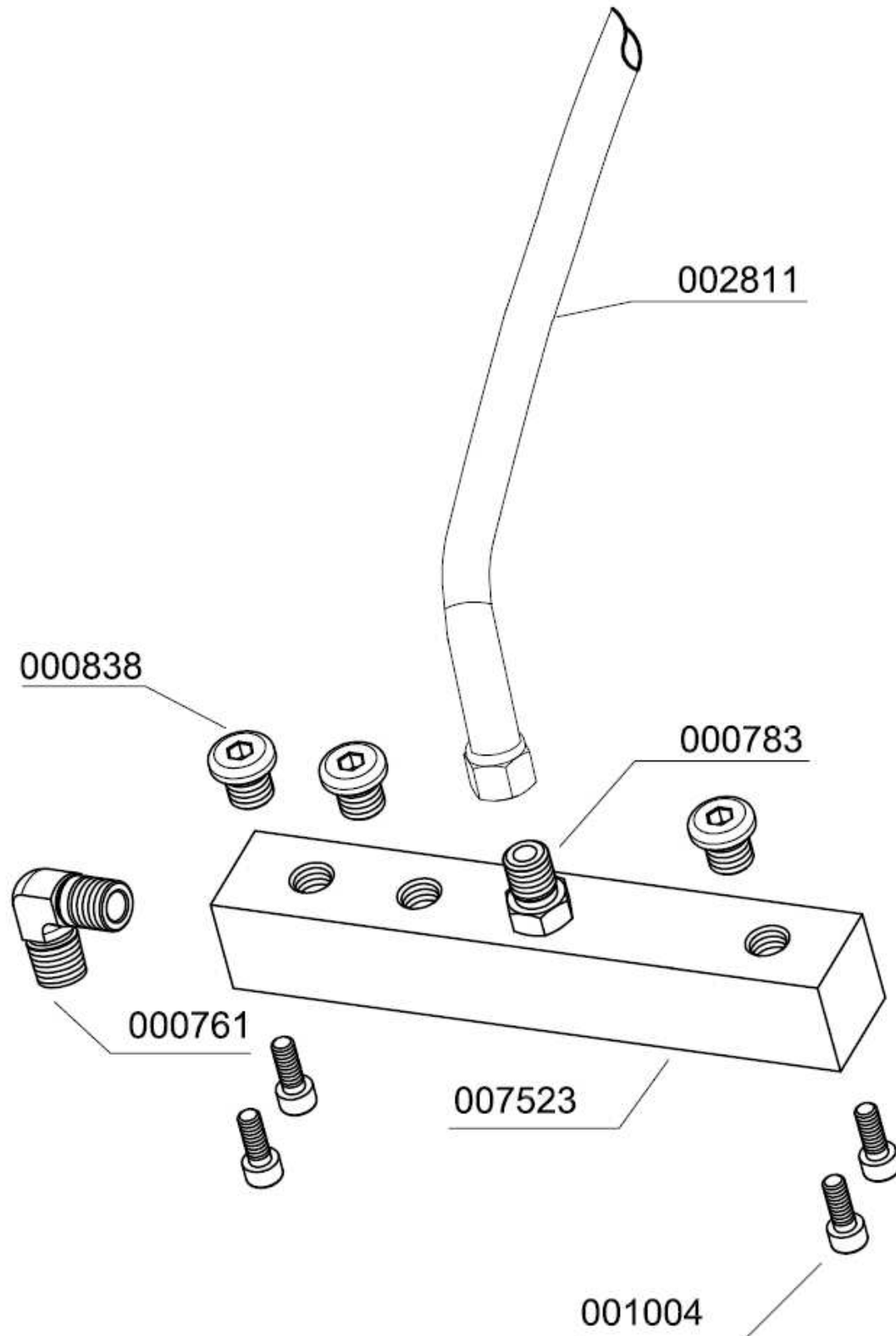

C



ERSATZTEILLISTE / SPARE PART LIST

Baugruppe: Kreuzventil / Assembly: Cross Design Valve

Best.-Nr. / Order No.	Benennung	Description
000213	Handrad, schwarz DIN 200bar	Hand Wheel DIN 200 bar, black
000215	Handrad rot DIN 300bar	Hand Wheel DIN 300 bar, red
000386	Gleitscheibe, Kreuzventil	Slide Washer
000387	Feder (Kreuzventil)	Coil Spring, cross d. valve
000665	Manometer Messing	Pressure Gauge, brass
000666	Manometerschutzkappe Ø63mm	Protector Pressure Gauge Ø63mm
000696	Füllanschluss o. Handrad 200bar	Filling Connector w/o handwheel 200bar
000698	Füllanschluss o. Handrad 300bar	Filling Connector w/o handwheel 300bar
000709	Füllventil Kreuzbauweise, kompl.	Filling Valve cross design
001237	O-Ring DIN Flaschenanschluss	O-Ring DIN filling connector
001391	O-Ring	O-Ring
001392	Füllhandrad Kreuzventil	Hand Wheel Filling Valve cross
001393	Entlüftungsspindel	Vent Spindle
001394	Entlüftungshandrad	Vent Hand Wheel
001395	Gleitscheibe, schwarz, Kreuzventil	Slide Washer, plastic black
001397	Kupferdichtung	Copper Seal Ring
001398	Madenschraube	Worm Screw
001399	Oberspindel	Adapter Shaft
001400	Dichtspindel, Kreuzventil	Seal Spindle Filling Valve
001401	Schlitzmutter	Slotted Nut
001402	Gehäuseverschraubung komplett mit O-Ringen	Filling Spindle Body c/w O-Rings
002812	Verschraubung, Edelstahl	Connection, S/S
003687	Füllventil Kreuzbauweise komplett 200bar	Filling Valve cross complete unit 200bar
003688	Füllventil Kreuzbauweise komplett 300bar	Filling Valve cross complete unit 300bar

C

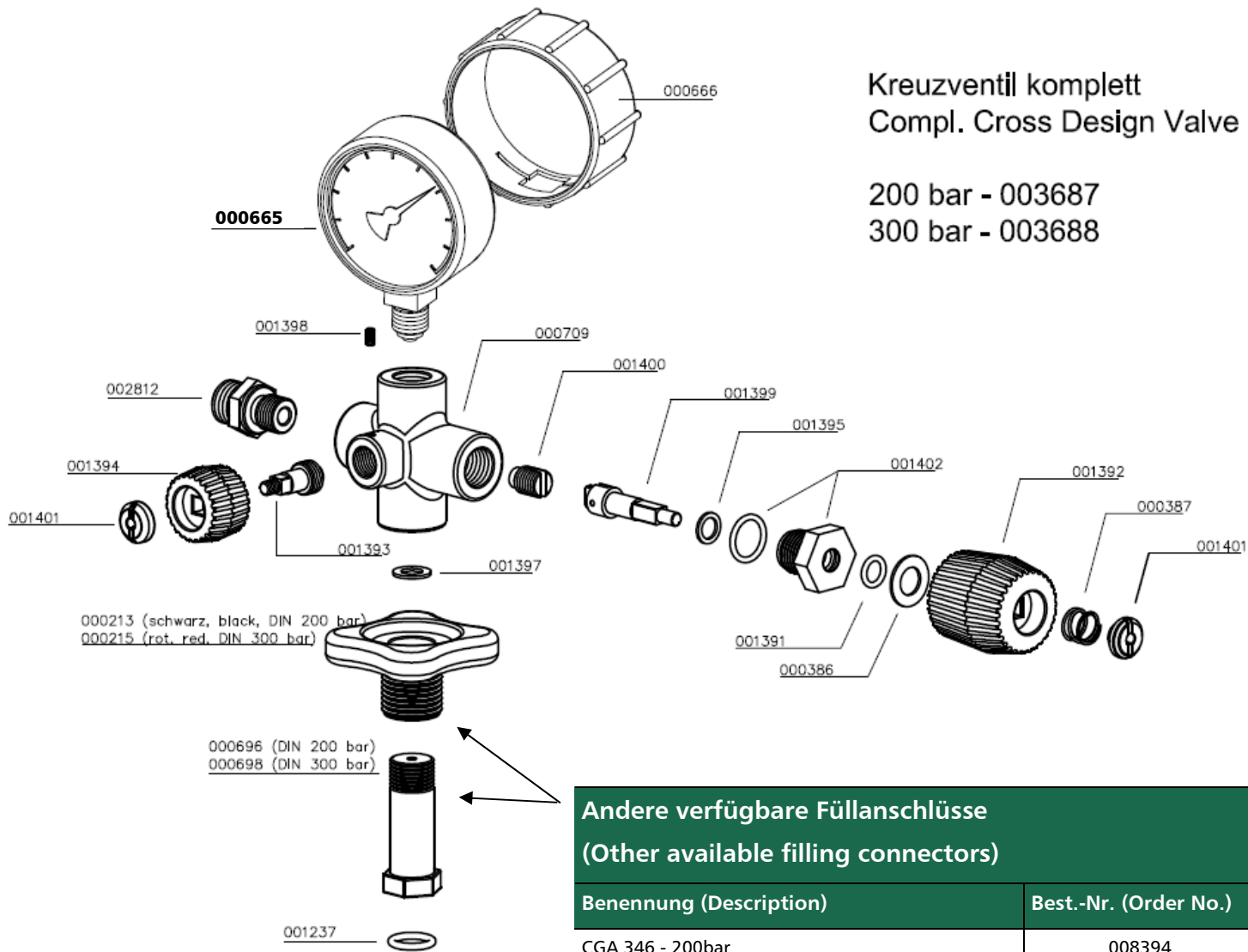

Kreuzventil komplett
Compl. Cross Design Valve

200 bar - 003687
300 bar - 003688

Andere verfügbare Füllanschlüsse (Other available filling connectors)	
Benennung (Description)	Best.-Nr. (Order No.)
CGA 346 - 200bar	008394
CGA 347 - 300bar	006842
INT / Yoke - 200/232 bar	002307

DETAILANSICHT / DETAILED VIEW

Baugruppe: Kreuzventil / Assembly: Cross Design Valve





OPTIONS



Inhaltsverzeichnis

Auto Shut Down.....	1
Automatic Condensation Drain - Microsoft Publisher.....	6
Auto Start Function.....	17
Oil Pressure Gauge	22
Oil Pressure Monitoring	25
Oil Temperature Monitoring	29
Cylinder Head Temperature Monitoring	32
Interstage Pressure Gauge	35
200+300bar Parallel Filling Pressure Operation.....	39
Air Cooler Connection Kit.....	43
Condensate Tank 60L	46



AUTO SHUT DOWN

D

AUTO SHUT DOWN

Final pressure switch

The pressure switch shuts off the compressor automatically when the selected final pressure is reached. The final pressure switch is already adjusted to the corresponding cut-out pressure.

The pressure can be adjusted with the upper adjusting screw as follows:

Increasing cut-out pressure:

Turn the adjusting screw clockwise

Reducing cut-out pressure:

Turn the adjusting screw anti-clockwise

Adjust the pressure switch in steps of a quarter turn.

Restart the compressor after every adjustment step to verify the actual cut-out pressure.

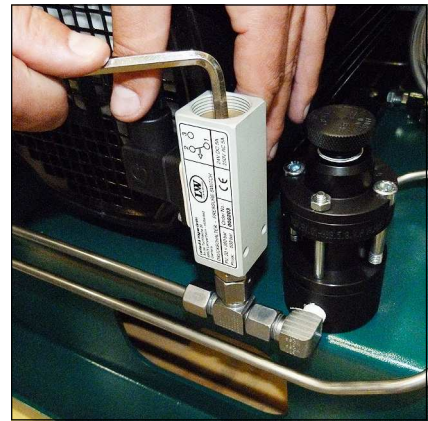

Final pressure switch

D



Note

Do not adjust the final pressure switch to the safety valve pressure. The final pressure switch has to be adjusted to min. 10 bar below the safety valve pressure. Otherwise, the safety valve can open during operation. This considerably reduces the life of the safety valve.

Example settings:

Safety valve	Max. Operating Pressure
225 bar	215 bar
250 bar	240 bar
330 bar	320 bar

AUTO SHUT DOWN

Safety valve test



Note

Do not fill any tank during test phase!

Safety valve test as follows:

- Disconnect compressor from the electrical power supply and protect against unexpected restart.
- Remove the cover of the switch box.
- Switch on the "Test Safety Valve" switch (pressure switch will be deactivated!).
- Mount the cover of the switch box.
- Connect the compressor to the electrical power supply.
- Close filling valves.
- Start the compressor.
- Watch the final pressure gauge. The safety valve should open when reaching working pressure of the compressor. If not, switch off the unit and take out of service until the safety valve has been replaced.
- Switch off the compressor (compressor vented).
- Disconnect the compressor from the electrical power supply and protect against unexpected restart.
- Remove the cover of the switch box.
- Switch off the "Test Safety Valve" switch (pressure switch will be activated!).
- Mount the cover of the switch box.
- Connect the compressor to the electrical power supply.

The safety valve test is now completed.

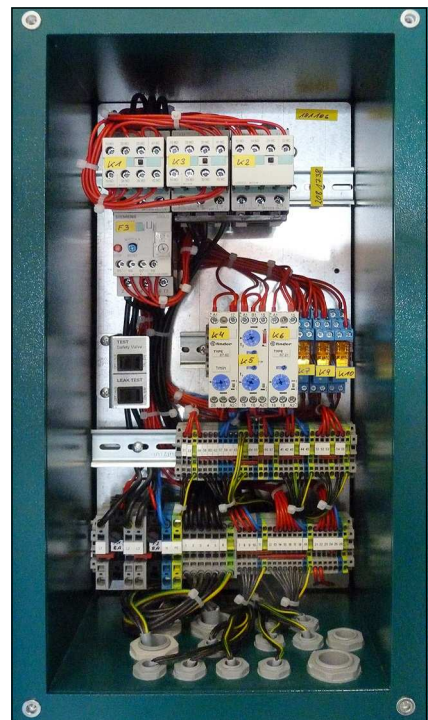

Switch box



Safety valve test switch (up)

AUTO SHUT DOWN

Druckschalter / Pressure Switch

Best.-Nr. / Order No.	Benennung	Description
000203	Druckschalter 50-350 bar	Pressure Switch 50-350 bar
000749	Verschraubung, mit fester Mutter	Connection with fixed nut
000764	Winkelverschraubung	Elbow connection

000203

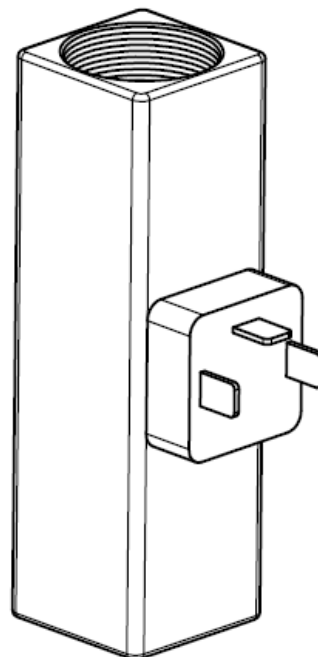

000749

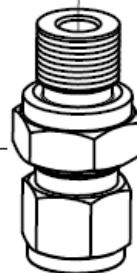

000764

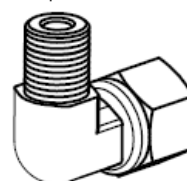

D

AUTO SHUT DOWN

Sicherheitsventil / Safety Valve

Best.-Nr. / Order No.	Benennung	Description
000751	T-Verschraubung 8L	T-connection 8L

The safety valve in option Auto-Stop is different to the standard one. A T-connection is installed at the outlet of the safety valve!

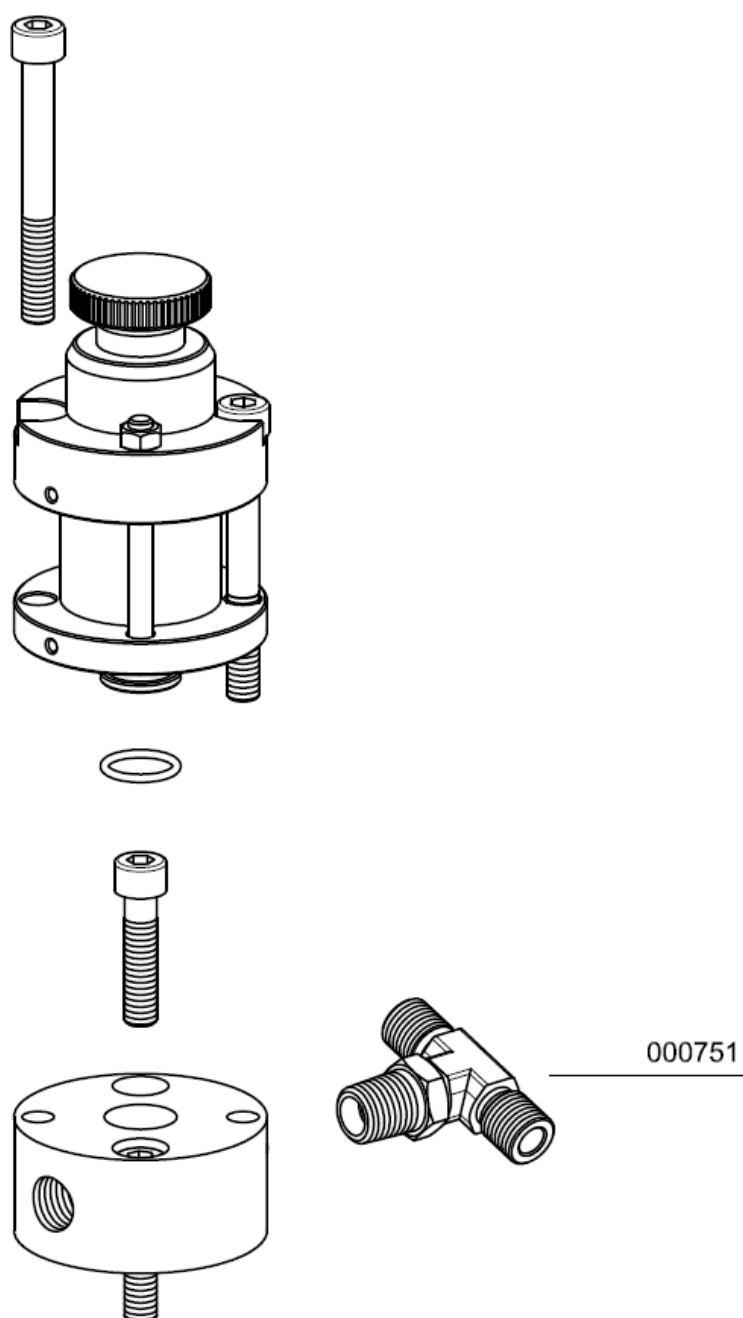

D



AUTOMATIC CONDENSATION DRAIN

D

AUTOMATIC CONDENSATION DRAIN

Automatic condensation dump system



Note

The collected condensate can contain oil and has to be disposed according to regulations.

The LW 230-280-320 E Compact comes as standard with an automatic condensation dump system. Solenoids drain all condensate separators every 15 minutes.

To test the system, press the blue condensate test drain button on the operating panel.

Oil / water separators

Condensate is separated after every stage of compression. All three oil / water separators are equipped with electronic timer controlled solenoids. The timer is located in the switch box and activates the dump valves about every 15 minutes.

To release the complete condensate through the black plastic hoses, we recommend using an 20 l container at least.

The drain noise can be kept to a minimum by using a silencer.

Maintenance intervals

We recommend to clean oil and water separators every 500 operating hours or at least once a year, to check for corrosion damage and to replace o-rings if necessary.

All oil / water separators have an integrated sinter filter which has to be replaced every 1,000 operating hours.

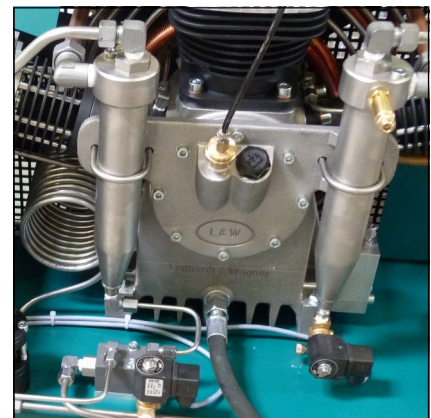

Öl- / Wasserabscheider 1. und 2. Stufe



Oil / water separators final stage

AUTOMATIC CONDENSATION DRAIN

Leak test



Note

Do not fill any tank during test phase!

Leak test as follows:

- Disconnect the compressor from the electrical power supply and protect against unexpected restart.
- Remove the cover of the switch box.
- Switch on the leak test switch (solenoid valves will be deactivated!).
- Mount the cover of the switch box.
- Connect the compressor to the electrical power supply.
- Close filling valves.
- Start the compressor.
- Switch off the compressor at a pressure of approx. 150 bar.
- Verify the compressor for release noises. (A slight hiss of the air inlet filter nozzle can be ignored). If release noises occur, localise blow off position(s).
- Switch off the compressor.
- Disconnect the compressor from the electrical power supply and protect against unexpected restart.
- Remove the cover of the switch box.
- Switch off the leak test switch (solenoids will be activated!).
- Mount the cover of the switch box.
- Connect the compressor to the electrical power supply (compressor vented).

The leak test is now completed.



Switch box

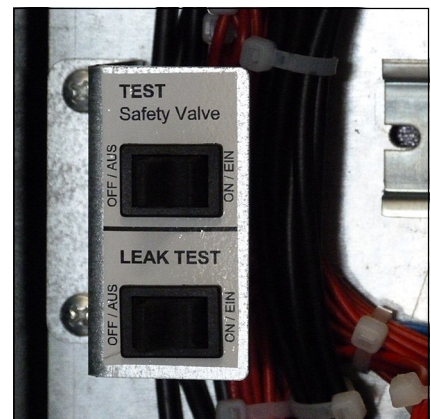

Leak test switch (lower)

AUTOMATIC CONDENSATION DRAIN

Oil / water separators final stage - maintenance



Note

Clean all parts thoroughly before assembly.

Change/clean oil / water separators final stage as follows:

- Loosen pipe connections and mounting screws.
- Remove oil / water separators.
- Open ring nut and remove separator top (Fig. 1).
- Loosen nut at the separator top.
- Change sinter filter (Fig. 2).
- Reassemble all parts and tighten nut.
- Change o-ring, previously grease new o-ring (Fig. 3).
- Place separator top and tighten ring nut manually.
- Replace silencer.
- Mount oil / water separators.
- Tighten pipe connections and mounting screws.

The oil / water separator maintenance is now completed.



Oil / water separators final stage



Fig. 1 - Loosen ring nut

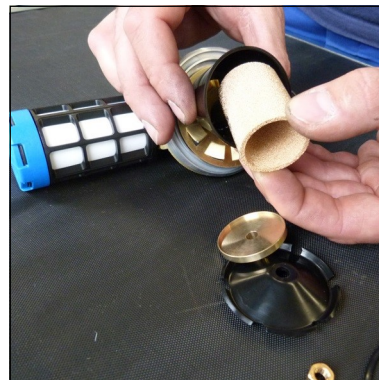

Fig. 2 - Change sinter filter



Fig. 3 - Change o-ring

AUTOMATIC CONDENSATION DRAIN

Pneumatic condensate valve - maintenance



Note

Clean all parts thoroughly before assembly.

Pneumatic condensate valve change as follows:

- Loosen pipe connections and mounting screws.
- Remove pneumatic condensate valve.
- Loosen connection (Fig. 2).
- Change sinter filter (Fig. 3).
- Tighten horizontal screw.
- Mount pneumatic condensate valve.
- Tighten pipe connections and mounting screws.

Pneumatic condensate valve maintenance is now completed.

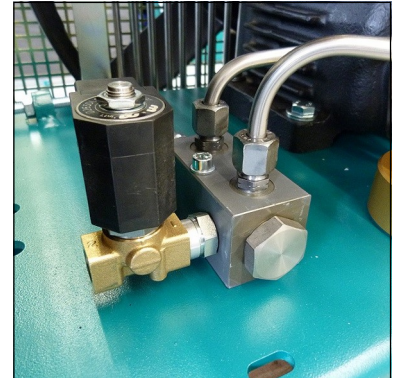

Pneumatic Condensate Valve

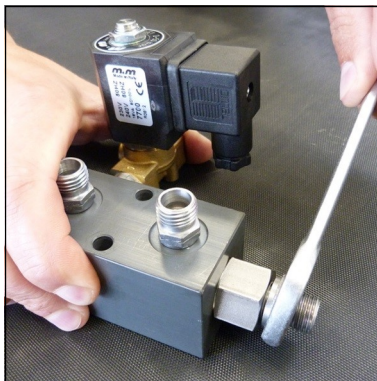

Fig. 2 - Loosen connection

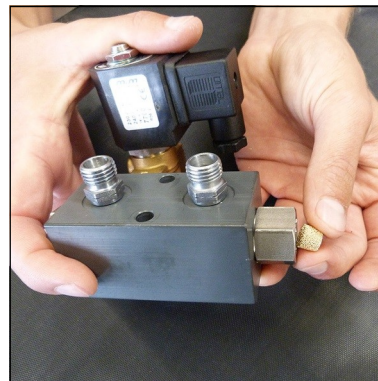

Fig. 3 - Change sinter filter



AUTOMATIC CONDENSATION DRAIN

Öl- / Wasserabscheider Endstufe / Oil- / Water Separator Final Stage

Best.-Nr. / Order No.	Benennung	Description
000175	Deckel, Wasserabscheider	Cap
000178	Schalldämpfer G1/2"	Silencer G1/2"
000182	Endstufe Wasserabscheider (PN 15 bar)	Water Separator c/W bracket
000183	Wasserabweiser	Filter Protecor
000184	Sinterfilter Wasserabscheider	Siltered Filter, Oil Filter
000185	Halteteller	Plate
000186	Drallscheibe	Twist Disk
000395	Blechhalter Kondensatabscheider	Bracket water separator
000497	Mutter M6	Nut M6
000498	Unterlegscheibe	Washer A6
000761	Verschraubung WE 08 PLR CFX	Connection
000765	Schneidring PSR 08 LX	<i>Olive Seal 8mm</i>
000766	Mutter 8L	Nut 8L
000921	Reduzierung 1/2"-1/4"	Reducer 1/2"-1/4"
000948	Flachkopfschraube M6x16mm DIN6912 8.8 ZN	Pan Head Bolt M6x16mm DIN6912 8.8 ZN
001027	Zylinderschraube M6x30	Allen Bolt M6x30
001156	Stopfmutter M6 DIN985 ZN	Lock Nut M6
001294	O-Ring 68x3 NBR90	O-Ring 68x3
001431	Befestigungsring Wasserabscheider LW 450	Lock Ring Water Separator
002409	Winkelschnellkupplung G1/8"-8mm	Quick release coupling elbow
002466	Kondensatbehälter für Abscheider	Condensate bowl
002563	Wasserabscheider Oberteil PN 15 bar	Water Separator, upper comp. PN15 bar

D

AUTOMATIC CONDENSATION DRAIN

Öl- / Wasserabscheider Endstufe / Oil- / Water Separator Final Stage

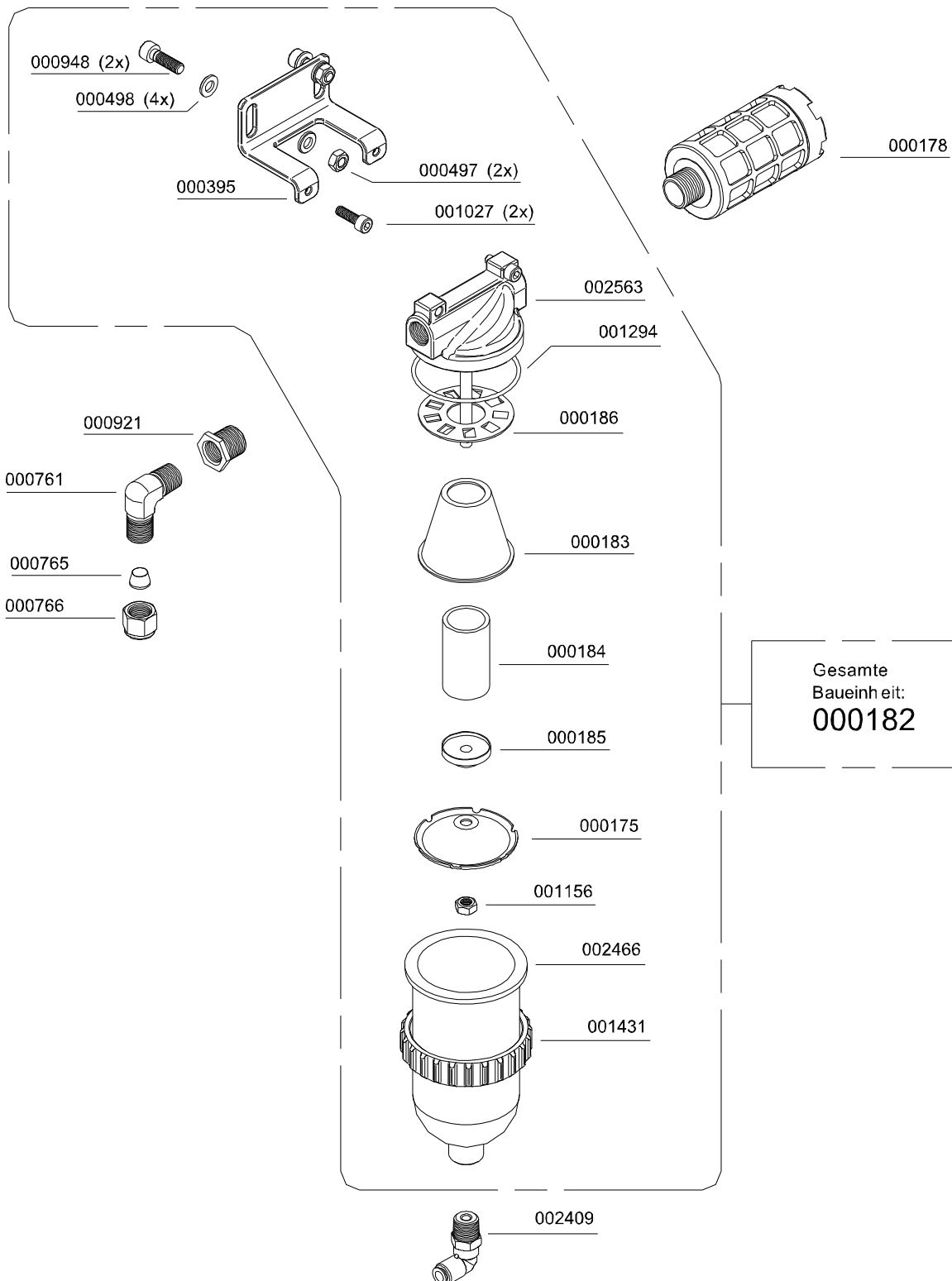

D



AUTOMATIC CONDENSATION DRAIN

Pneum. Kondensat-Ablassventil / Pneumatic Condensate Valve

Best.-Nr. / Order No.	Benennung	Description
000188	Sinterfilter	Sintered Filter
000190	O-Ring, 10 x 2,5 NBR90	O-Ring, 10 x 2,5 NBR90
000191	Steuerkolben	Piston
000498	U-Scheibe A6	Washer A6
000721	Verschraubung	Connection
000732	Mutter	Union Nut 06L
000733	Schneidring	Olive Seal SR 06 (Ø 6mm)
001011	Zylinderschraube	Allen Bolt
001494	Mutter 08L, Edelstahl	Union Nut 08L, S/S
001495	Schneidring 8mm, Edelstahl	Oilve Seal 8mm, S/S
006614	O-Ring, 20 x 2 NBR90	O-Ring, 20 x 2 NBR90
007778	Verschraubung, Edelstahl	Elbow Connection, S/S
011064	Pneum. Kondensatablaßventil	Pneumatic Condensate Valve
011065	Gehäuse, pneum. Kondensatventil	Housing PCV
011066	Düsenschraube	Inlet Jet Screw
011072	Verschlussstopfen für 011064	Plug for 011064
011559	Reparatursatz pneum. Kondensatventil	Repair Kit Condensate Valve

D

AUTOMATIC CONDENSATION DRAIN

Pneum. Kondensat-Ablassventil / Pneumatic Condensate Valve

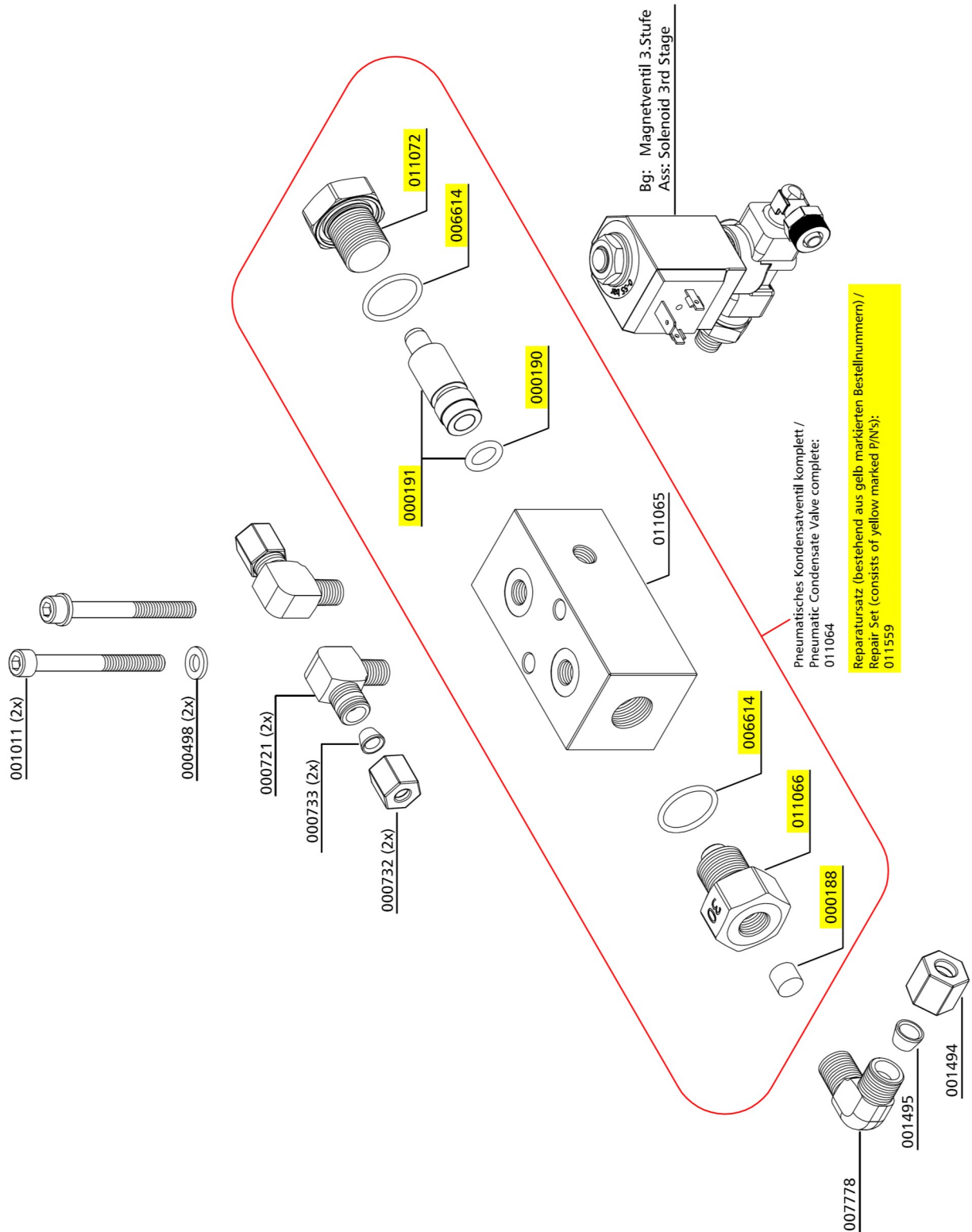

D

AUTOMATIC CONDENSATION DRAIN

Baugruppe: Magnetventil / Assembly: Solenoid

Best.-Nr. / Order No.	Benennung	Description
000892	Doppelnippel	Double Nipple
001546	Aludichtring für Magnetventile G1/4"	Alloy Seal Ring for G1/4"
005855	Winkelschraubverschraubung 8 mm	Elbow Hose Connection 8 mm
006113	Magnetventil 0-55 bar	Solenoid 0-55 bar

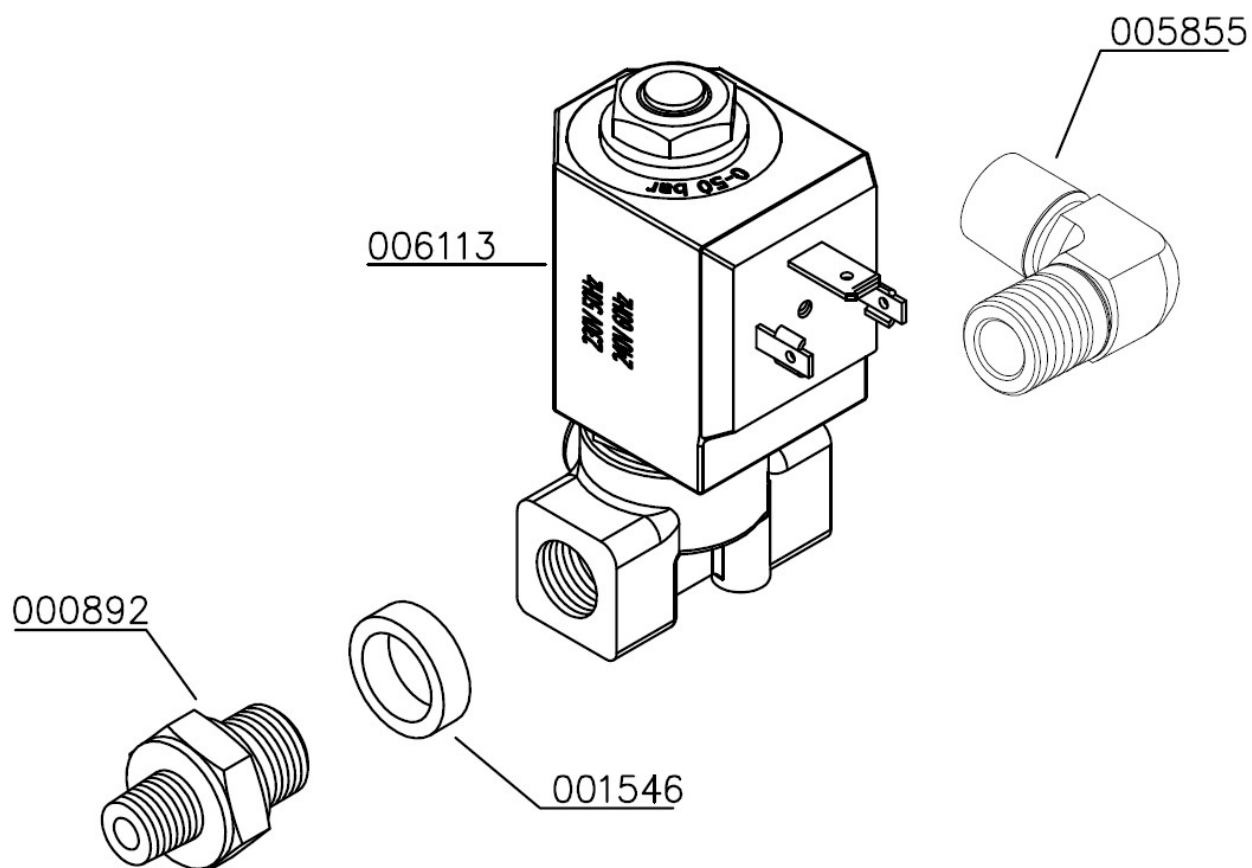

D

AUTOMATIC CONDENSATION DRAIN

Switch box with condensate drain test switch

Best.-Nr. / Order No.	Benennung	Description
002089	Betriebsstundenzähler	Hour counter
002502	Kondensat Test Schalter	Drain test switch
002942	START/STOP Schalter mit LED	Start/Stop switch c/w LED
003121	NOT-AUS Schalter	Emergency switch
004704	Warnlampe	Warning Lamp
005670	Einlegeschild Kondensat Test	Label Drain Test
006859	Schildträger	Label holder
006925	Einlegeschild Motorschutz	Label Motor protect

D





AUTO START FUNCTION

D

AUTO START FUNCTION

Auto Start Function

The auto start function allows operating the compressor optionally in automatic or semi-automatic mode by turning the selector switch.

Semi-automatic operation:

Start the compressor by pushing the Start button. The compressor automatically shuts off when final pressure is reached. To restart the compressor, push the Start button again. The unit can be shut down at any time during operation by pushing the Stop button.



Selector switch auto start function

Automatic operation:

Start the compressor only once by pushing the Start button. The Start button lights up and the unit automatically shuts off when final pressure is reached. If outlet pressure decreases below the selected minimum pressure, the unit automatically restarts.



Note

The compressor can not be manually started during automatic operation.

To enable a manual start, shut off automatic operation by pushing the Stop button (Start button lamp goes out). Now turn selector switch to semi-automatic mode and start the compressor with the Start button.

Adjust re-start pressure (minimum filling pressure)

The pressure switch for start pressure is located after the pressure maintaining valve. The pressure can be adjusted with the upper adjusting screw.

Increasing re-start pressure: turn adjusting screw clockwise

Reducing re-start pressure: turn adjusting screw anti-clockwise

Adjust pressure switch in steps of a quarter turn. Check settings after every adjustment step.

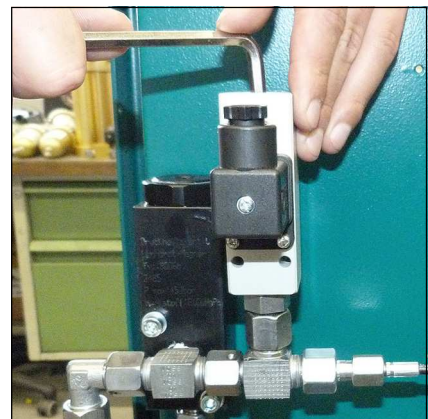

Adjust re-start pressure

AUTO START FUNCTION

Filling procedure semi-automatic operation



Caution! Only fill cylinders which:

- are marked with the test mark and the test stamp of the expert.
- have been hydro static tested (check last test date).
- are rated for the final pressure.
- are free from humidity.



Note

The unit shuts down when final pressure is reached. Thus, the unit always has to be restarted manually.

1. Turn selector switch to semi-automatic mode.
2. Close all filling valves.
3. Connect closed compressed air cylinders.
4. Open filling valves.
5. Start compressor by pushing the ON button.
6. When filling pressure gauge increases, open filling valves slowly.
7. Fill compressed air cylinders to the desired pressure, subsequently close filling valves slowly.
8. Close and vent all filling valves.
9. Disconnect all compressed air cylinders from filling valves.

AUTO START FUNCTION

Filling procedure automatic operation

**Caution! Only fill cylinders which:**

- are marked with the test mark and the test stamp of the expert.
- have been hydro static tested (check last test date).
- are rated for the final pressure.
- are free from humidity.

**Note**

The unit shuts down when final pressure is reached. Thus, the unit always has to be restarted manually.

1. Turn selector switch to automatic mode.
2. Close all filling valves.
3. Connect closed compressed air cylinders.
4. Open filling valves.
5. Start compressor by pushing the ON button.
6. When filling pressure gauge increases, open filling valves slowly.
7. Fill compressed air cylinders to the desired pressure, subsequently close filling valves slowly.
8. Close and vent all filling valves.
9. Disconnect all compressed air cylinders from filling valves.
10. If automatic operation is interrupted by:
 - pushing the OFF button
 - turning the selector switch
 - tripping the emergency shut-off switch
 - opening of the doors or the coverthe unit has to be restarted.

AUTO START FUNCTION

Spare part lists

Best.-Nr. / Order No.	Benennung	Description
000203	Druckschalter	Pressure Switch
000751	T-Verschraubung 8L	T-Piece 8L
000765	Schneidring 8L	Olive Seal 8L
000766	Schneidring 8L	Olive Seal 8L
004691	Wahlschalter	Selector switch
005663	Einlegeschild	Label
006859	Schildträger	Label holder

D

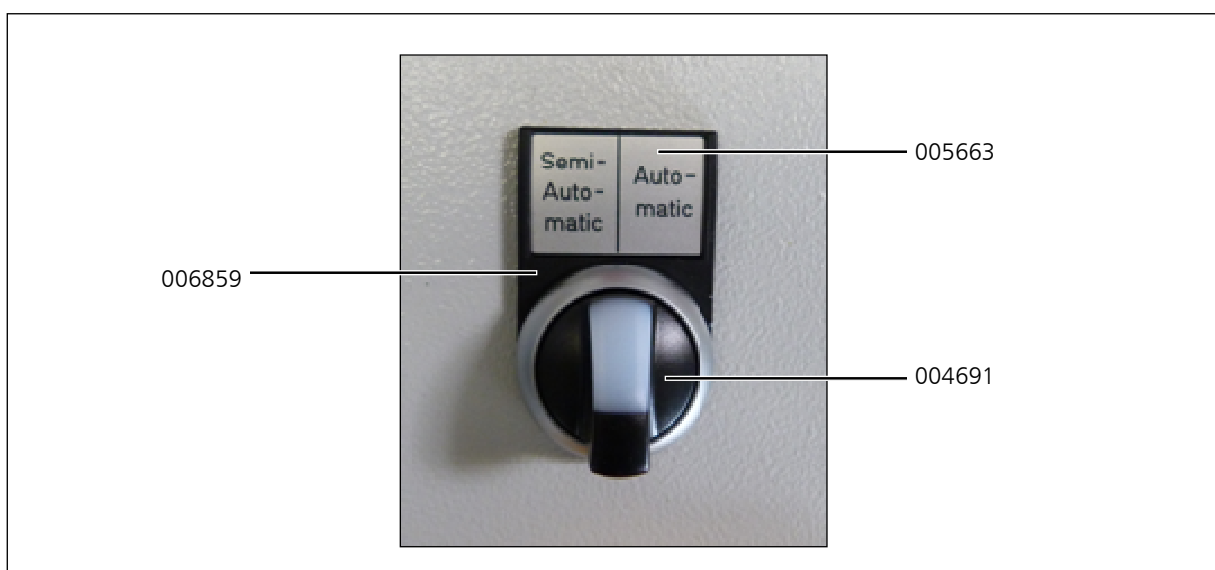
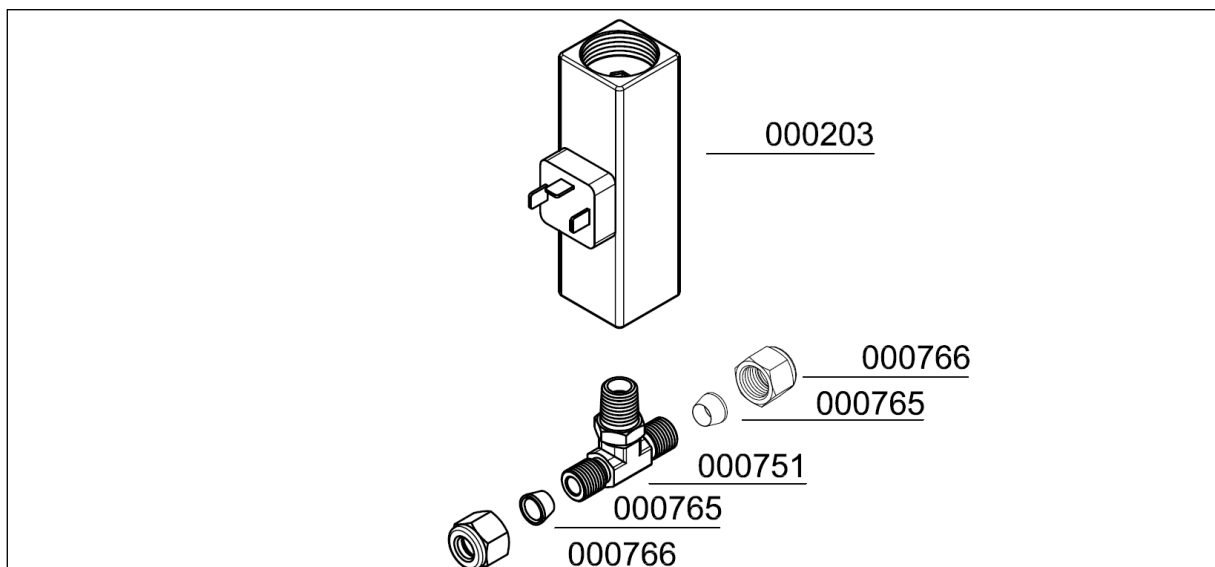



OIL PRESSURE GAUGE

D

OIL PRESSURE GAUGE

Oil pressure gauge

The oil pressure gauge shows the compressor oil pressure during operation. Oil pressure values should remain between:

- min. + 0.5 bar
- max. + 4.0 bar

If oil pressure value stays below the minimum value:

- Wrong compressor rotation direction (see rotation direction arrow)
- Oil level too low, not enough oil in the compressor
- Oil pump filter contaminated
- Oil intake pipe damaged / defective
- Oil temperature below +5 °C - lubrication not possible
- Oil temperature higher than +120 °C - oil viscosity too low
- Oil pump defective

If oil pressure value stays above the maximum value:

- Low oil temperature, between +5 °C and +10 °C
- Should stay within the range of tolerance when operation temperature is reached..



Oil pressure gauge

OIL PRESSURE GAUGE

Spare part lists

Best.-Nr. / Order No.	Benennung	Description
001447	Manometerschlauch 800mm	Hose for Pressure Gauge 800mm
002281	Winkelversch. mit fester Mutter	Elbow connection with fixed nut
002507	Öldruckmanometer 0-10 bar	Oil Pressure Gauge 0-10 bar

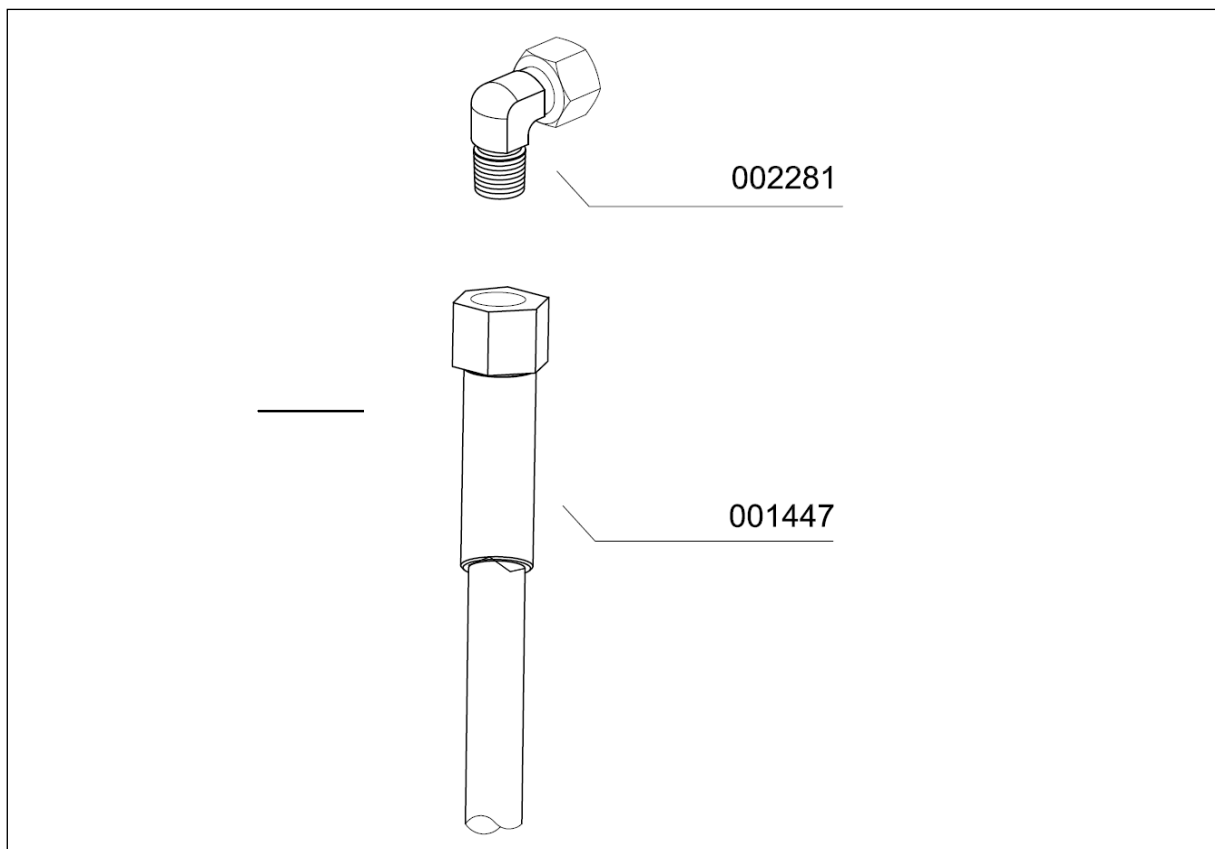
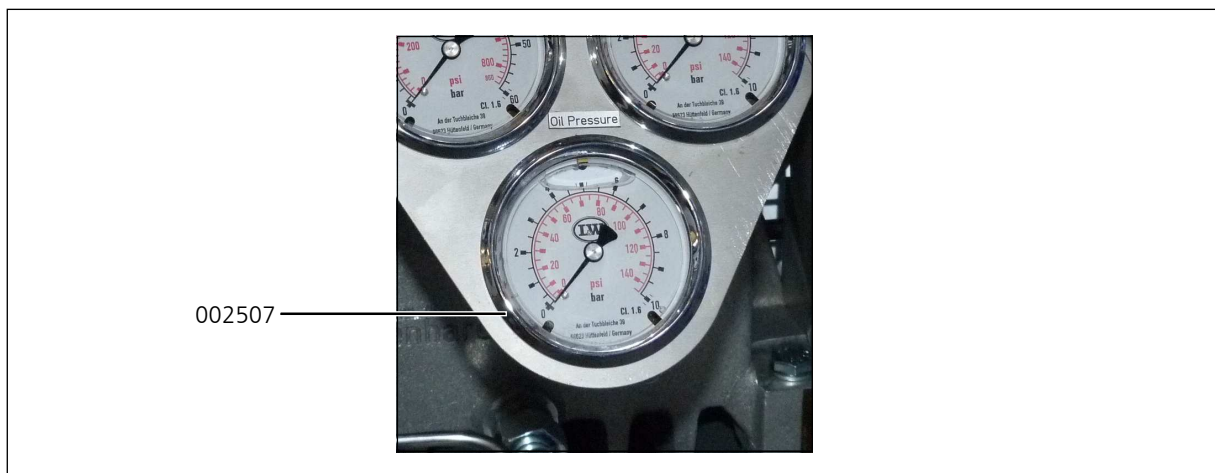



OIL PRESSURE MONITORING

D

OIL PRESSURE MONITORING

Oil pressure monitoring

The oil pressure is maintained by a pressure switch during operation. The compressor automatically shuts off when oil pressure decreases below the minimum pressure of +0.5 bar. The red warning lamp "Oil Pressure Monitoring" lights up.

Possible causes of fault:

- Wrong compressor rotation direction
(see rotation direction arrow)
- Oil level too low, not enough oil in the compressor
- Oil pump sieve contaminated
- Oil intake hose damaged / defective
- Oil temperature below +5 °C - lubrication not possible
- Oil temperature higher than +120 °C - oil viscosity too low
- Oil pump defective



Oil Pressure Monitoring



OIL PRESSURE MONITORING

Spare part lists

Best.-Nr. / Order No.	Benennung	Description
000722	Winkelverschraubung	Elbow Connection
004701	Warnlampe	Warning Lamp
004703	Schild	Label
004704	Relais für Warnlampe	Relais for warning lamp
005261	Öldruckschalter	Oil Pressure Switch
006631	Rohrleitung	Pipe
006859	Schildträger	Label holder

D

OIL PRESSURE MONITORING

Spare part lists

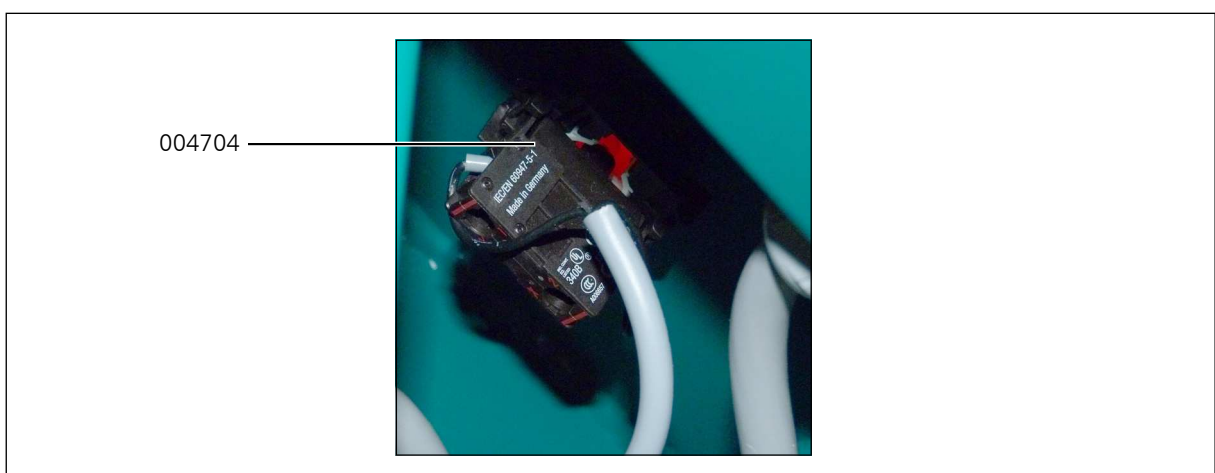
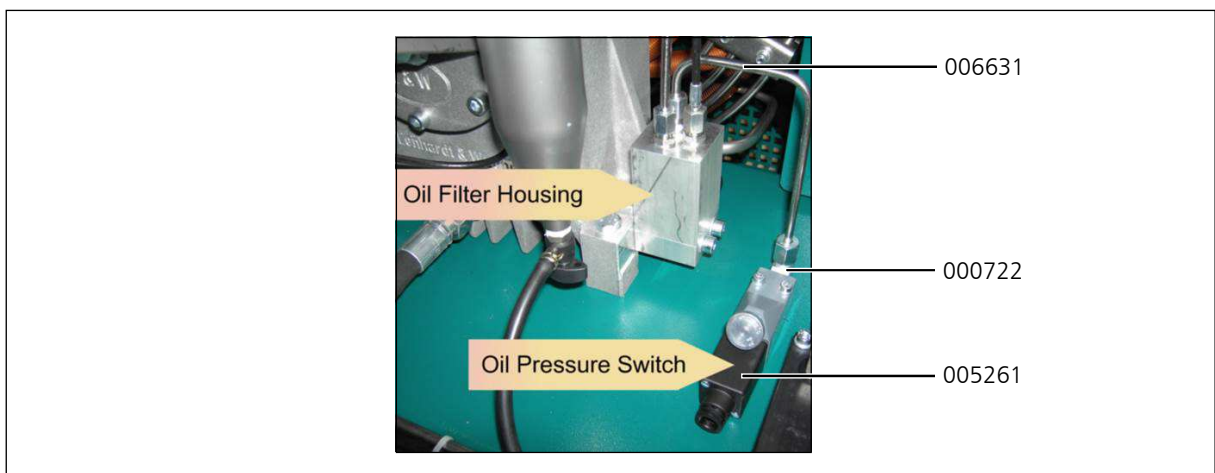

D



OIL TEMPERATURE MONITORING

D

OIL TEMPERATURE MONITORING

Oil temperature monitoring

Oil temperature monitoring

The oil temperature is maintained by a temperature sensor inside the compressor block during operation.

The compressor automatically shuts off when oil temperature exceeds the maximum pressure of +120 °C. The red warning lamp "Oil Temperature Monitoring" lights up.

Possible causes of fault:

- Ambient temperature too high
- Cooling air flow not sufficient
- Oil level too low
- Cooling pipes contaminated



Oil Temperature Monitoring



Warning

Risk of burns!

Allow the unit to cool before beginning troubleshooting.

OIL TEMPERATURE MONITORING

Spare part lists

Best.-Nr. / Order No.	Benennung	Description
004342	Display	Display
004730	Display und Sensor	Display and Sensor

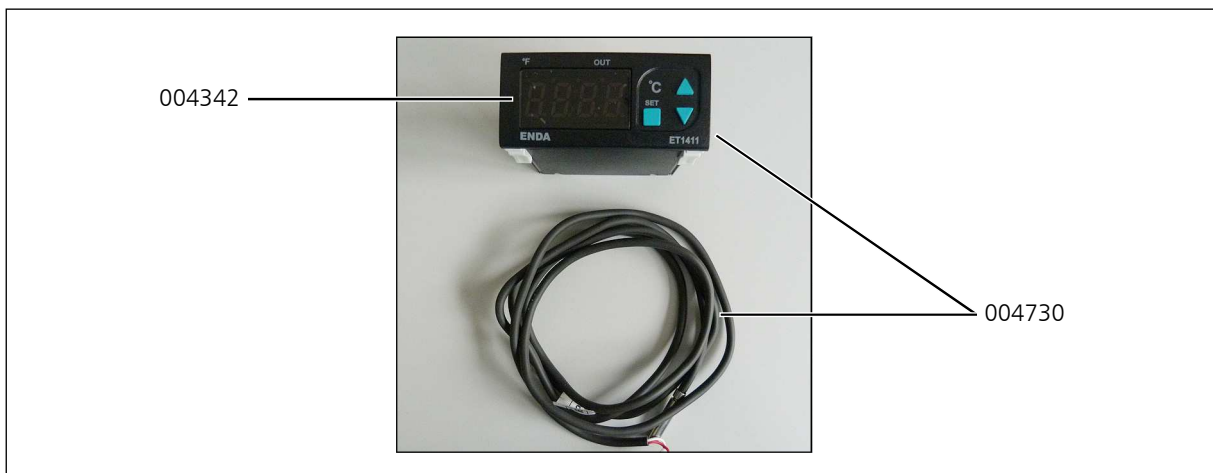

D



CYLINDER HEAD TEMPERATURE MONITORING

D

CYLINDER HEAD TEMPERATURE MONITORING

Cylinder head temperature monitoring

The cylinder head temperature is maintained by a temperature sensor at the cylinder head of the high pressure stage during operation. The compressor shuts off automatically when cylinder head temperature exceeds the maximum pressure of +160° C. The red warning lamp "Cylinder Head Temperature Monitoring" lights up.

Possible causes of fault:

- Ventilation of the compressor room is not sufficient
- Cooling air flow not sufficient
- Cooling pipes contaminated



Warning

Risk of burns!

Allow the unit to cool before beginning troubleshooting.

CYLINDER HEAD TEMPERATURE MONITORING

Spare part lists

Best.-Nr. / Order No.	Benennung	Description
004726	Display	Display
005585	Sensor	Sensor
007444	Ventilkopf (Spezielle Version)	Valve Head (special version)

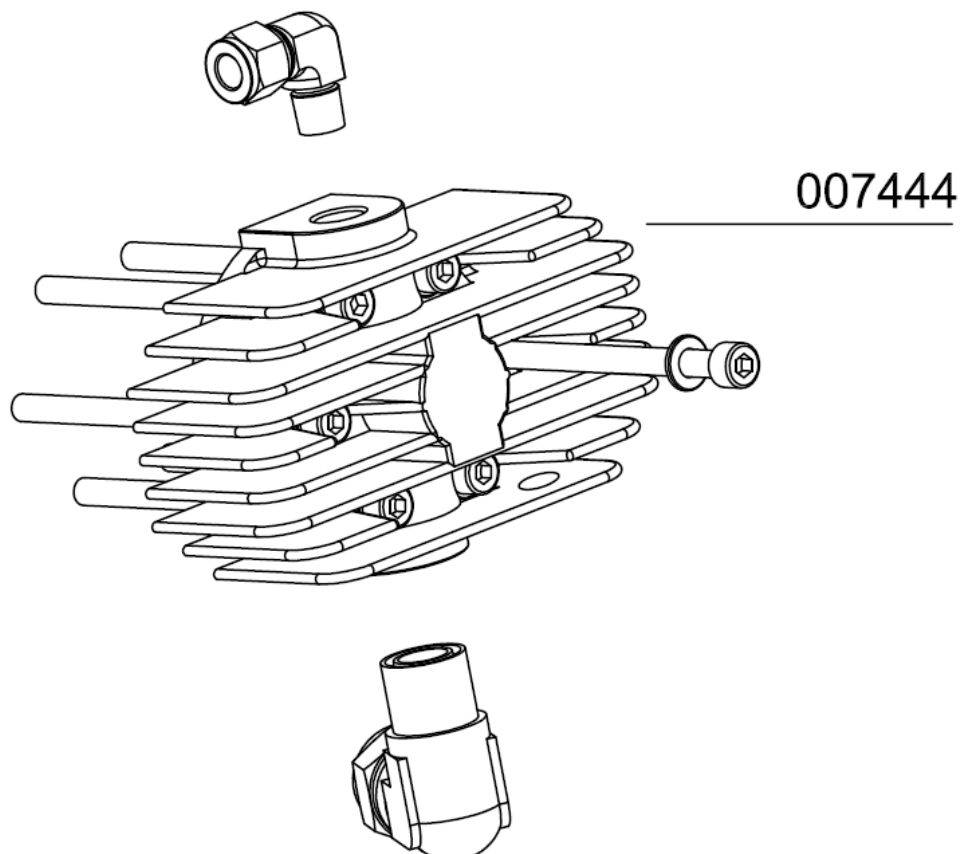
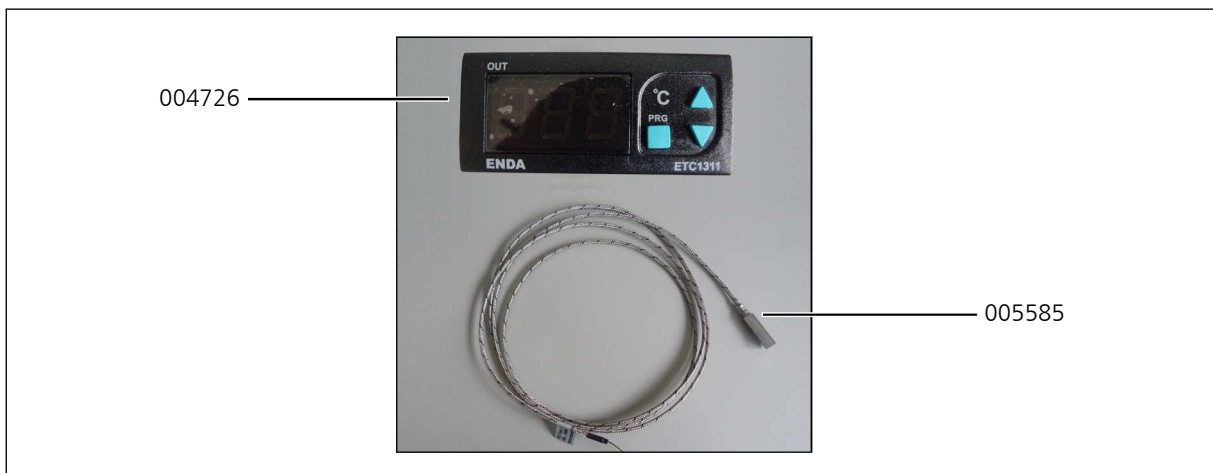



INTERSTAGE PRESSURE GAUGE

D

INTERSTAGE PRESSURE GAUGE

Interstage pressure gauge

Each of the 3 pressure stages is monitored by a single pressure gauge. This is serviceable for troubleshooting and allows detecting faults at an early stage.

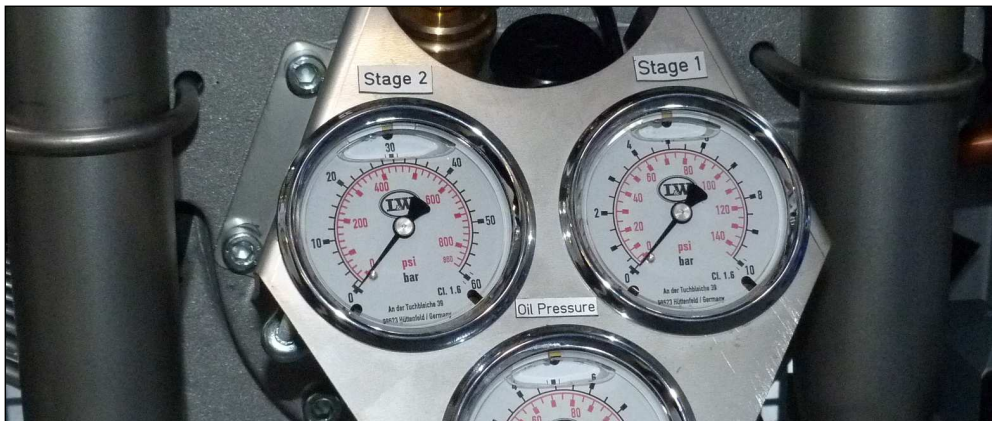

Indicated interstage pressures depend on final pressure settings.

The pressure gauges should show the following values at a final pressure of 300 bar:

1st stage: approx. 5 bar

2nd stage: approx. 42 bar

3rd stage: approx. 300 bar



INTERSTAGE PRESSURE GAUGE

Spare part lists

Best.-Nr. / Order No.	Benennung	Description
000660	Manometer 0-60 bar	Pressure Gauge 0-60 bar
000710	Verschraubung (1/8" -> 6L)	Connection (1/8" -> 6L)
001445	6L Manometerschlauch 600 mm	6L Hose for Pressure Gauge 600 mm
002281	Winkelverschr. mit fester Mutter	Elbow connection with fixed nut
002507	Manometer 0-10 bar	Pressure Gauge 0-10 bar

D

INTERSTAGE PRESSURE GAUGE

Spare part lists

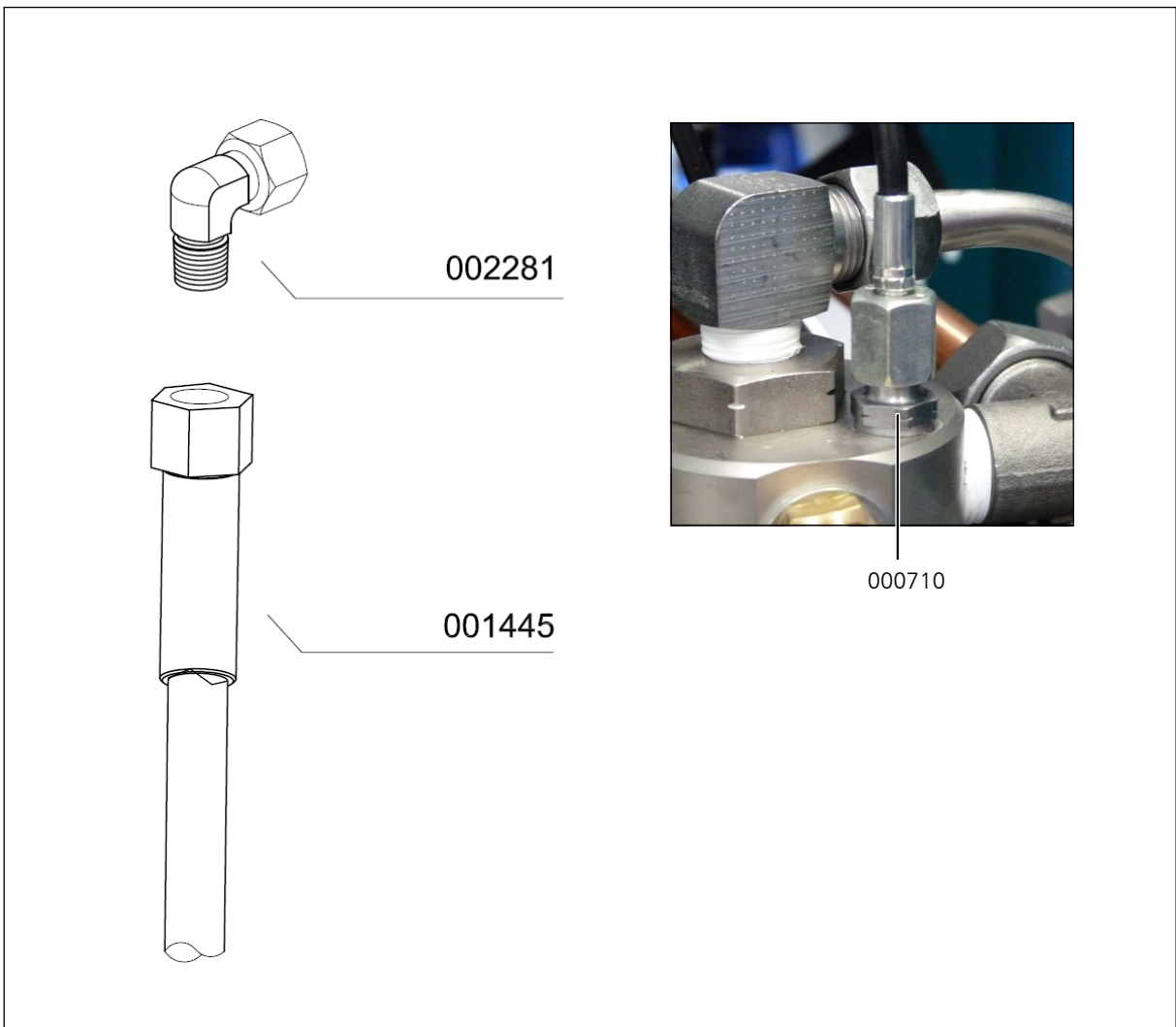
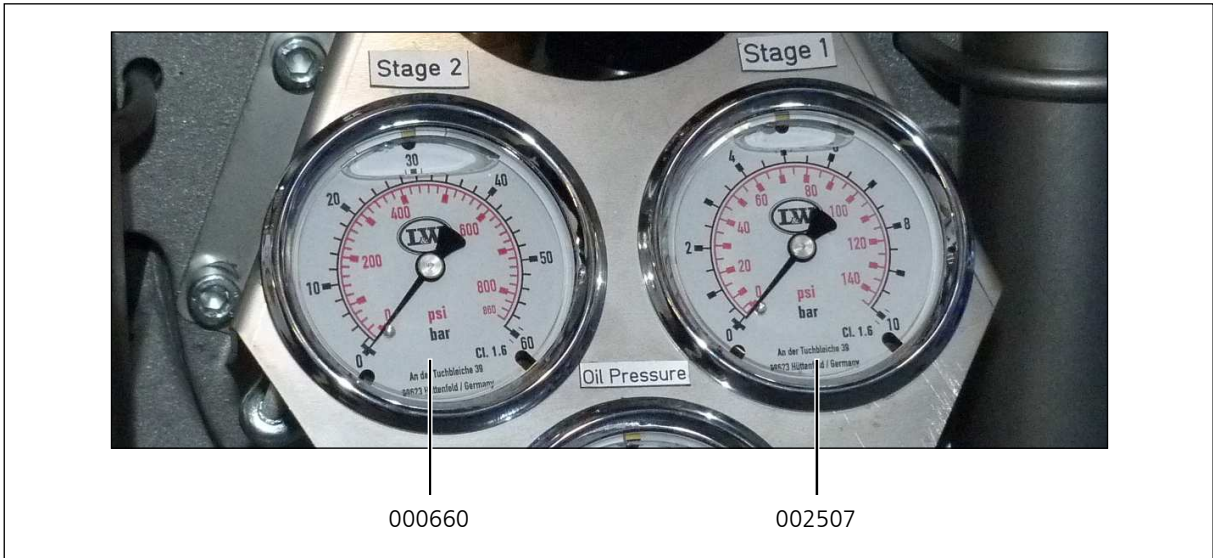



**200 / 300 BAR
PARALLEL FILLING
PRESSURE OPERATION**

D

200 / 300 BAR PARALLEL FILLING PRESSURE OPERATION

200 bar / 300 bar parallel filling pressure operation

This option allows the filling of 200 bar and 300 bar at the same time.

In this case, the compressor is equipped with a pressure reducer, a second final pressure safety valve and a second filling pressure gauge.

The handwheels or gaiters are colour-coded to allow an optical differentiation:

- 200 bar: black
- 300 bar: red

Furthermore, the corresponding filling pressures at the compressor are marked with labels.



DIN handwheels 200 bar and 300 bar



Fig. Pressure reducer: 330 / 225 bar



200 / 300 BAR PARALLEL FILLING PRESSURE OPERATION

Verrohrung 2 Druckbereiche / Spare Part List: Piping 2 Pressure Ranges

Best.-Nr. / Order No.	Benennung	Description
000233	Sockel für Sicherheitsventil	Base for Safety Valve
000566	Druckminderer	Pressure Reducer
000747	Verschraubung NPT 1/4" - 8L	Connection NPT 1/4" - 8L
000749	Verschraubung NPT 1/4" - 8L mit fester Mutter	Connection NPT 1/4" - 8L with fixed nut
000791	Verschraubung NPT 1/4" - 10L	Connection NPT 1/4" - 10L
000796	Winkelverschraubung 1/4" - 10L	Elbow Connection 1/4" - 10L
000797	Winkelverschraubung 10L mit fester Mutter	Elbow Connection 10L with fixed nut
004165	Halteblech Sockel für Sicherheitsventil	Bracket for Safety Valve Base
004935	Winkelverschraubung NPT 1/4" - 10L	Elbow Connection NPT 1/4" - 10L

D

200 / 300 BAR PARALLEL FILLING PRESSURE OPERATION

Verrohrung 2 Druckbereiche / Spare Part List: Piping 2 Pressure Ranges

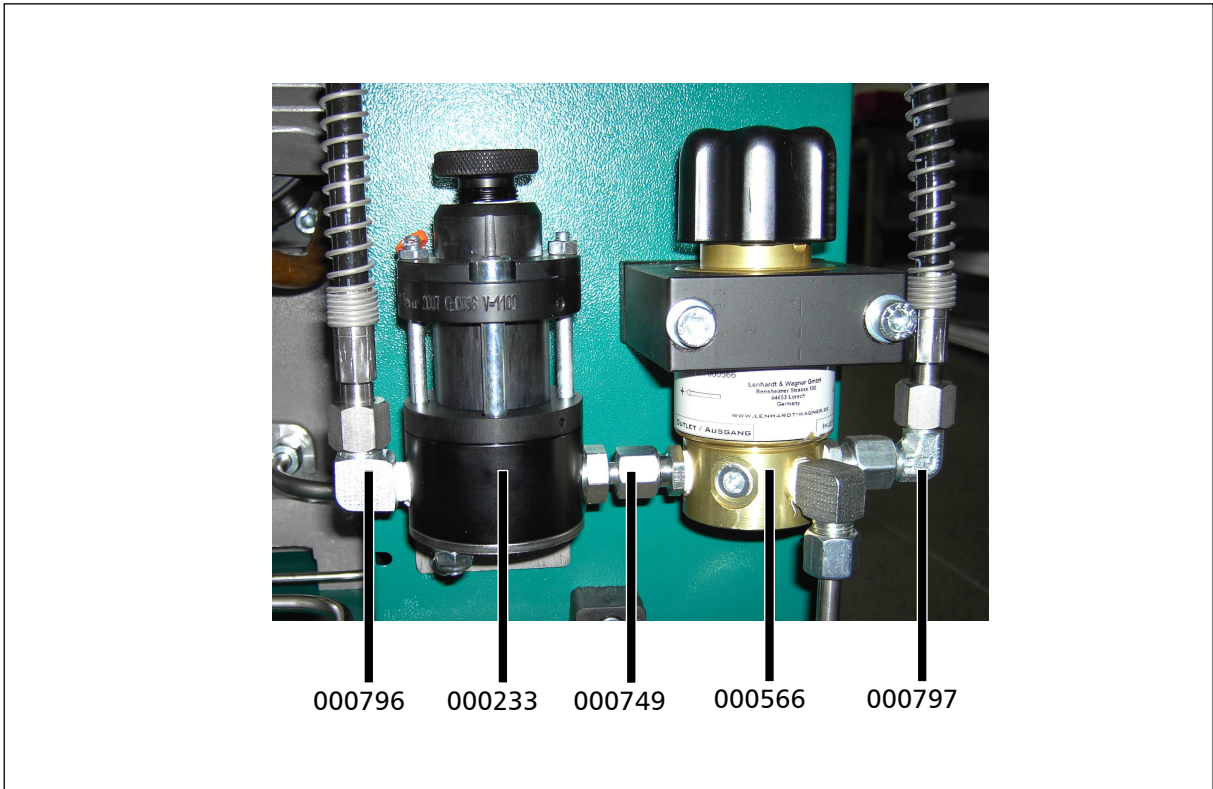

D

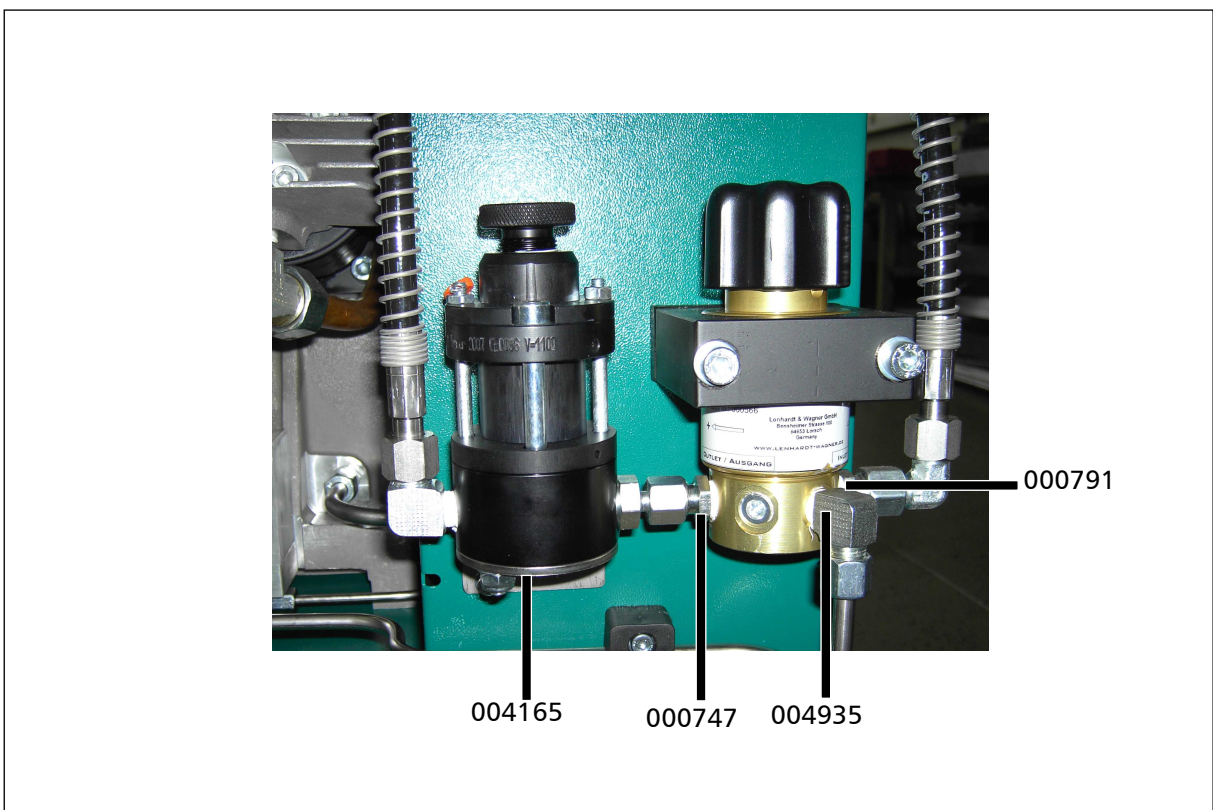



AIR COOLER CONNECTION KIT

D

AIR COOLER CONNECTION KIT

Air cooler connection kit

The Air Cooler Connection Kit provides an easy connection and a simple and time-saving installation or backfitting.

The piping inside the compressor is completely installed. Just disconnect the pipe of the safety valve to the inlet of the final filter housing and connect the air cooler according to the connection designation (inlet/outlet).

To operate the unit without air cooler, reinstall the pipe and the compressor is ready for use.



Zu entfernende Rohrleitung

D

All length of high pressure hoses available

The Air Cooler Connection Kit does not include the high pressure hoses. So you can't find any part numbers of our hoses in this chapter. We have a wide range of high pressure hoses in our product range. Please ask if you need special lengths.

AIR COOLER CONNECTION KIT

Spare part lists

Best.-Nr. / Order No.	Benennung	Description
000793	T-Verschraubung 10L	T-Connection 10L
000796	Winkelverschraubung 10L	Elbow Connection 10L

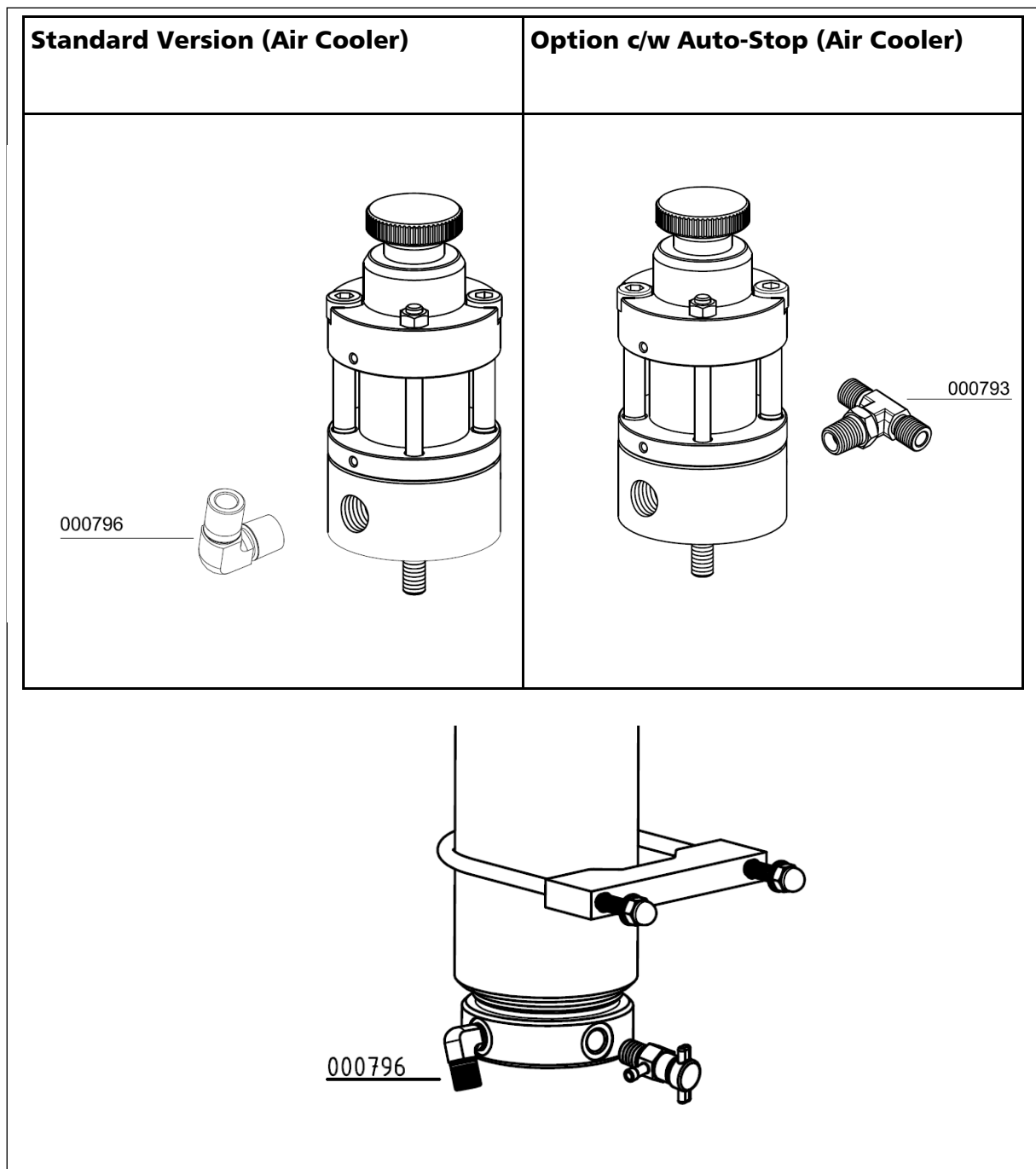

D



CONDENSATE TANK 60 LTR.

D

CONDENSATE TANK 60 LTR.

The 60 ltr. tank is equipped with an active carbon filter to collect condensate odourlessly and quietly. The condensate can be easily transported in the collecting tank and disposed environmentally sound.

The flexible connection hoses are fitted with quick-couplings, to allow easy separation from the compressor. The tank is equipped with a level gauge to indicate max. filling level. Two sturdy carrying handles ensure a safe transportation.

Technical Data:

- Dimensions: Ø 400 mm x 800 mm
- Weight: 20 kg



D

CONDENSATE TANK 60 LTR.

Maintenance and service

How to change the activated carbon and the metal filter insert

- Shut down the unit
- Plug out the condensate hoses
- Remove the protector cap, the nut and the allen bolts (Fig. 1)
- Take down the cover plate and the upper felt. Tip out the activated carbon and replace the lower felt
- Fill up the activated carbon and cover it with a new felt
- Put on the cover plate, screw the allen bolts and the nut and plug on the protector cap
- Unscrew the filter housing
- Remove the floater and the lower cover plate (Fig. 2)
- Take a pliers and pull the metal filter out of the metal case
- Insert the metal filter
- Install the cover plate and the floater
- Screw the filter housing onto the tank
- Plug in the condensate hoses

Maintenance intervals

We recommend to change the activated carbon if it has reached the saturation level (smell of oil).

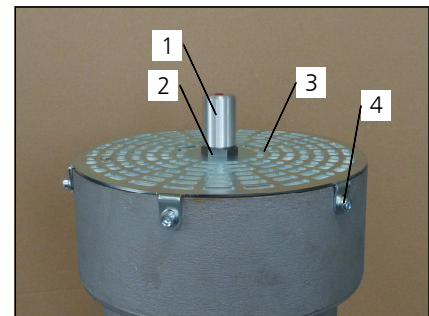

Fig. 1

- 1 Protector cap
- 2 Nut
- 3 Cover plate
- 4 Allen bolts (6x)

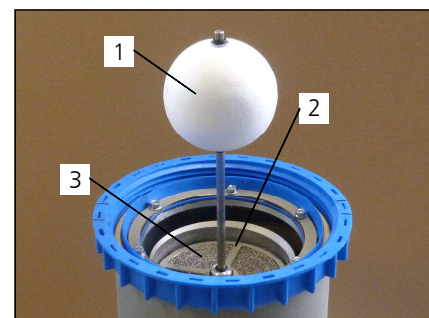

Fig. 2

- 1 Floater
- 2 Lower cover plate
- 3 Metal filter

CONDENSATE TANK 60 LTR.

Spare part lists

Best.-Nr. / Order No.	Benennung	Description
003091	Kondensatbehälter 60 Liter	Condensate Tank 60L
004056	Kondensatschläuche Kondensatbehälter 60L, für 3-	Set of condensate hoses, 3 stages
004057	Kondensatschläuche Kondensatbehälter 60L, für 4-	Set of condensate hoses, 4 stages

D

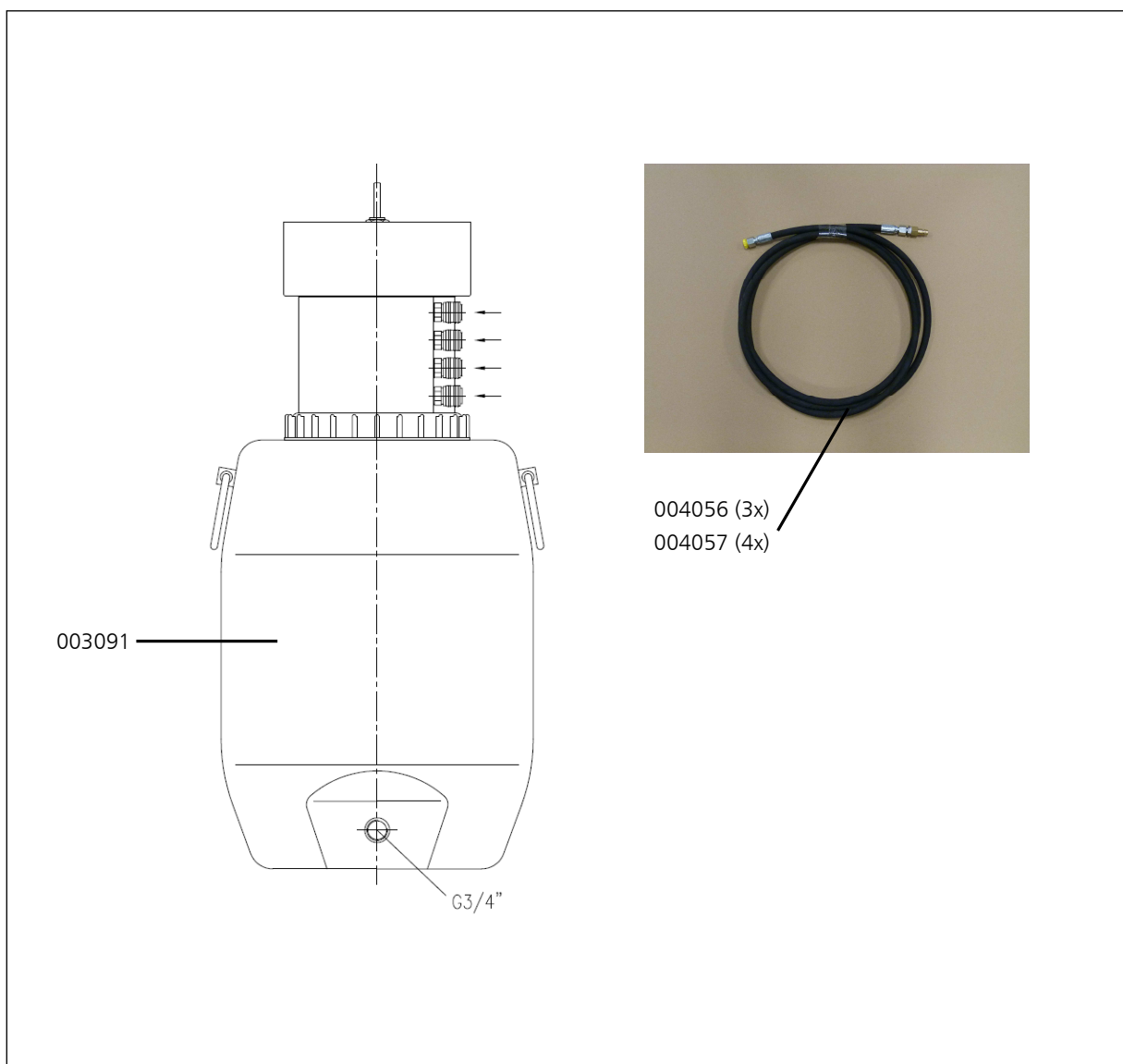

CONDENSATE TANK 60 LTR.

Spare part lists

Best.-Nr. / Order No.	Benennung	Description
000508	USIT-Ring 13,7 x Ø20 x 1,5	Gasket Ring U-Sit 13,7 x Ø20 x 1,5
003866	Filter Nachfüllset für 60 Liter	Filter refill set 60 ltr
004789	Schnellkupplung G1/4", DN 7,2	Quick connector G1/4", DN 7,2
006642	Metallgestrick für Kondensatbehälter 60 ltr	Metal filter insert 60 ltr tank

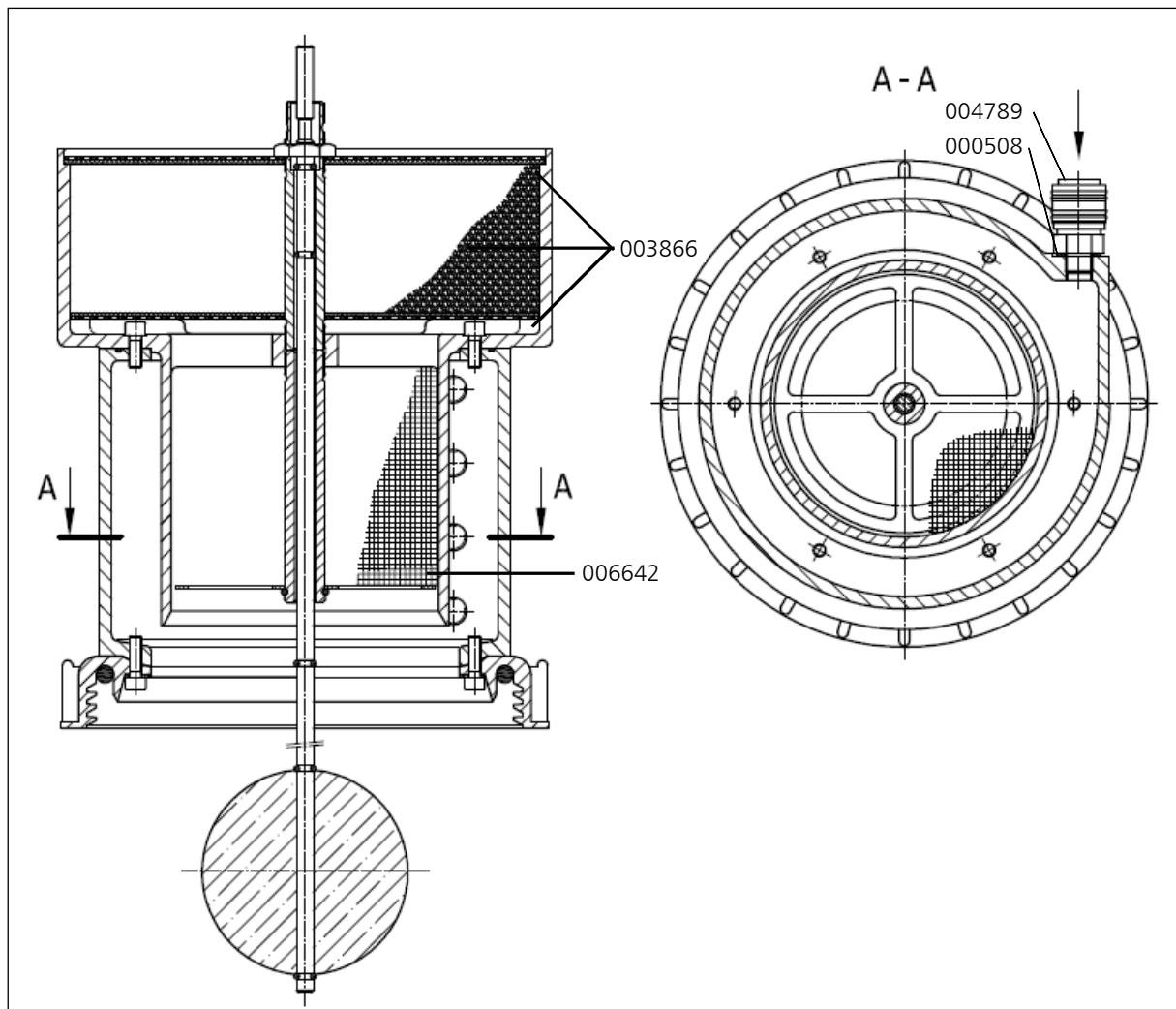

D



ATTACHMENT

E

Lenhardt & Wagner GmbH

**An der Tuchbleiche 39
D-68623 Lampertheim – Hüttenfeld**

www.lw-compressors.com



Operating Instruction

Safety valve

Typ:

SiV2 BKZ 989 TÜV.SV.12-989.5.G.V.P CE 0091 AlMgSi1 F31 1100* Lenhardt & Wagner

SiV BKZ TÜV.SV.14-1140.5.G.V.p CE 0091 AlMgSi1 F31 1100* Lenhardt & Wagner

Set pressure:	see mark (hand wheel on top of valve)
Maximum outflow:	Set pressure 100-159 bar: 750 l / min Set pressure 160-350 bar: 1.100 l / min
Suitable media:	Media-resistant, non-corrosive gases

The safety valve is used for protection of pressurized components, eg pipelines, pressure vessels, or the compressor itself.

The hand wheel on the top of the safety valve is marked with the adjusted set pressure.



- 1) **Identification of set pressure**
- 2) **Seal**
- 3) **Fixing screws¹**
- 4) **Venting screw (hand wheel)**
- 5) **Identification serial number**
- 6) **Socket for safety valve**

Safety valve with socket

¹ und die Anforderungen des AD 2000 Merkblatts W7 erfüllen. The fixing screws M8 must be strength class 8.8 and meet the requirements of Merkblatt AD 2000 leaflet W7. Shaft length 70mm.

In order to prevent manipulation of the set pressure, all safety valves are factory fitted with a seal.

A safety valve on which the seal has been removed, must be returned to the manufacturer for repair / adjustment before further use.

In addition, the safety valve has a venting device (hand wheel).

When rotated clockwise, the safety valve and the filter housing of the final stage are completely vented.

During normal operation, the screw is unscrewed to the upper stop anticlockwise; an integrated safety ring prevents the screw from being removed.

If a safety valve blows off, the system must be switched off immediately and the cause of the error, investigated.

There are two possible reasons:

1. The safety valve is defective and blows off before the set pressure.

In this case the safety valve should be submitted immediately to the manufacturer for repair or replaced with a new one.

2. The safety valve opens properly, the problem is on the system.

A constant blowing of the safety valve is not permitted, the sealing seat of the valve can be damaged. The error on the system must be detected and repaired before further filling operations.

The safety valve may only be used if it is ensured that the maximum flowrate of the system does not exceed the blow-off rate of the safety valve.

The safety valve may only be used with the approved media.

Repair work on compressors must only be performed by trained personnel.

Dismantling of the safety valve

Ensure that on the safety valve is no pressure.

Loosen and remove the two M8 fixing bolts with a 6 mm Allen key.

The safety valve can now be removed by turning and simultaneously pulling out of the socket.

Mounting

1. Clean the safety valve socket.

2. Oil the insert pin of the safety valve including the O-ring with 1 to 2 drops of oil.

3. Press the safety valve pin complete into the socket.

4. Fasten the safety valve with the two 8 mm allen screws into the socket

(Tightening torque: 10 Nm)

5. Screw the venting screw (hand wheel) anticlockwise to its upper limit.

6. Start the System (Compressor), check installation for leaks and proper function.

Manufacturer: Lenhardt & Wagner GmbH
An der Tuchbleiche 39
D-68623 Lampertheim – Hüttenfeld

Contact: E-Mail: service@lw-compressors.com
Web: www.lw-compressors.com
Tel.: +49 (0) 6256 – 85880 0
Fax: +49 (0) 6256 – 85880 14

Note:

Only use safety valves which are in a technically perfect condition, for its intended purpose, safety and danger awareness, in compliance with the operating instructions!
Faults which could affect safety must be rectified immediately!

Notes:

- The safety valve must be installed directly on the protected pressure vessel and / or the plant.
 - The safety valve must be installed in an upright position.
 - The flow area of the port must be greater than the valve opening.
 - Protect valve against splashes
-

Maintenance:

- In accordance with current Pressure Equipment Directives, the safety valve must be periodically checked for operation and reliability.
- Refill annually lubricating oil:
Oil filling position:
Hole on the spacer (see arrow, Figure 1)
- Oil level: Fill oil into the hole until oil comes out of the hole.

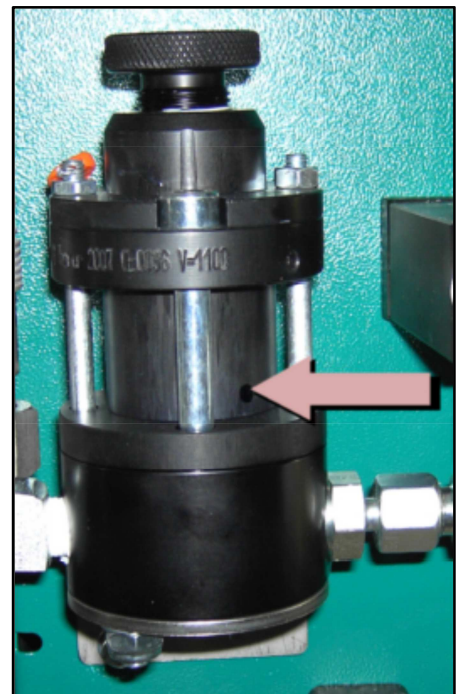

Figure 1: Position for oil refill

To be used lubricating oil for the safety valve: L&W Article N°.: 008500 (content: 30 ml)



INFORMATION ON THE
SERVICE LIFE OF
L&W HIGH PRESSURE HOSES





CONTENTS

Testing hose lines	
Testing hose lines	3
Testing after assembly and before commissioning	3
Recurring test	4
Procedure for hose lines found to be "defective"	4
Test intervals.....	4
Persons qualified to test hose lines.....	5
 Maintenance	
Replacing hose lines	6
Immediate replacement of hose lines	6
 Service life	
Service life of L&W high pressure hoses.....	7
 Storage	
Storing hose lines	8
 Annex	
Scope of testing, test criteria	10 - 11



TESTING HOSE LINES

Testing hose lines

An essential factor in ensuring operational safety when handling L&W compressors is the proper testing of the hose lines used.

Tests are necessary:

- After assembly and before commissioning the hose line.
- After accidents, changes (modifications) to the compressor system, longer periods of non-use and damage due to, for example, collisions or natural phenomena (extraordinary test).
- After carrying out repair work on the compressor system that could compromise safety.
- Recurrently at fixed, regular intervals.

The proprietor must determine the type, scope and deadlines for the tests according to his or her individual operating conditions and on the basis of a risk assessment. **The specifications and recommendations of the manufacturer must be observed.** The specifications made regarding type, scope and deadlines (as well as the replacement intervals) must be documented in writing as occupational health and safety measures.

The results of the tests must also be recorded, e.g. together with the test report of the machine, and kept at least until the next test.

The above-mentioned tests may only be carried out by persons who are qualified to do so and who are authorized by the company (employer).

Testing after assembly and before commissioning

In the test after assembly and before commissioning, factors relating to assembly or factors that can only be evaluated on the fully assembled machine must be assessed.

The assembled hose lines must also be assessed.

Some test points can already be assessed during a visual inspection when the machine is switched off.

An overview of the recommended scope of testing for a visual inspection of hose lines is given in the appendix.

Further test points included in the test of hose lines before commissioning, require a functional test with the machine running.

A recommendation for the scope of testing is given in the appendix.



TESTING HOSE LINES

Recurring test

Since hose lines are subject to influences that cause damage during operation and can lead to dangerous situations, they must be tested recurrently at fixed intervals. The aim of recurring tests is to detect and repair damage in good time.

The objective is to ensure that the system remains in a safe condition.

Procedure for hose lines found to be "defective"

If defects are found during the testing of the hose line that impair the safe condition of the work equipment, these must be rectified immediately. If this is not possible, suitable measures must be taken to ensure that the machine cannot be used further before it is repaired. Defective hose lines must be replaced before the machine can be used further.

It is not permitted to repair or reassemble damaged hose lines with old, previously used parts!

If several hose lines are replaced at the same time, precautions must be taken to prevent mix-ups of the connections or the installation points.

Test intervals

Deadlines for the recurring tests of the hose lines should already be set before commissioning.

Otherwise, there is a risk that work equipment will continue to be used or operated for too long without being tested.

The intervals between the recurring tests must be selected in such a way that deviations from the safe operating condition of work equipment can be detected and eliminated in good time.

The intervals for recurring tests specified here are guidelines and based on experience. Shorter test intervals may have to be specified on the basis of the risk assessment; special operating conditions; or according to the manufacturer's specific instructions in the machine operating manual. Longer test intervals may also be specified, provided that this is justifiable and tenable from a safety point of view. The determination of the test intervals should be documented.

Type of test	Recommended test intervals
Visual inspection	Before commissioning the system
Functional test	Annually with previous visual inspection

Persons qualified to test hose lines

A qualified person is a person who, through his or her professional training, professional experience and recent professional activity, has the necessary specialist knowledge required for testing work equipment - in this case for testing hose lines.

These requirements are defined in the Technical Rules for Industrial Safety TRBS 1203

"Qualified persons - general requirements" fulfilled if:

- the qualified person has completed a professional training that enables his or her professional knowledge to be determined in a comprehensible manner, i.e. based on professional qualifications or comparable evidence. For the testing of hose lines, the person concerned must have completed a technical professional training or another technical qualification sufficient for the intended testing tasks. The object is to guarantee that the tests will be carried out properly.
- proof of practical use at work of the equipment to be tested as well as the associated professional experience is provided. The qualified person must be sufficiently familiar with the conditions that demand the performance of tests, such as the result of the risk assessment or observations during the working day.
- there is proof of recent professional activity in the area of the upcoming tests and appropriate further training. The qualified person must also have gained experience with regard to the tests to be performed or comparable tests. He or she must also have knowledge of the state of the art with regard to the work equipment or components to be tested as well as the hazards to be considered. This also includes knowledge of the relevant technical regulations and the updating of this knowledge, e.g. through participation in training courses/instruction.

The qualified person is not subject to any technical instruction during the course of his or her testing activity and must not be disadvantaged because of this.

Experts who have carried out tests on the hose lines up to now and who meet the three criteria mentioned above and who have familiarized themselves with the contents of the German Ordinance on Industrial Safety and Health and the changes associated with it are also considered qualified persons to whom the tests can continue to be assigned.

See also:

- ⇒ § 2 para. 7 of the German Ordinance on Industrial Safety and Health,
- ⇒ Technical Rules for Operational Safety TRBS 1203.



Replacing hose lines

As a general rule, even when stored properly and subjected to permissible stress during use, all hose lines are subject to natural aging, which changes the material and composite properties and reduces the performance of the hose lines.

This limits the service life of a hose line and the operator must ensure that hose lines are replaced at appropriate intervals.

Immediate replacement of hose lines

Hose lines must be replaced immediately in the event of the following defects:

- External visible damage to the hose line or fittings.
- Internal damage to the tube or the reinforcement.
- Leakage from the hose line or the fittings.
- Deformation of the hose line or the fittings.



SERVICE LIFE

Service life of L&W high pressure hoses

When determining the service life or the replacement interval of the individual hose lines, the concrete specifications and recommendations of the hose line or machine manufacturer must be observed. Furthermore, empirical values resulting from previous tests done under the prevailing operating conditions on site are also relevant.

Guideline values for recommended replacement intervals of hose lines which have proven themselves in practice are summarized below.

Hose line requirements	Recommended replacement intervals
Standard requirements	6 years (Service life including a maximum of 2 years storage time)
Increased requirements, e.g. due to - increased operating time, e.g. multi-shift operation, or short machine or pressure pulse cycle times - strong external and internal influences (due to the medium), which greatly reduce the service life of the hose line	2 years (service life)

The guideline given above for a replacement interval of six years for hose lines meeting normal requirements includes a maximum storage period of two years. The guideline value of two years for hose lines meeting increased requirements represents the maximum permissible service life.

A prolongation of the guideline values given above for replacement intervals is possible if

- appropriate test values and empirical values are available from the operator of the machine which permit safe continued use beyond the recommended maximum service period,
- a hazard or risk assessment, documented in writing, has been carried out by the operator, which also takes into account protective measures in the event of failure of hose lines, and
- tests for safe working conditions are carried out by qualified persons at appropriately set, if necessary reduced, intervals.

It must be ensured that the prolongation of the replacement intervals does not result in a dangerous situation that could injure employees or other persons.

If hose lines fail during operation or if damage or defects are frequently detected during the recurring tests, then, in addition to investigating the causes, the test and replacement intervals must be shortened.



STORAGE

Storing hose lines

When storing hose lines, storage conditions must be aimed at minimizing the natural aging that occurs over time and the associated change in material and composite properties.

For this purpose, the following information must be provided:

- Store in a cool, dry and low-dust place.
Low-dust storage can be achieved, for example, by wrapping the hoses in plastic film.
- Avoid direct sun or UV radiation.
- Shield from nearby heat sources.
- Avoid storage temperatures below -10 °C for elastomers.
- Do not use ozone-generating light fittings or electrical devices that may produce sparks in the immediate vicinity.
(Ozone-generating light fittings are, for example, fluorescent light sources, mercury vapor lamps).

The most favorable storage conditions are temperatures between +15 °C and +25 °C, as well as a relative humidity below 65 %.

During storage, hose lines must not come into contact with substances that could cause damage, e.g. acids, alkalis, solvents. Penetration of ozone or other harmful air constituents can be prevented by sealing the ends or by wrapping the hoses in plastic film. They must be stored flat and free of tension.

The storage period for hose lines should not exceed two years.



ANNEX

Recommended scope of testing "visual inspection" (before initial commissioning or recommissioning)

- Is all user information required for safe operation of the system available (e.g. flow chart, operating instructions)?
- Do the hose lines comply with the flow chart or parts list?
- Are there protective measures in place, such as pressure relief valves, for cases of unusually high pressure pulses or pressure amplifications?
- Are the hose lines marked with the name or abbreviation of the manufacturer, maximum permissible operating pressure, nominal diameter, quarter/year of manufacture?
- Are the hose lines installed in such a way that, in accordance with DIN 20 066
 - the natural position does not hinder movement?
 - turning or twisting of the hose is prevented, likewise tensile load caused by a line that is too short and a bending radii that is too small?
 - the hose is routed via a kink protector (if necessary on the connecting element)?
 - sufficient clearance prevents external mechanical influences or abrasion on the edges?
 - hose bridges prevent damage being caused by driving over the hose line?
 - hose guides (such as hose saddles and sufficiently wide hose brackets) protect loosely laid hose lines and
 - a heat shield protects against high temperature exposure?
- Are suitable protective measures, such as fixtures, safety gear or shielding provided for hose lines that, in the event of failure, pose a risk of whipping?
A risk is to be assumed if persons are generally present in the immediate vicinity of the hose lines, for example.
- Do the hose lines of newly commissioned or re-commissioned machines already show signs of damage?
- Are the installed hose lines still within the storage/use period recommended by the relevant manufacturer?
- Are the hose lines free of paint?
- Are the hose lines free of chafe marks?
- Does the operating manual contain information on test intervals? If so, what?

Note:

The installed hose lines should not be made from used hoses or used press fittings that have already been in use as part of a hose assembly!



ANNEX SCOPE OF TESTING; TEST CRITERIA

Recommended scope of testing "Functional test" (before initial or recommissioning)

Note:

Visual inspection must be carried out before the functional test

- All parts of the system must be tested at least at the maximum working pressure that could be achieved taking into account all intended applications:
 - Are the hose lines and connecting elements free of leakage?
 - Have all hose lines withstood the pressure?

Note:

The installed hose lines should not be made from used hoses or used press fittings which have already been in use as part of a hose assembly!