



## CHAPTER OVERVIEW

---

**Operating Instructions** .....

A

**ECC - Electronic Compressor Control (if equipped)**.....

B

**Spare Parts Lists** .....

C

**Options (if equipped)**.....

D

**Attachment** .....

E

### Manufacturer in terms of 97/23/EC

The full name and address of the manufacturer is:

Lenhardt & Wagner GmbH

An der Tuchbleiche 39

68623 Hüttenfeld / Germany

Phone: +49 (0) 62 56 - 85 88 0 - 0

Fax: +49 (0) 62 56 - 85 88 0 - 14

E-Mail: [service@lw-compressors.com](mailto:service@lw-compressors.com)

Internet: [www.lw-compressors.com](http://www.lw-compressors.com)





## SERVICE INFORMATION / WARRANTY

---

### Compressor information

\_\_\_\_\_

Type designation

\_\_\_\_\_

Serial number

\_\_\_\_\_

Date of construction

### Purchase information

\_\_\_\_\_

Purchase date

\_\_\_\_\_

First commissioned on

\_\_\_\_\_

Warranty period

\_\_\_\_\_

Dealer's stamp

### Warranty

L&W will uphold warranty claims made during a period of 12 months from the invoice date.

If the compressor was purchased from an official L&W dealer, the date on the dealer's invoice is valid. Warranty claims can only be made on presentation of the original invoice.

Should verifiably defective parts have been delivered, we will decide to either replace the parts or repair them. The resulting transport and assembly costs will be invoiced.

No reduction of the purchase price or changes to the contract can be made. The parts for which a claim is being made should be kept safe by the purchaser and, when requested, sent to us at their cost. Replaced parts become the property of L&W. If maintenance work is carried out without our knowledge or permission by the purchaser or a third party, we are absolved from any liability for warranty claims. As a matter of principle, warranty claims can only be made by the initial purchaser.

---

# Operating Instructions

Breathing Air Compressor

LW 300 E III / LW 450 E III





## TABLE OF CONTENTS

---

### General Information and Technical Data

General Information / Description of Warning Symbols .....	4
Scope of Delivery .....	5
Technical Data .....	6
Unit Assembly .....	7
Switchboard .....	8
Flow chart .....	9

### Safety Precautions

Intended Use / Operators .....	11
Safety instructions on the unit .....	12
General Safety Precautions .....	13
Unit customised safety notices .....	14
Maintenance instructions .....	15
Transportation instructions / Safety regulations .....	16

### Installation

Installation in closed rooms .....	18
Dimensions .....	19
Minimum distances .....	20
Ventilation .....	21
Electrical Installation .....	22 - 23

### Operation

Important operation instructions .....	25
First commissioning .....	26 - 28
Daily commissioning .....	29
Filling procedure .....	30
Switch off the compressor .....	31

<b>Remedying faults</b> .....	32 - 36
-------------------------------	---------

### Maintenance and Service

Service, Repair and Maintenance .....	38
Maintenance Lists / Maintenance Intervals .....	39 - 42
Service Kits .....	43
Check V-belt tension / Tension V-belt .....	44
Compressor lubrication / Check oil level .....	45
Oil change .....	46
Oil sieve change .....	47
Final pressure switch .....	48

A





## TABLE OF CONTENTS

---

### Maintenance and Service

Automatic condensation dump system .....	49
Oil / water separator 1st stage - maintenance .....	50 - 51
Oil / water separators 2nd stage - maintenance .....	52 - 53
Condensate-stop-valve - maintenance .....	54
Pneumatic condensate valve - maintenance .....	55
Filter housing 1.7ltr / 0.8ltr .....	56
1.7ltr filter cartridge change .....	57
1.7ltr filter housing - maintenance .....	58
0.8ltr filter element change .....	59
0.8ltr pre-filter housing - maintenance .....	60
Inlet filter / Inlet filter cartridge change .....	61
Cylinder heads and valves .....	62
Replace inlet and outlet valves 1st and 2nd stage .....	63 - 64
Replace inlet and outlet valve 3rd stage .....	65
Replace piston rings and needle bearings of the 2nd and 3rd stage .....	66 - 67
Safety valves .....	68
Pressure maintaining / non return valve .....	69
Safety valve test .....	70
Leak test .....	71
Pressure gas vessel test .....	72
Maintenance records .....	74 - 78

### Storage

Conservation / storage of the compressor .....	79
De-conservation, commissioning .....	79
Transportation instructions / Disposal .....	80

A

## GENERAL INFORMATION

---

### General Information

We strongly recommend reading this manual thoroughly prior to operation and follow all the safety precautions precisely. Damage resulting from any deviation from these instructions is excluded from warranty and liability for this product. Carry out other commissioning steps only if you have fully understood the following contents.

Before commissioning and using the unit, carry out all the essential preliminary work and measures concerning legal regulations and safety. These are described on the following pages of this operation manual.

A

### Description of marks and warning signs

The following warning signs are used in this document to identify the corresponding warning notes which require particular attention by the user. The warning signs are defined as follows:



#### Caution

Indicates an imminently hazardous situation which, if not avoided, could result in serious injury, physical injury or death.



#### Warning

Indicates a potentially hazardous situation which, if not avoided, could result in physical injury or damage to the product or environment.



#### Note

Indicates additional information on how to use the unit.



## DESCRIPTION

---

### Scope of Delivery

Compressors are provided in different equipped versions.

A

### Versions

#### Filling pressure versions:

- PN 225 bar
- PN 330 bar
- PN 225 / 330 bar

### Specifications

- Automatic condensate drain
- Automatic stop at final pressure
- Hour counter
- Start/Stop and emergency stop switch, condensate test buttons
- Motor protection switch, emergency stop switch
- Pressure maintaining and non-return valve
- All pistons c/w steel piston rings
- Low pressure oil pump and filter
- Oil / water separators after each stage
- Safety valves after each stage
- 3x concentric suction/pressure valves

### Options

- Auto start system
- 200 and 300 bar parallel filling operation
- Oil pressure display
- Intermediate pressure gauges
- Oil pressure monitoring c/w auto shut down
- Cylinder head temperature monitoring with auto shut down
- Oil temperature display with auto shut down
- Puracon filter monitoring
- ECC control in remote control box
- Additional high pressure outlet
- Direction of rotation monitoring
- Power cable and plug

## DESCRIPTION

### Technical Data



Technical Data	LW 300 E III	LW 450 E III
Capacity [l/min]:	300	450
Max. Operating Pressure [bar]:	350	350
RPM [min <sup>-1</sup> ]:	-	1,100
Number of Pressure Stages:	3	3
Cylinder Bore 1st Stage [mm]:	Ø 95	Ø 95
Cylinder Bore 2nd Stage [mm]:	Ø 42	Ø 42
Cylinder Bore 3rd Stage [mm]:	Ø 18	Ø 18
Medium:	Compressed Air / Breathing Air	Compressed Air / Breathing Air
Intake Pressure:	atmospheric	atmospheric
Oil Pressure (at operating temperature) [bar]:	+1.5 (-0,2)	+1.5 (-0,2)
Oil Capacity [l]:	2.7	2.7
Intake Temperature [°C]:	0 < +45	0 < +45
Ambient Temperature [°C]:	+5 < +45	+5 < +45
Cooling Air Volume [m <sup>3</sup> /h]:	-	> 3,300
Voltage:	-	400 V / 3 phase / 50 Hz
Protection Class Drive Motor:	-	IP 54
Drive Power [kW]:	-	11
RPM Motor [min <sup>-1</sup> ]:	-	2,890
Start:	-	Star/Delta
Noise level [dB(A)]:	82 from a distance of 1 m	83 from a distance of 1 m
Dimensions W x D x H [mm]:	1540 x 730 x 1020	1540 x 730 x 1020
Weight [kg]:	ca. 365	ca. 365
Content Volume Filter housing [l]:	0.8	0.8
Content Volume Filter housing [l]:	1.7	1.7

## DESCRIPTION

### Unit Assembly

A



No.	Designation
1	Filling pressure gauge
2	Switchboard
3	Filling hoses (optional: without filling hoses)
4	Filling valves

## DESCRIPTION

### Switchboard

A



No.	Designation
1	Emergency shut-off switch
2	Hour counter
3	ON button
4	OFF button
5	Drain test button

## DESCRIPTION

### Flow chart

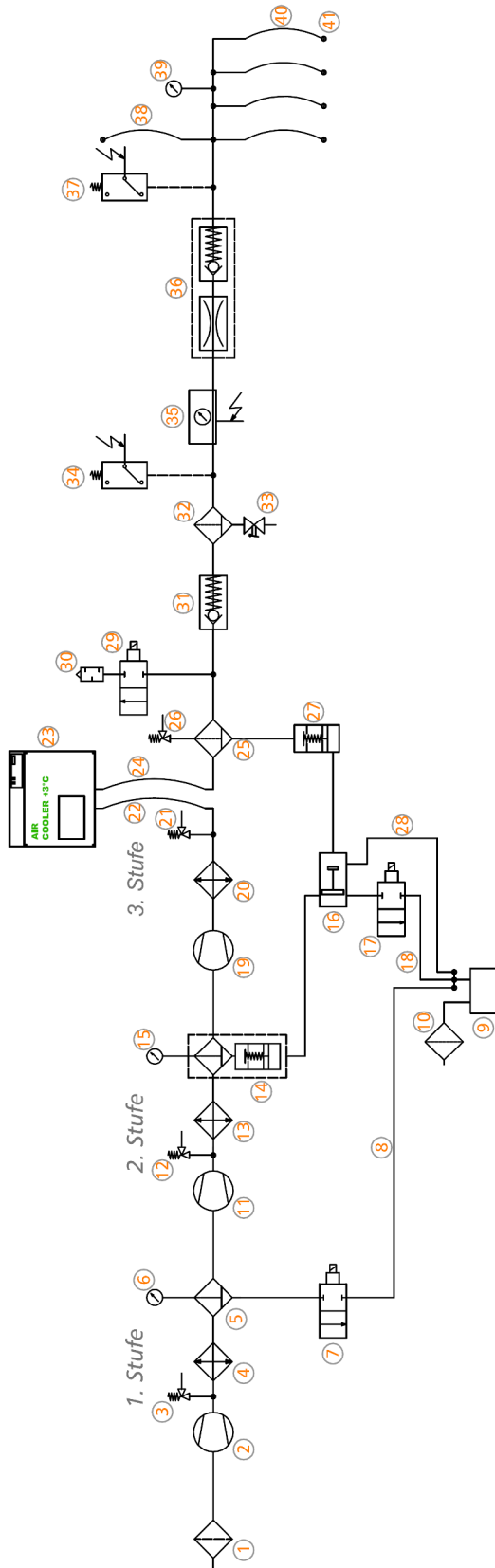

1. Ansaugfilter / Air Intake Filter
2. 1. Verdichterstufe / 1st Pressure Stage
3. Sicherheitsventil 1.Stufe / Safety Valve 1st Stage
4. Wärmetauscher / Heat Exchanger
5. Öl-/Wasserabscheider / Oil Water Separator
6. Manometer (Option) / Pressure Gauge (Option)
7. Kondensatventil / Condensate Valve
8. Kondensatablassschlauch / Condensate Release Hose
9. Kondensatsammelbehälter / Condensate Tank
10. Filter/Schalldämpfer / Filter/Silencer
11. 2. Verdichterstufe / 2nd Pressure Stage
12. Sicherheitsventil 2.Stufe / Safety Valve 2nd Stage
13. Wärmetauscher / Heat Exchanger
14. Öl-/Wasserabscheider mit integriertem Kondensat-Stopp-Ventil / Oil-/Water Separator with integrated Condensate-Stop-Valve
15. Manometer (Option) / Pressure Gauge (Option)
16. Pneum. Kondensatventil / Pneumatic Condensate Valve
17. Kondensatventil / Condensate Valve
18. Kondensatablassschlauch / Condensate Release Hose
19. 3. Verdichterstufe / 3rd Pressure Stage
20. Wärmetauscher / Heat Exchanger
21. Sicherheitsventil 3.Stufe (Option Air Cooler!) / Safety Valve 3rd Stage (Option Air Cooler)
22. HD-Schlauch (Option) / HP-Hose (Option)
23. Air-Cooler (Option)
24. HD-Schlauch (Option) / HP-Hose (Option)
25. Filterbehälter 0,8l / Filter Case 0.8ltr
26. Sicherheitsventil 3.Stufe / Safety Valve 3rd Stage
27. Kondensat-Stopp-Ventil / Condensate-Stop-Valve
28. Kondensatablassschlauch / Condensate Release Hose
29. Entlüftungsventil / Ventilation Valve
30. Schalldämpfer / Silencer
31. Rückschlagventil / Non-Return Valve
32. Filterbehälter 1,7 / Filter Case 1.7ltr
33. Kondensatablass-Ventil / Condensate Release Valve
34. Druckschalter (Auto Stopp) / Pressure Switch (Auto-Stop)
35. Puracon-Sensor (Option)
36. Druckhalte-Rückschlagventil / Pressure Maintaining Non-Return Valve
37. Druckschalter Auto Start (Option) / Pressure Switch Auto Start (Option)
38. HD-Schlauch (Option) / HP-Hose (Option)
39. Manometer / Pressure Gauge
40. HD-Füllschlauch / HP-Filling Hose
41. Füllanschlüsse / Filling Connections

A



A

# SAFETY PRECAUTIONS





## SAFETY PRECAUTIONS

---

### Intended Use

Only use the unit in perfect condition for its intended purpose, safety and intended use and observe the operating instructions! In particular disorders that may affect safety have to be eliminated immediately!

Use the unit exclusively for the determined medium (see "Technical Data"). Any other use that is not specified is not authorized. The manufacturer/supplier shall not be liable for any damages resulting from such use. Such risk lies entirely with the user. Authorization for use is also under the condition that the instruction manual is complied with and inspection and maintenance requirements are enforced.

No change and modification to the unit can be made without the written agreement of the manufacturer. The manufacturer is not liable for damage to persons or property resulting from unauthorized modifications.

### Operators

Target groups in these instructions;

#### Operators

Operators are persons who are authorized and briefed for the use of the compressor.

#### Qualified personnel

Qualified personnel are persons who are entitled to repair, service, modify and maintain the system.



#### Warning

Only trained personnel are permitted to work on the unit!



#### Warning

Work on the electrical equipment on / with the machine / unit may only be carried out by qualified electricians.

## SAFETY PRECAUTIONS

---

### Safety instructions on the unit

Importance of notes and warning signs that are affixed to the compressor according to the application or its equipment.

A



**Warning**  
High voltage!



**Note**  
Ensure correct direction of rotation!



## **SAFETY PRECAUTIONS**

---

### **General Safety Precautions**

- Read the Operating Instructions of this product carefully prior to use.
- Strictly follow the instructions. The user must fully understand and strictly observe the instructions. Use the product only for the purposes specified in the intended use section of this document.
- Do not dispose the operating instructions. Ensure that they are retained and appropriately used by the product user.
- Only trained and competent personnel are permitted to use this product.
- Comply with all local and national rules and regulations associated with this product.
- Only trained and competent personnel are permitted to inspect, repair and service the product.
- Only authentic L&W parts and accessories may be used for maintenance work. Otherwise, the proper functioning of the product may be impaired.
- Do not use faulty or incomplete products. Do not modify the product.
- Inform L&W in the event of any product or component fault or failure.
- The quality of the air supply must meet EN 12021 specifications for breathing air.
- Do not use the product in areas prone to explosion or in the presence of flammable gases. The product is not designed for these applications. An explosion might be the result if certain conditions apply.

**A**



## **SAFETY PRECAUTIONS**

---

### **Unit customised safety notices**

#### **Organisational measures**

- In addition to the instruction manual, observe and comply with universally valid legal and other obligatory regulations regarding accident prevention and environment protection.
- In addition to the instruction manual, provide supplementary instructions for supervision and monitoring duties taking into consideration exceptional factors e.g. with regard to organisation of work, production, personnel employed.
- Supervise personnel's work in accordance with the instruction manual, taking into account safety and danger factors.
- Observe all safety and danger notices on the compressor and check readability and completeness.

#### **Safety instructions operation**

- Take measures to ensure that the machine is only taken into operation under safe and functional conditions. Only operate the compressor if all protective and safety equipment, e.g. detachable protective equipment, are provided and in good working order.
- Check the compressor at least once per day for obvious damage and defects. Inform the responsible department / person immediately if anything is not as it should be (including operation performance). Shut down the machine immediately if necessary and lock it.
- In case of malfunction, stop the compressor immediately and lock it. Repair malfunctions immediately.
- If there is a failure in the electric energy supply, shut the machine / unit down immediately.
- Ensure safe and environmentally friendly disposal of consumables and old parts.
- The stipulated hearing protectors must be worn.
- Soundproofing equipment on the compressor has to be activated in safety function during operation.
- When handling with fats, oils and other chemical agents, observe the note for the product-related safety.

**A**



## SAFETY PRECAUTIONS

---

### Maintenance instructions

- Hoses have to be checked by the operator (pressure and visual inspection) at reasonable intervals, even if no safety-related defects have been detected.
- Immediately repair any damage. Escaping compressed air can cause injury.
- Depressurise system and pressure lines before beginning repair work.
- Pressurised air lines must be laid and mounted by qualified personnel. Connections must not be mixed up. Fittings, length and quality of the piping must correspond to requirements.
- Adjustment, maintenance and inspection activities and keep appointments, including information on replacement parts / equipment, prescribed in the operating instructions have to be respected.
- If the machine / equipment is completely off during maintenance and repair work, it must be protected against unexpected restart. Turn off main control device and remove the key and/or display a warning sign on the main switch.
- The machine and especially the connections and fittings should be cleaned from oil, fuel and maintenance products at the beginning of the maintenance / repair. Do not use aggressive cleaning agents. Use fibre-free cleaning cloths.
- Switch off compressor and clean with a slightly damp cloth. Remove dirt from cooling pipes by using a brush.
- After cleaning, examine all pipes for leaks, loose connections, chafing and damage. Immediately eliminate any faults.
- Always retighten any screw connections loosened for maintenance or repair work.
- If it is necessary to remove safety devices for maintenance and repair work, these must be replaced and checked immediately after completion of the maintenance or repair work.
- The electrical equipment of the compressor must be regularly checked. Defects, such as loose screw connections or burnt wires, must be immediately rectified by electrically skilled personnel.
- Only personnel with particular knowledge and experience with pneumatics may carry out work on pneumatic equipment.
- Only personnel with particular knowledge and experience in gas equipment may carry out work on gas equipment.

A



## **SAFETY PRECAUTIONS**

---

### **Transportation instructions**

- Parts which need to be dismantled for transport purposes must be carefully replaced and secured before taking into operation.
- The transport may only be carried out by trained personnel.
- For transportation, only use lifting devices and equipment with sufficient lifting power.
- Do not stand or work under suspended loads.
- Also separate from minor relocation machinery / system of any external energy supply. Before recommissioning, reconnect the machine to the mains according to regulations.
- When recommissioning, proceed according to the operating instructions..

### **Safety regulations**

- Inspections according to legal and local obligatory regulations regarding accident prevention are carried out by the manufacturer or by authorised expert personnel. No guarantees whatsoever are valid for damage caused or favoured by the non-consideration of these directions for use.

**A**



A

# INSTALLATION

## INSTALLATION

### Installation in closed rooms



#### Danger

No operation in explosion-hazard areas.

The unit is not approved for operation in areas prone to explosion.

#### For installation in closed rooms, observe the following:

- Install the unit horizontally and level. The floor must be vibration-free and capable of taking the load of the system weight.
- The compressor room must be clean, dry, dust free and as cool as possible. Avoid direct exposure to sunlight. If possible, install unit in such a manner that the compressor fan can intake fresh air from outside. Ensure adequate ventilation and exhaust air opening.
- When locating the compressor in rooms of less than 30 m<sup>3</sup> space where natural ventilation is not ensured or other systems having high radiation are operating in the same room, measures must be taken to provide artificial ventilation.
- Intake air must be free from noxious gas e.g. smoke, solvent vapours, exhaust fumes etc.
- Observe the specified operating temperature (see "Technical Data")!



#### Note

The intake air must be free of harmful gases.

We recommend to use an intake hose in order to get fresh air from the outside.

#### Benchmarks - Diameter of the suction hose as a function of the suction hose length

Pos.	Length of suction hose [m]	Diameter suction hose [mm]
1	≤ 3	Ø 30
2	≤ 10	Ø 80
3	≤ 15	Ø 100
4	≤ 20	Ø 120



# INSTALLATION

## Dimensions

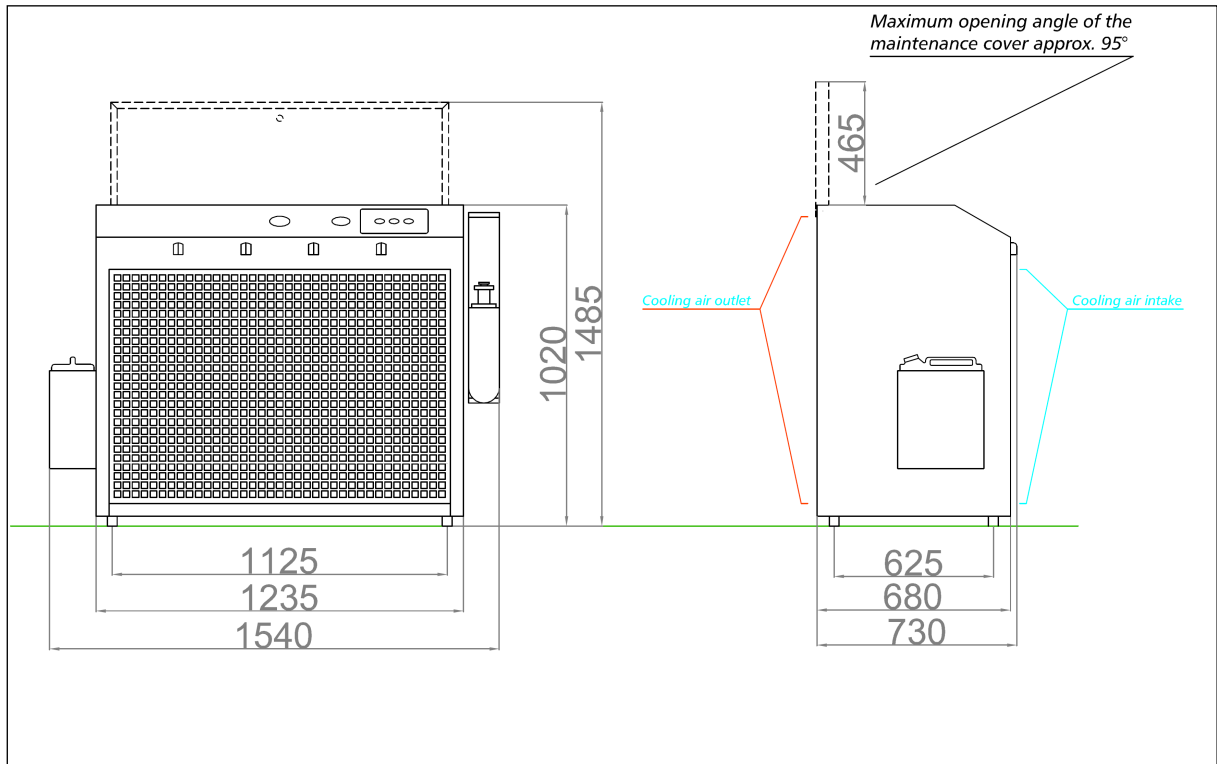

Fig. Dimensions

A

## INSTALLATION

### Minimum distances



#### Note

Minimum distances must be adhered!

- Make sure that the compressor always has a sufficient amount of fresh air available.
- To prevent serious damage, ensure that the cooling air flow can flow freely.
- The following minimum distances must be adhered:  
Front side min. 1500 mm, sides min. 500 mm, rear side min. 500 mm.  
Avoid anything in this area which can restrict the cooling air flow.

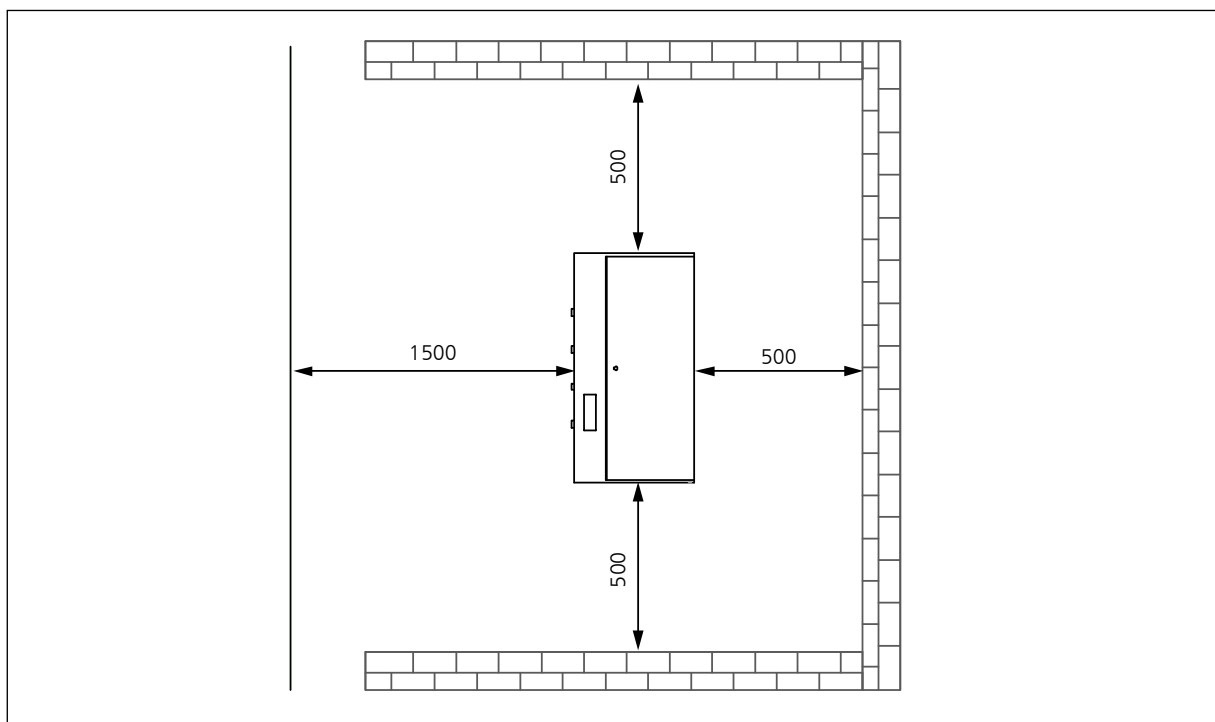

Fig. Minimum distances

## INSTALLATION

### Ventilation

- Make sure that the compressor always has a sufficient amount of fresh air available for cooling.
- To prevent serious damage, ensure that the cooling air flow can flow freely.
- The necessary cooling air flow can be calculated by using the following formula:  
 $300 \times \text{drive power [kW]} = \text{required cooling air flow [m}^3/\text{h]}$   
 Example 11kW motor:  $300 \times 11\text{kW} = 3300 \text{ m}^3/\text{h} = \text{required cooling air flow.}$
- The fan capacity for fresh air and warm air must meet at least the required cooling air flow.  
 The fans must have the same capacity.

A

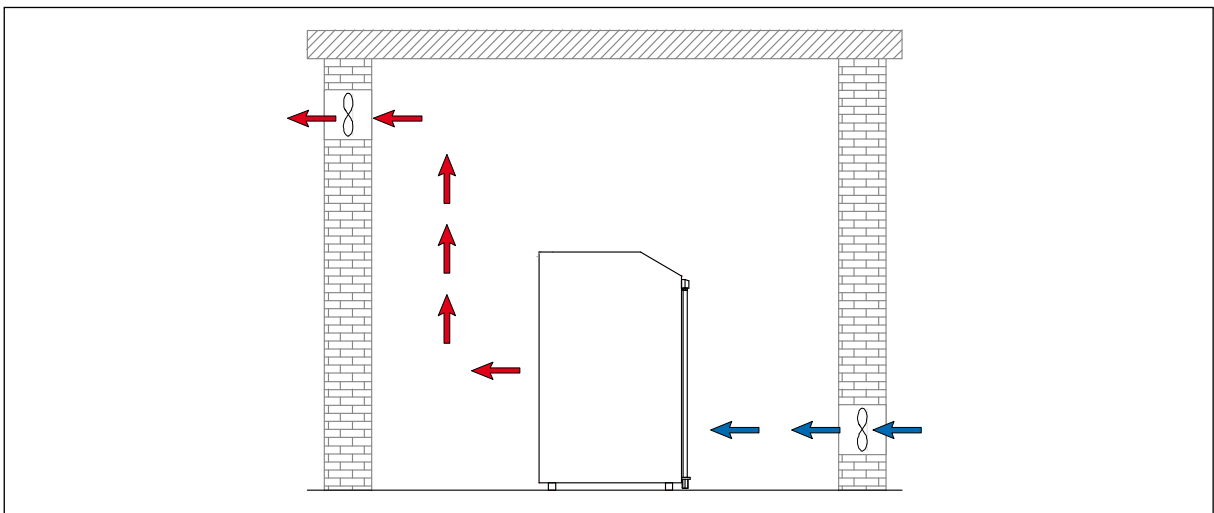

Fig. Ventilation through facade

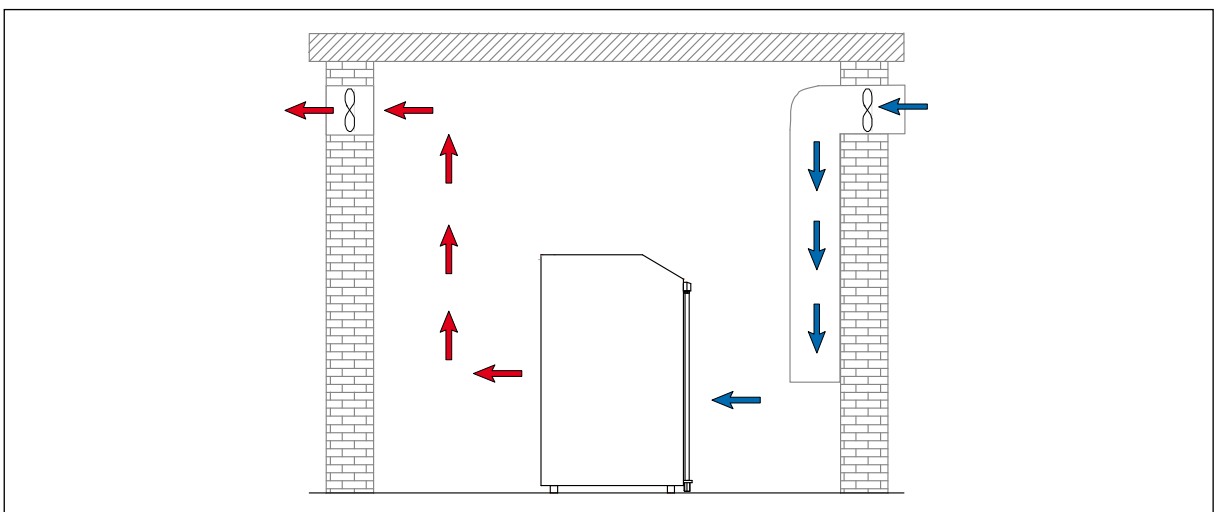

Fig. Ventilation via ventilation stack

## INSTALLATION

### Electrical Installation



#### Warning

Work on the electrical equipment on / with the machine / unit may only be carried out by qualified electricians.

For installation of electrical equipment, observe the following:

- If control devices are delivered by the factory, refer to the appropriate wiring diagram.
- Ensure correct installation of protective conductors.
- Check conformity of motor and control device tension and frequency with those of the electric network (see name plate on the compressor).
- The fusing should be done in accordance with the valid regulations of the responsible electricity supply company.
- When connecting the unit to the electrical supply, check the compressor direction of rotation (see chapter "Maintenance" -> Check turning direction).
- Fuse the motor correctly (see table; use slow-blow fuses).

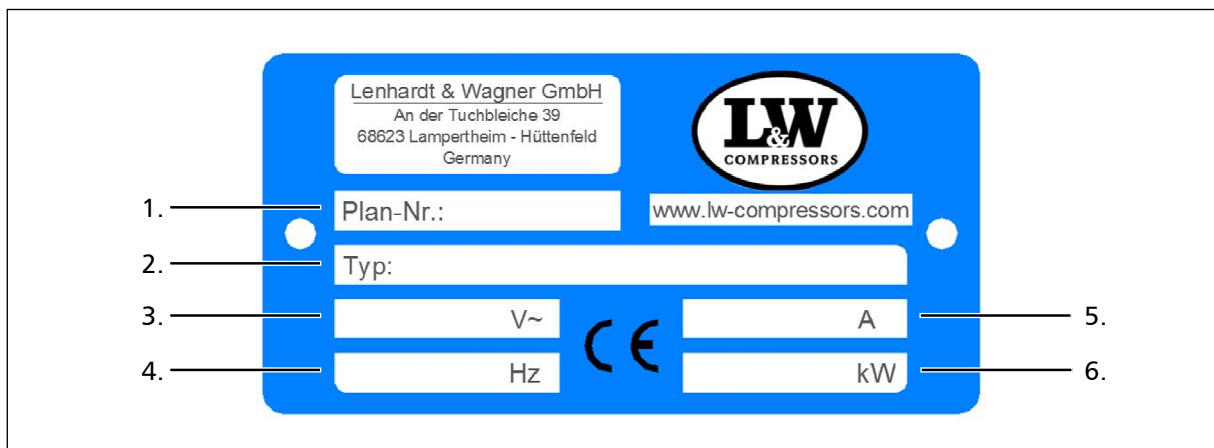

Fig. Compressor name plate

No.	Designation
1.	Circuit diagram number
2.	Compressor type
3.	Power supply
4.	Frequency
5.	Motor current consumption
6.	Nominal motor power

## INSTALLATION

### Electrical Installation

The standard compressor version is prepared for the connection to three phases (brown, black, grey), neutral conductor (blue) and protective earth conductor (green/yellow).

Fig. - Connection to the switch box

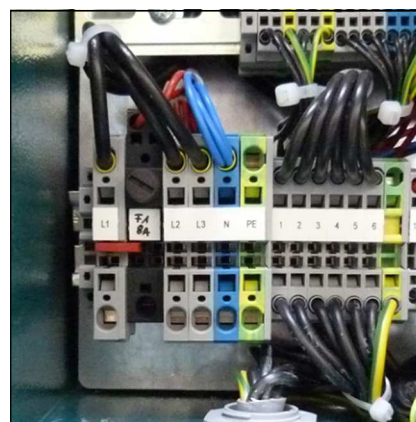

A

### Recommended fuses for 360 - 500 V operating voltage

Nominal motor power		Fusing start A		Connection in mm <sup>2</sup>	
[kw]	[A]	Direct	Star/Delta	Contactor supply	Motor S/D
2.2	5	10	-	1.5	1.5
4	8.5	20	-	2.5	1.5
5.5	11.3	25	20	2.5	1.5
7.5	15.2	30	25	2.5	1.5
11	21.7	-	35	4	2.5
15	29.9	-	35	6	4
18.5	36	-	50	6	4
22	41	-	50	10	4
30	55	-	63	10	6

### Recommended fuses for 220 - 240 V operating voltage

Nominal motor power		Fusing start A		Connection in mm <sup>2</sup>	
[kw]	[A]	Direct	Star/Delta	Contactor supply	Motor S/D
2.2	8.7	20	-	1.5	1.5
4	14.8	25	-	2.5	1.5
5.5	19.6	35	25	4	2.5
7.5	26.4	50	35	6	4
11	38	-	50	6	4
15	51	-	63	10	4
18.5	63	-	80	16	6
22	71	-	80	16	6
30	96	-	125	25	10



A

# OPERATION

## OPERATION

---

### Important operation instructions



#### Note

Ensure that all persons handling the compressor are familiar with function and operation of the unit.



#### Wear hearing protection

When working on a running machine, always wear hearing protection.

A

## FIRST COMMISSIONING

---

### Prior to first commissioning, observe the following:

Necessary steps are described on the next page.

- Ensure that cooling air can flow freely.
- Check compressor oil level by the oil sight glass (see next page).
- Check all connections and retighten if necessary.
- Check if the filter cartridge is in place (see "Service and Maintenance").
- Check the V-belt tension (see next page).
- Check if all filling valves are closed. Open one filling valve and hold tight manually!

### Start the compressor

1. Start the compressor by pushing the ON button.
2. Check turning direction - see the rotary direction arrow on the housing of the electric motor (see next pages). If the turning direction is wrong, immediately stop the compressor by pushing the OFF button and contact an authorised electrician.



#### Warning

Wrong impeller rotation direction!

Immediately after switching the compressor on, check the rotation direction. Depending on the place of installation, the phase sequence can influence the rotation direction.

3. Check oil pressure (if oil pressure gauge is installed).
4. Run the compressor for about 2 minutes.
5. Close the open filling valve carefully.
6. Run the compressor up to maximum pressure and check if the final pressure switch shuts off the compressor. If the final pressure switch does not shut off, switch off the compressor with the OFF button (see chapter "REMEDYING FAULTS").
7. Check the compressor unit for leaks (see "SERVICE AND MAINTENANCE")
8. Now check the condensate drain valves:
  - Fix the black condensate hoses
  - Drain test - press the test button
  - If correct, air escapes
9. Stop the compressor by pushing the OFF button.
10. Open all filling valves carefully to vent.



## FIRST COMMISSIONING

### Check oil level



#### Warning

Check oil level daily. Never start the compressor with a too low oil level. Risk of accidental loss, destruction or deterioration.

Check oil before each operation of the system!

The oil level should be between the middle and upper end of the oil sight glass. Never start the compressor with a too low oil level.

Refill new compressor oil at least when the oil level reached the middle of the indicated area.

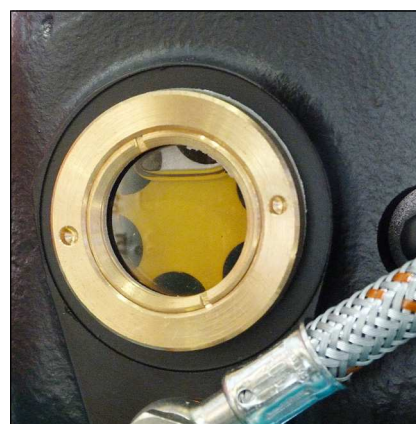

Oil sight glass

### Check V-belt tension

The V-belt could lose tension during transportation. Please check the V-belt tension before starting the compressor.

#### Tension V-belt

To tighten V-belt tension, loosen 4 mounting nuts of the drive motor. Use the tensioning screw to move the electric motor until the V-belt tension is sufficient. Then, tighten mounting nuts and check V-belt tension.

We recommend using a V-belt tension gauge.

#### Correct V-belt tension

Do not tension V-belt too tight. This damages bearings of compressor and motor. The V-belt should only be tensioned until there is no noise caused by slipping during start.

### Settings

Motor Type	Initial Installation	Operation after running in
Electric motors 50Hz	600 N	450 N
Electric motors 60Hz	500 N	400 N

## FIRST COMMISSIONING

### Check turning direction



#### Warning

Wrong impeller rotation direction!

Immediately after switching the compressor on, check rotation direction. Depending on the place of installation, the phase sequence can influence the rotation direction.

Before starting the compressor for the first time, check rotation direction (see the rotary direction arrow on the housing of the electric motor).

If the direction of rotation is wrong, the guide pistons of the 2nd and 3rd stages can not be sufficiently lubricated, with the consequence that the pistons will be damaged. Furthermore, cooling air flow will not be sufficient.

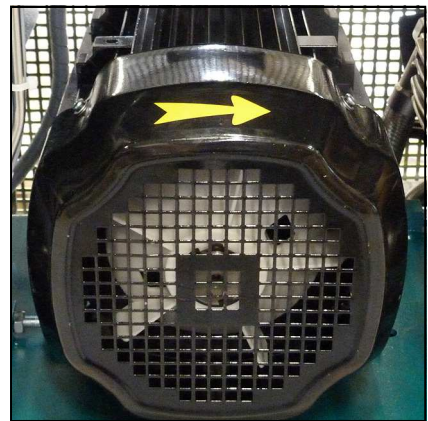

Rotation direction arrow

A



## DAILY COMMISSIONING

---

### **Prior to daily operation observe the following:**

- Ensure cooling air can flow freely.
- Check compressor oil level by the oil sight glass.
- Check if filter cartridge is in place / observe filter cartridge life!
- Ensure toxic-free, pure intake air.

A

## OPERATION

---

### Filling procedure



**Caution! Fill only cylinders which:**

- are marked with the test mark and the test stamp of the expert.
- have been hydrostatic tested (check last test date).
- are rated for the final pressure.
- are free from humidity.



**Note**

The unit shuts down when final pressure is reached. Thus, the unit always has to be restarted manually.

1. Close all filling valves.
2. Connect the closed compressed air cylinders.
3. Open cylinder valves.
4. Start compressor by pushing the ON button.
5. When the filling pressure gauge increases, open the filling valves slowly.
6. Fill compressed air cylinders to the desired pressure, subsequently close the filling valves slowly.
7. Close and vent all filling valves.
8. Disconnect all compressed air cylinders from filling valves.

A



## OPERATION

---

### Switch off the compressor

The compressor unit is equipped as standard with a pressure switch which automatically shuts down the system when the corresponding final pressure is reached.

During filling process, you can shut down the system at any time by pushing the red button (OFF) or the emergency stop (only in case of emergency!).



#### Note

After automatic or manual switching off, all pressure vessels and filter housings of the compressor will be automatically vented.

A



A

# REMEDYING FAULTS

## REMEDYING FAULTS

### Final pressure can not be reached

Cause of fault	Remedy
Connections leaky	Retighten or clean/replace if necessary
Final pressure safety valve leaky	Replace
Pipes / heat exchanger broken	Replace
Condensate drain valves leaky	Unscrew valves, check sealing surfaces, clean, replace if necessary
Final pressure switch stop unit	Verify settings, replace if necessary
Piston of pneumatic condensate valve sticks	Clean pneumatic condensate valve and restore function, check/replace o-rings, replace valve completely if necessary

### Strong compressor vibration

Cause of fault	Remedy
V-belt tension too loose	Tension V-belt
Drive motor / Compressor unit loosely	Retighten mounting screws
Anti vibration mounts used up	Replace
Ground not levelled	Ensure a solid and level ground

### Air supply too low

Cause of fault	Remedy
Inlet and outlet valves contaminated / defective	Clean, replace if necessary
Cylinder(s), piston(s) or piston ring(s) used up	Replace
V-belt slips	Tension V-belt
See chapter "Final pressure can not be reached"	See chapter "Final pressure can not be reached"

## REMEDYING FAULTS

### Compressor overheated

Cause of fault	Remedy
Inlet filter cartridge contaminated	Replace
Ambient temperature too high	Improve room ventilation / Reduce operation times
Cooling air inlet and outlet insufficient	Observe minimum distances (see Installation Instructions)
Air intake hose too long	Reduce length of the air intake hose
Air intake hose diameter too small	Use a larger diameter
Wrong compressor rotation direction	Ensure correct phase rotation,
Inlet and outlet valves contaminated / defective	Clean, replace if necessary

### Safety valve leaks

Cause of fault	Remedy
Inlet and outlet valves of the following pressure stage defective	Clean, replace if necessary
Sinter filter of the following water separator blocked	Replace
Safety valve leaky	Replace

### Oil taste in the air

Cause of fault	Remedy
Mole carbon filter cartridge saturated	Replace
Compressor oil unsuitable	Use prescribed oil quality
Filter cartridge unsuitable	Use prescribed filter type
Cylinder(s), piston(s) or piston ring(s) defective	Replace



## REMEDYING FAULTS

### Automatic condensate drain defective

Cause of fault	Remedy
Solenoid coils defective	Replace
Cable / supply cable defective	Repair, replace if necessary
Timer / relais defective	Replace
Sinter filter of pneumatic condensate valve blocked	Replace
Piston of pneumatic condensate valve sticks	Clean pneumatic condensate valve and restore function, check/replace o-rings, replace valve complete if necessary

### Condensate drain starts before reaching final pressure

Cause of fault	Remedy
Pressure stages are not as prescribed, control pressure of pneumatic condensate valve too low	Check corresponding inlet and outlet valve, replace if necessary.
Piston sealing of pneumatic condensate valve contaminated / used up	Clean, replace if necessary
Timer / relais settings not correct	Adjust as prescribed
Timer / relais defective	Replace

### Compressor stops before final pressure

Cause of fault	Remedy
Final pressure switch settings not correct	Correct settings
Opening pressure of the pressure maintaining valve too high	Correct settings
Fuse / circuit breaker has tripped Valid only for E models	Check fusing of the power supply / observe regulations
Emergency stop switch has tripped	Unlock emergency stop switch, close compressor housing door correctly



## REMEDYING FAULTS

### Filter life not sufficient

Cause of fault	Remedy
Pressure maintaining valve settings not correct	Adjust as prescribed
Filter cartridge unsuitable	Replace by a prescribed filter cartridge type
Filter cartridge too old	Observe expiration date
Filter cartridge packaging incorrect / damaged / already opened. Filter cartridge already partly saturated before change	Store filter cartridges properly, dispose defective cartridges
Operating temperature too high	Ensure sufficient ventilation
Cylinder(s), piston(s) or piston ring(s) defective	Replace

### Oil consumption too high

Cause of fault	Remedy
Cylinder(s), piston(s) or piston ring(s) defective	Replace
Compressor oil unsuitable	Use prescribed oil quality
Operating temperature too high	Observe prescribed operating temperatures
Oil leak at the compressor block	Tighten corresponding mounting screws, if necessary replace corresponding paper sealing / o-ring / shaft seal

A



A

# MAINTENANCE AND SERVICE

## MAINTENANCE AND SERVICE

---

### Service, Repair and Maintenance

Carry out service and maintenance work exclusively when the compressor is stopped and depressurised. The unit should be leak-checked regularly. Leaks can be preferably localised by using a leak detector spray (if necessary, brush pipes with soapy water).

We recommend that only authorised L&W service technicians carry out service work on the bearing of the compressor (crankshaft and connecting rods).

We urgently recommend that all maintenance, repair and installation work must only be carried out by trained personnel. This is necessary because all maintenance work can not be explained exactly and detailed in this manual.

Only use authentic spare parts for service work.



#### **Danger**

Components under pressure, such as hose ends, can quickly come loose when manipulated and can cause potentially fatal injuries due to the pressure surge. Any work on system parts may only be performed in a pressure-compensated state.



#### **Warning**

The use of accessories that have not been tested can lead to death or serious injury or damage to the unit. Only use authentic spare parts for service work.



#### **Warning**

Carry out maintenance or service work when the unit is switched off and protected against unexpected restart.



#### **Warning**

Risk of burns!

Carry out maintenance or service work when the unit has cooled down.



## MAINTENANCE AND SERVICE

### Daily before taking unit into operation

Maintenance work	Type	Quantity	Order No.
Check oil level	-	-	000001
Check condition of all filling hoses	-	-	-
Check filter cartridge lifetime	-	-	-
Operate unit to final pressure and check function of final pressure switch	-	-	-

### At 25 operation hours

Maintenance work	Type	Quantity	Order No.
Oil change	-	2,7	000001
Replace oil filter cartridge	-	1	009446

### Every 3 months or as required

Maintenance work	Type	Quantity	Order No.
Check/Retorque all connections and bolts	-	-	-
Open solenoid valve at the 1.7ltr filter housing, drain condensate if necessary	-	-	-

## MAINTENANCE AND SERVICE

### Annually

Maintenance work	Type	Quantity	Order No.
Oil change, if less than 1000 operating hours	-	2.7	000001
Replace Oil Filter Cartridge, if less than 1000 operating hours	-	1	009446
Check V-belt tension and condition	LW 300 E III (50Hz)	1	-
	LW 300 E III (60Hz)	1	-
	LW 450 E III (50Hz)	1	011036
	LW 450 E III (60Hz)	1	-
Check opening pressure of final safety valve	-	-	-
Clean coolers	-	-	-
Clean all oil/water separators, if less than 500 operating hours	-	-	-
Service intake filter (depends on condition - if less than 500 operating hours)	-	-	-
Check all connections for leakage	-	-	-

### Every 500 operating hours

Maintenance work	Type	Quantity	Order No.
Change intake filter *	-	1	000170
Check pressure maintaining/non-return valve	-	-	-
Check V-belt tension and condition	LW 300 E III (50Hz)	1	-
	LW 300 E III (60Hz)	1	-
	LW 450 E III (50Hz)	1	011036
	LW 450 E III (60Hz)	1	-



#### \* Note

Article is part of our 1000h, 2000h and 4000h service kits.

## MAINTENANCE AND SERVICE

### Every 1000 operating hours (latest in 5 years)

A

Maintenance work	Type	Quantity	Order No.
Replace sintered metal filter element of water separators	1st stage	1	000184
	1st stage	1	002914
	2nd stage	1	000173
	2nd stage	1	002914
Replace o-rings of water separators	1st stage	1	001294
	1st stage	2	001272
	2nd stage	3	001272
Replace o-ring of condensate stop valve	-	2	001264
Replace sintered metal filter of condensate stop valve housing	-	1	002914
Replace o-ring of condensate stop valve housing	-	1	006382
Replace sintered metal filter of pneumatic condensate valve	-	1	000188
Replace sintered metal filter of solenoid valve (350bar)	-	1	003159
Replace oil sieve	-	1	009545
Replace oil pump cover gasket	-	1	009546
Replace oil filter cartridge	-	1	009446
Oil change	-	2.7	000001
Replace o-rings of the filter housing 1.7ltr	-	2	001287
Replace back-up rings of the filter housing 1.7ltr	-	2	001285
Replace filter of 0.8l filter housing 0.8ltr	-	1	003980
Replace o-ring of the filter housing 0.8ltr	-	1	004221
Replace back-up ring of the filter housing 0.8ltr	-	1	004222
Replace filter of condensate-catch-tank	-	1	006462
Replace o-ring of condensate-catch-tank	-	1	002152



#### Note

All stated quantities are parts of our 1000h and 4000h service kits. You can find an overview on page Service Kits.

## MAINTENANCE AND SERVICE

### Every 4000 operating hours (latest in 10 years)

A

Maintenance work	Type	Quantity	Order No.
Replace all o-rings and gaskets of 1st, 2nd and 3rd stage	O-ring	3	008874
	O-ring	1	001274
Replace all inlet and outlet valves incl. gaskets	1st stage	1	000259
	2nd stage	1	000256
	3rd stage	1	010337
	Upper gasket 1st	1	000257
	Upper gasket 2nd	1	000254
	Lower gasket 1st	1	000258
	Lower gasket 2nd	1	000253
	Replace needle bearing for conrod	2nd stage	1
Replace needle bearing for conrod	3rd stage	1	003281



#### Note

All stated quantities are parts of our 2000h and 4000h service kits. You can find an overview on page Service Kits.



## MAINTENANCE AND SERVICE

### Service Kits

The service kits contain parts for maintenance according to the factory requirements.

The use of the service kits ensures that all required parts are ordered and replaced and gives assurance that all parts are included in the order. Depending on the model and interval, the service kits include parts such as O-Rings, Sinter Filter, Inlet Filter, Silencers, In-&Outlet Valve, Valve Seals and Compressor oil.



Service Kits

A

### Service Kits LW 300 E III / LW 450 E III

Compressor	Operating Hours	Order No.
LW 300 E III	1000 h	009718
LW 300 E III	4000 h	010444
LW 450 E III	1000 h	009718
LW 450 E III	4000 h	010444



#### Note

V-belts are not included in our 1000h and 4000h service kits.



## MAINTENANCE AND SERVICE

---

### Check V-belt tension

The V-belt could lose tension during transportation. Please check the V-belt tension before starting the compressor.

### Tension V-belt

To tighten V-belt tension, loosen 4 mounting nuts of the drive motor. Use the tensioning screw to move the electric motor until the V-belt tension is sufficient. Then, tighten mounting nuts and check V-belt tension.

We recommend using a V-belt tension gauge.

### Correct V-belt tension

Do not tension V-belt too tight. This damages bearings of compressor and motor. The V-belt should only be tensioned until there is no noise caused by slipping during start.

### Settings

Motor Type	Initial Installation	Operation after running in
Electric motors 50Hz	600 N	450 N
Electric motors 60Hz	500 N	400 N

## MAINTENANCE AND SERVICE

### Compressor lubrication

The following parts get lubricated by a mechanical oil pump (gear type, directly driven by crankshaft):

- crankshaft roller bearing (oil pump side)
- big end bearings
- guide cylinder (3rd stage)

Additional lubrication by splash oil on:

- crankshaft bearing (flywheel side)
- 1st and 2nd stage cylinders

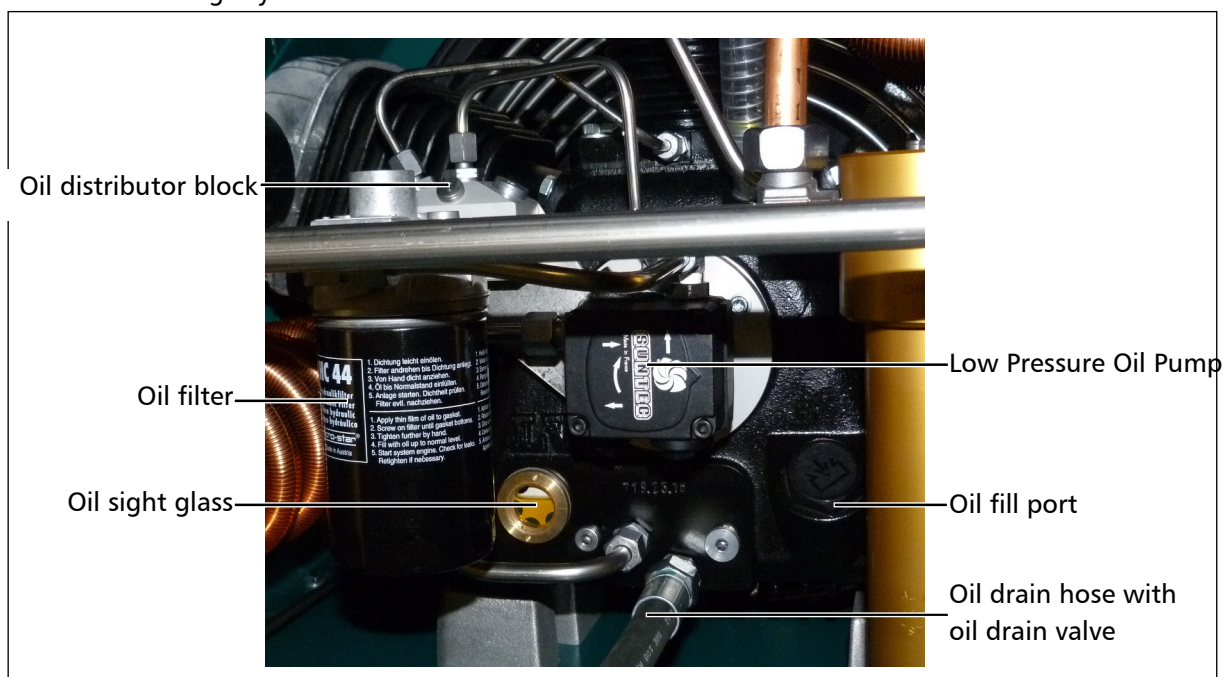

Lubricating System

### Check oil level



#### Warning

Check oil level daily. Never start the compressor with a too low oil level. Risk of accidental loss, destruction or deterioration.

Check oil before each operation of the system!

The oil level should be between the middle and upper end of the oil sight glass. Never start the compressor with a too low oil level.

Refill new compressor oil at least when the oil level reached the middle of the indicated area.

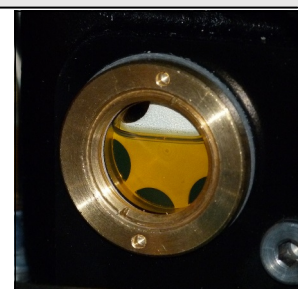

Oil sight glass

## MAINTENANCE AND SERVICE

---

### Oil change



#### Note

We recommend oil change at least once a year - depending on total operating hours.

A

#### Oil change as follows:

- Run compressor warm for approx. 2 min.
- Switch off and vent compressor. Secure against restarting
- Place a suitable oil drain tray under the drain hose and oil filter.
- Open carefully oil drain valve and drain oil completely.
- Close oil drain valve.
- Change oil filter cartridge with a suitable oil filter key (Part number 009728)  
Pre-fill the new oil filter cartridge with 400 ml synthetic compressor oil
- Loose oil fill port with an appropriate adjustable wrench (AF 0-40 mm) and unscrew manually.
- Fill oil by using a funnel.
- Check oil level. The oil level should be between the middle and upper end of the oil sight glass.
- Screw oil fill port manually in and tighten with the adjustable wrench.

The oil change is now completed.

#### Maintenance intervals

- First oil- and oil filter change 25 operating hours (total hours).
- All further changes after each 1,000 operating hours.

#### Oil and oil capacity

Approx. 2,700 ml synthetic compressor oil is necessary for one oil change. Only use synthetic compressor oil which is recommended as suitable from L&W.

## MAINTENANCE AND SERVICE

---

### Oil sieve change

Oil sieve change as follows:

- Loosen cover screws (4 pcs).
- Remove the cover, the cover gasket and the oil sieve.
- Clean the oil sieve with petroleum-ether or replace the defective oil sieve.
- Replace by a new or cleaned oil sieve.
- Replace the new gaskets.
- Soak the gaskets with oil before placing (respect mounting direction).
- Remount the cover with the 4 cover screws. Tightening torque: 4.5 - 8 N.

The oil sieve change is now completed.

### Maintenance intervals

- We recommend cleaning or replacing the oil sieve every 1,000 working hours.
- 009545—Oil sieve, 009546—oil pump cover gasket

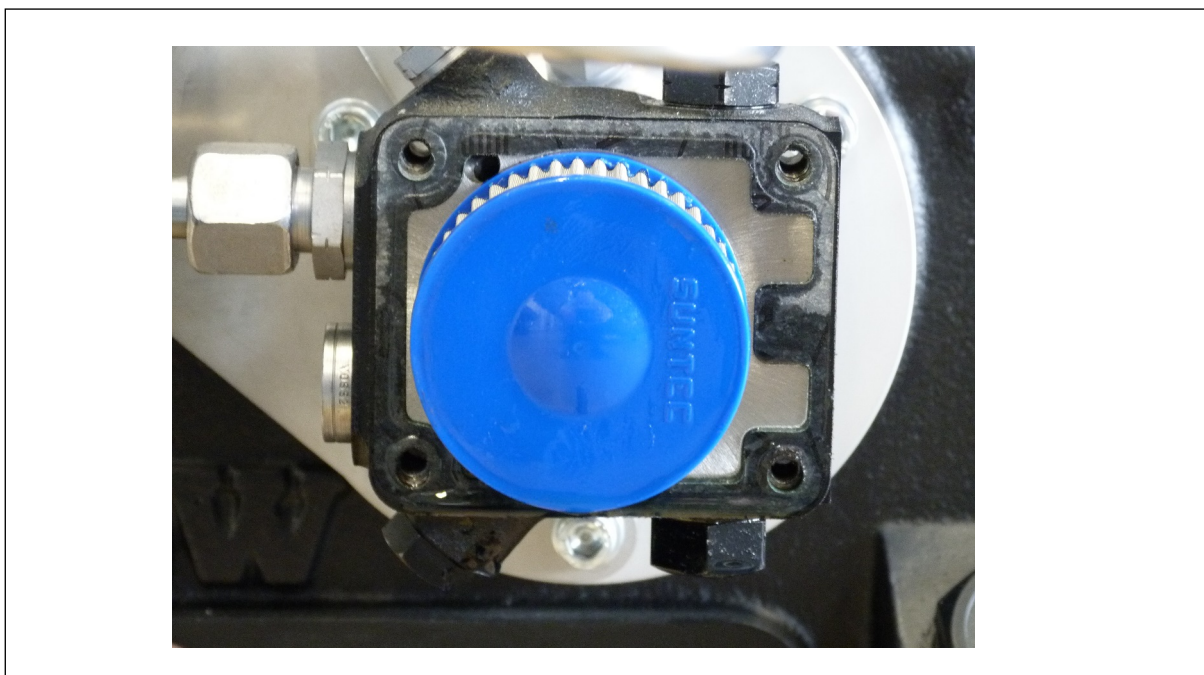

Correct cover gasket mounting direction

### Final pressure switch



**Note**

Do not adjust the final pressure switch to the safety valve pressure. The final pressure switch has to be adjusted to min. 10 bar below the safety valve pressure. Otherwise, the safety valve can open during operation. This considerably reduces the life of the safety valve.

The pressure switch shuts off the compressor automatically when the selected final pressure is reached. The final pressure switch is already adjusted to the corresponding cut-out pressure.

The pressure can be adjusted with the upper adjusting screw as follows:

**Increasing cut-out pressure:**

Turn the adjusting screw clockwise

**Reducing cut-out pressure:**

Turn the adjusting screw anti-clockwise

Adjust the pressure switch in steps of a quarter turn. Restart the compressor after every adjustment step to verify the actual cut-out pressure.

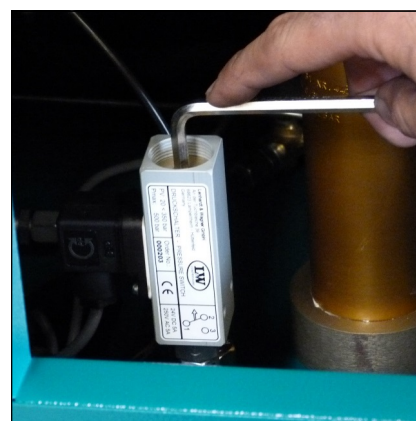

Final pressure switch

**Example settings:**

Safety valve	Max. Operating Pressure
225 bar	215 bar
250 bar	240 bar
330 bar	320 bar

### Automatic condensation dump system



#### Note

The collected condensate can contain oil and has to be disposed according to regulations.

The LW 450 E III comes as standard with an automatic condensation dump system. Solenoids drain all condensate separators every 15 minutes.

To test the system, press the blue condensate test drain button on the operating panel.

### Oil / water separators

Condensate is separated after every stage of compression. All three oil / water separators are equipped with electronic timer controlled solenoids. The timer is located in the switch box and activates the dump valves about every 15 minutes.

The condensate drains through the black plastic hoses into the 10 liter condensate catch tank.

The drain noise can be kept to a minimum by using a silencer.

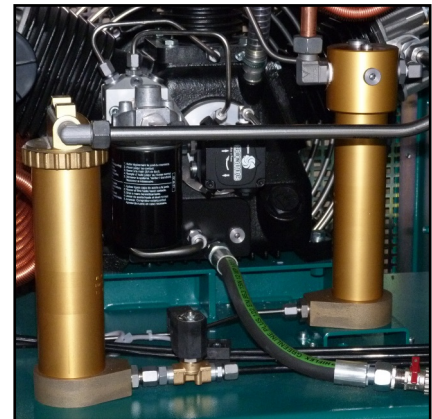

### Maintenance intervals

We recommend to clean oil and water separators every 500 operating hours or at least once a year, to check for corrosion damage and to replace o-rings if necessary.

All oil / water separators have an integrated sinter filter which has to be replaced every 1,000 operating hours.



Condensate Catch Tank 10 Litre



### Oil / water separator 1st stage - maintenance



#### Note

Clean all parts thoroughly before assembly.

#### Change / clean oil / water separators 1st stage as follows:

- Loosen pipes and mounting screws.
- Remove oil / water separators.
- Open ring nut and remove separator top (Fig. 1).
- Open nut and remove separator top (Fig. 2).
- Change sinter filter (Fig. 3).
- Reassemble all parts and tighten nut.
- Change o-ring, previously grease new o-ring (Page 51, Fig. 4).
- Place separator top and tighten ring nut manually.
- Remove the base ring (Page 51, Fig. 5).
- Change o-rings, previously grease new o-rings (Page 51, Fig. 6).
- Remove the connection of the base ring and change the sinter filter (Page 51, Fig. 7).
- Reassemble the connection.
- Mount the base ring.
- Mount oil / water separator.
- Tighten pipes and mounting screws.

**Oil / water separator maintenance is now completed.**



Fig. 1 - Open ring nut and remove separator top



Fig. 2 - Loosen nut at the separator top

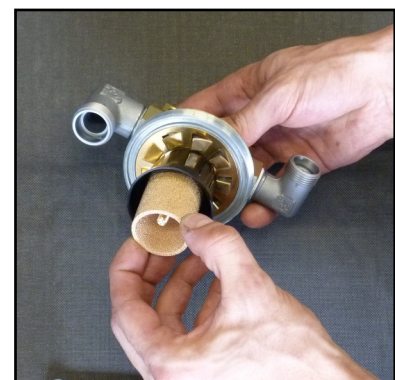

Fig. 3 - Change sinter filter



**Oil / water separator 1st stage - maintenance - continued from previous page**

**A**

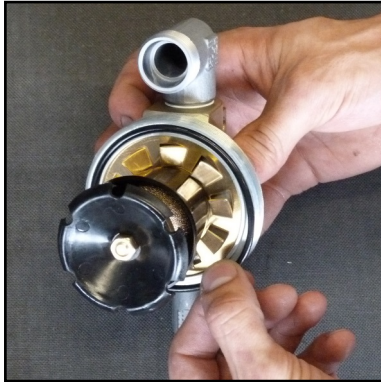

Fig. 4 - Change o-ring



Abb. 5 - Remove the base ring



Abb. 6 - Change o-rings

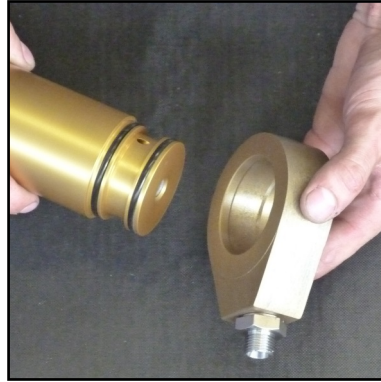

Abb. 7 - Change sinter filter

### Oil / water separators 2nd stage - maintenance



#### Note

Clean all parts thoroughly before assembly.

#### Maintenance / cleaning of oil / water separators 2nd stage as follows:

- Loosen pipes and mounting screws.
- Remove oil / water separators.
- Unscrew and remove filter top (Fig. 1).
- Open nut of separator top (Fig. 2).
- Change sinter filter (Fig. 3).
- Reassemble all parts and tighten nut.
- Pull the condensate stop valve out of the filter housing by using a threaded rod
- Change o-ring, previously grease new o-ring (Page 53, Fig. 4).
- Push the condensate stop valve into the filter housing by using a threaded rod.
- Change o-ring on the top of the filter housing, previously grease new o-ring (Page 53, Fig. 5).
- Place separator top and tighten manually.
- Remove the base ring (Page 53, Fig. 6).
- Change o-rings, previously grease new o-rings (Page 53, Fig. 7).
- Remove the connection of the base ring and change the sinter filter (Page 51, Fig. 8).
- Reassemble the connection.
- Mount the base ring.
- Mount oil / water separators.
- Tighten pipes and mounting screws.

The oil / water separator maintenance is now completed.



Fig. 1 - Unscrew and remove filter top

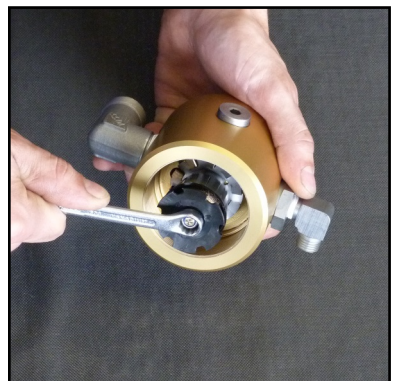

Fig. 2 - Loosen nut at the separator top

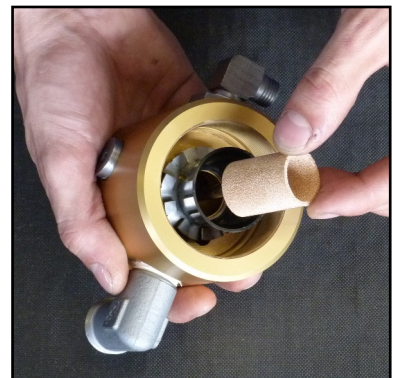

Fig. 3 - Change sinter filter

**Oil / water separators 2nd stage - maintenance - continued from previous page**

**A**



Abb. 4 - Change o-ring



Abb. 5 - Change o-ring



Abb. 6 - Remove the base ring



Abb. 7 - Change o-rings



Abb. 8 - Change sinter filter



### Condensate stop valve - maintenance



#### Note

Clean all parts thoroughly before assembly.

#### Change/clean condensate stop valve as follows:

- Loosen pipes and mounting screws.
- Remove condensate stop valve housing.
- Remove allen bolts and pull off the cover by screwing two allen bolts into the threaded holes (Fig. 2).
- Pull the condensate stop valve out of the filter housing by using a threaded rod
- Change o-ring, previously grease new o-ring (Fig. 3).
- Push the condensate stop valve into the filter housing by using a threaded rod.
- Change o-ring of the cover, previously grease new o-ring (Fig. 4).
- Mount the cover, tighten the allen bolts crosswise.
- Remove the connection on the cover ring and change the sinter filter (Fig. 5).
- Reassemble the connection
- Mount condensate valve housing.
- Tighten mounting screws and pipes

The oil / water separator maintenance is now completed.



Fig. 1 - Condensate stop valve housing



Fig. 2 - Remove the cover



Abb. 3 - O-Ring wechseln  
(Kondensat-Stopp-Ventil)



Abb. 4 - O-Ring wechseln (Deckel  
Kondensat-Stopp-Ventil)

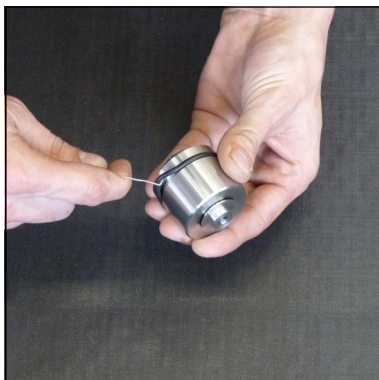

Abb. 5 - Sinterfilter wechseln

### Pneumatic condensate valve - maintenance



#### Note

Clean all parts thoroughly before assembly.

#### Pneumatic condensate valve change as follows:

- Loosen pipe connections and mounting screws.
- Remove pneumatic condensate valve.
- Loosen connection (Fig. 2).
- Change sinter filter (Fig. 3).
- Tighten horizontal screw.
- Mount pneumatic condensate valve.
- Tighten pipe connections and mounting screws.

**Pneumatic condensate valve maintenance is now completed.**

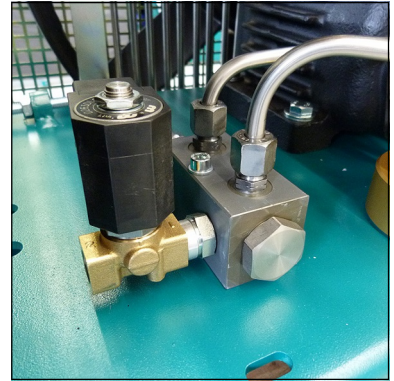

Pneumatic Condensate Valve

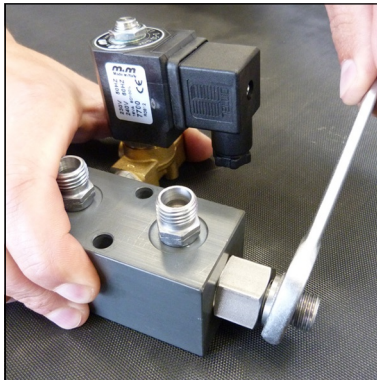

Fig. 2 - Loosen connection

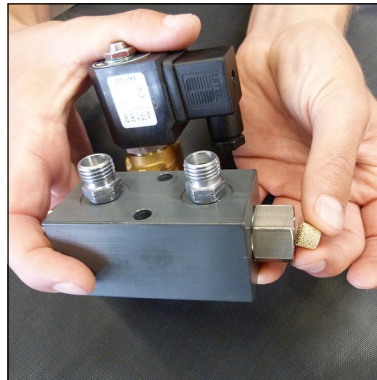

Fig. 3 - Change sinter filter

## MAINTENANCE AND SERVICE

### Filter housing 1.7 ltr

The mole carbon filter housing is installed on the right hand side of the compressor housing.

Inside the filter housing a jet blows air on to the housing wall. Condensation water and oil are led by centrifugal force to the bottom of the housing. Air flows through the mole carbon filter cartridge, which purifies the air from residual moisture and odours. The manual condensate drain valve needs to be opened if a drain is necessary and before filter cartridge change.

### Filter cartridge 1.7 ltr

The high-pressure compressor is equipped with an integrated breathing air purification system. Air is compressed up to 330 bar, dried and odour- and tasteless purified. Oil residues are bounded. The breathing air filter cartridge consists of a molecular sieve and activated-carbon filter.

Cartridge capacity: approx. 1.7 ltr

All breathing air filter cartridges are factory vacuum sealed.

We recommend unpacking the filter cartridges just before installation. Filter cartridges which are exposed too long could be saturated with moisture and become unusable.



Filterhousing 1.7l (right), and filter unit 0,8l with safety valve (left)

### Maintenance intervals

The life of the 1.7 ltr filter cartridge is substantially depend on the operating temperature, from the state of wear of the compressor, of the filter size and the operating pressure.

We recommend to monitor the state of the filter.

### Pre-Filter 0.8 ltr

In particle filter particles are filtererd out up to a size of 10  $\mu\text{m}$ . The pre-filter are separating water before final filter housing.

### Maintenance intervals

The life of the 0.8 ltr filter cardridge is substantially depend on the operating temperature, from the state of wear of the compressor, of the filter size and the operating pressure.

It needs to be cleaned annually and serviced when 1000h are reached. We recommend to monitor the state of the filter.

## MAINTENANCE AND SERVICE

### Filter cartridge change

Filter cartridge change as follows:

- Run the compressor up to a pressure of 100 bar.
- Stop compressor.
- Open filling valve.
- Unscrew filter housing cover by using the special filter tool (Fig. 1).
- Place the T-piece end of the filter tool in the recess of the filter cartridge (Fig. 2).
- Unscrew the filter cartridge anti-clockwise and pull the cartridge out of the housing (Fig. 3).
- Open the packing of the new filter cartridge and place it with the filter tool in the filter housing.
- Screw the new filter cartridge hand tight in by using the filter tool.
- Screw the cover of the filter housing first manually in.
- After it has been completely screwed in, turn cover anticlockwise for 90°. This avoids tightening of the cover due to vibration..

The filter cartridge change is now completed.



#### Note

Ensure that the old filter cartridge is disposed correctly at an approved waste point.



Fig. 1 - Unscrew the filter housing cover.



Fig. 2 - Place the T-piece end of the filter key in the top of the filter cartridge.



Fig. 3 - Pull the cartridge out of the housing.

A



### Filter housing - maintenance



#### Note

Clean all parts thoroughly before assembly.

#### Filter housing maintenance as follows:

- Open Filter Cover (Fig. 1).
- Change o-ring and back-up ring, previously grease both (Fig. 2).
- Grease filter cover thread and close.

#### Dismount filter housing

- Loosen pipe connections and nuts (Fig. 3).
- Remove filter housing.
- Dismount filter housing base.
- Change o-ring and back-up ring, previously grease both (Fig. 4).
- Screw filter base tight in.

#### Mount filter housing

- Connect pipe connections and tighten.
- Adjust holding clamp and tighten nuts.

The filter housing maintenance is now completed.



Fig. 1 - Open Filter cover

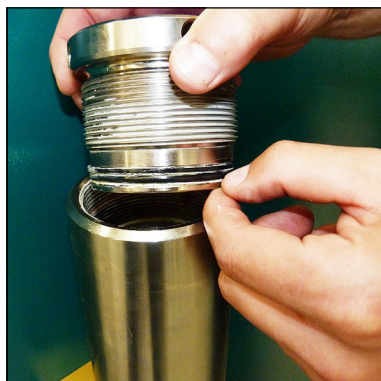

Fig. 2 - Change o-ring and back-up rings

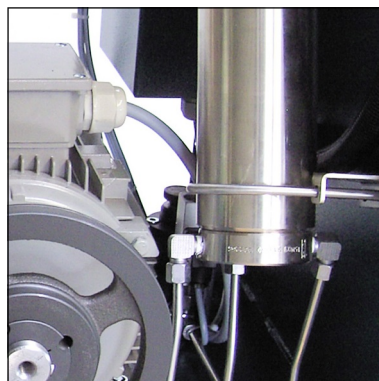

Fig. 3 - Loosen pipe connections and nuts



Fig. 4 - Change o-ring and back-up rings



## MAINTENANCE AND SERVICE

### 0.8ltr filter element change

Filter element change as follows:

- Start the compressor and run up to a pressure of 100 bar.
- Stop the compressor.
- Open vent tap to release pressure from 1.7l filter housing.
- Loosen pipe connections and mounting screws (Fig. 1 a. 2)
- Remove complete pre-filter housing.
- Open pre-filter cover (Fig. 3).
- Change the filter element (stuck in filter cover) (Fig. 4).
- Change o-ring, previously grease new o-ring .
- Grease thread of filter cover, o-ring and back-up ring.
- Reassemble pre-filter cover and filter housing. Note the correct position of the filter back-up!
- After you have screwed it completely, loosen the pre-filter cover about 90 °. This avoids a terminals of the pre-filter cover due to a hard shaking while operation.

The filter element change is now completed.



#### Note

Ensure that the old filter element is disposed correctly at an approved waste point.



Fig. 1 - Loosen pipe connections and mounting screws

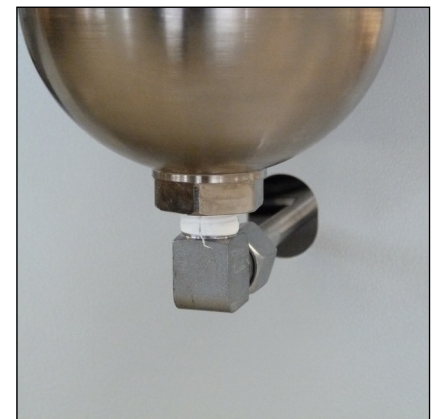

Fig. 2 - Loosen pipe connections and mounting screws

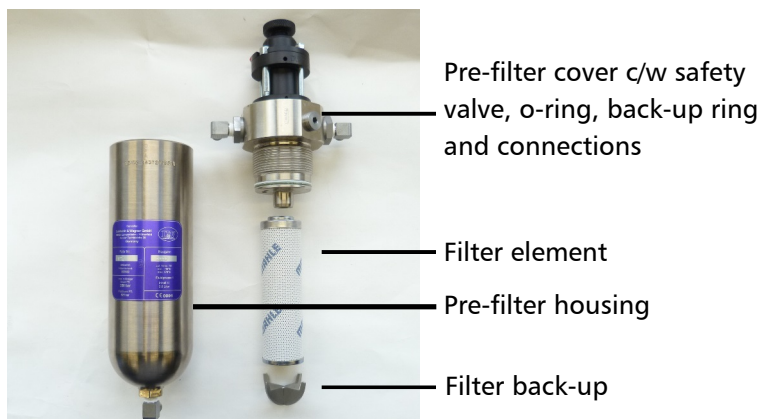

Fig. 4 - 0.8ltr pre-filter parts



Fig. 3 - Open pre-filter cover

### 0,8l Pre-filter housing - maintenance



#### Note

Clean all parts thoroughly before assembly.

#### Pre-filter housing maintenance as follows:

##### Dismount pre-filter housing

- Loosen pipe connections and nuts (siehe S.59, Abb. 1 u.2).
- Remove pre-filter housing.

##### Pre-filter housing maintenance

- Open pre-filter Cover (siehe S.59, Abb. 3).
- Change o-ring and back-up ring, previously grease both (Abb. 1)
- Screw filter base tight in

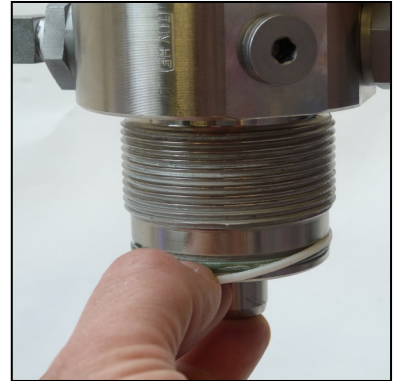

Fig. 1 - Change o-ring and back-up ring

##### Install pre-filter housing

- Connect pipe connections and tighten.
- Adjust holding clamp and tighten nuts

The pre-filter housing maintenance is now completed.

### Inlet Filters



#### Note

Dirty filters make intaking air difficult and reduce delivery capacity. Risk of compressor overheating.

A micro filter cartridge is used as an air inlet filter. Check air inlet filter regularly or replace if necessary. Defective air inlet filters should be immediately replaced.

### Maintenance Intervals

We recommend that the filter cartridge should be replaced every 1,000 working hours (depending on pollution grade).

### Inlet Filter Cartridge Change

Inlet filter cartridge change as follows:

- Loose nut (Fig.1)
- Remove cover and replace filter cartridge by a new one (Fig.2)
- Assemble intake filter
- Tighten nut

The inlet filter cartridge change is now completed.



(Fig.1) Loose nut

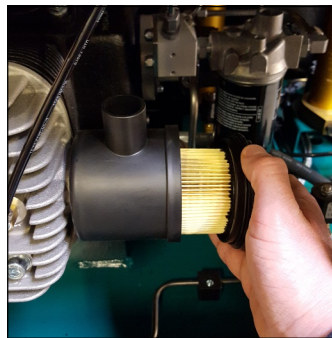

(Fig.2) Remove cover and replace filter cartridge

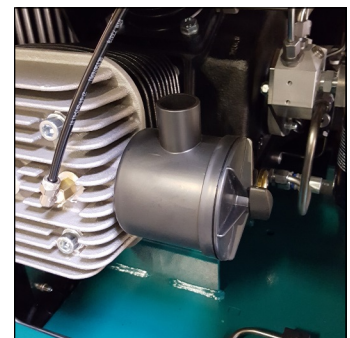

(Fig.3) Mount the intake filter

## MAINTENANCE AND SERVICE

---

### Cylinder heads and valves

Inlet and outlet valves of the specific compressor stages are located between valve head and cylinder. Outlet valves open while piston upstroke or compression stroke, inlet valves open while downstroke.

Valves are subject to normal wear and tear and have to be replaced at certain intervals (depending on specific operating conditions). Dismount valve heads to change valves. The three valves are combined inlet and outlet valves. The first and second stage valves are plate valves. The third stage contains a spring operated piston which acts inside a bronze cylinder.



Valve head 3rd stage

A

### Maintenance intervals

All valves should be replaced after 4,000 working hours due to normal wear and tear. To replace valves the cylinder heads have to be removed. There are no special tools required to replace these valves.

### Available special tools

Special tools are not necessary for dismounting inlet and outlet valves but make work easier.

Order number: 006847



Special tool

### Replace inlet and outlet valves 1st and 2nd stage



#### Note

The figures of the parts can differ due to the different stages.

Change inlet and outlet valves 1st and 2nd stage as follows:

#### Remove Inlet / Outlet Valve

- Loosen pipe connections
- Loosen valve head screws (Fig. 1)
- Remove valve head
- Pull out inlet and outlet valve (Fig. 2). CAUTION: Observe that the lower copper valve ring is also pulled out. (It can still stick inside the cylinder)
- Check valve head if defective

Install Inlet / Outlet Valve - see following page

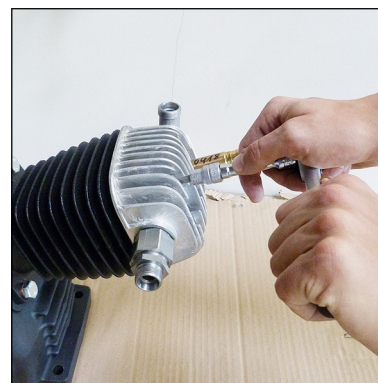

Fig. 1 - Loosen valve head screws



Fig. 2 - Pull out inlet and outlet valve



### Replace inlet and outlet valves 1st and 2nd stage - continued from previous page

A



#### Caution

The exact alignment of upper and lower valve gasket is very important. Inlet and outlet channels have to be exactly centred. Do not turn inlet and outlet valve after insertion. The copper valve ring could cover outlet channels.

#### Install Inlet / Outlet Valve

- Grease the lower valve gasket slightly and place on the new inlet and outlet valve.  
CAUTION: Observe correct copper valve ring position (centre inlet and outlet channels).
- Place the new inlet and outlet valve straightly into the cylinder (Fig. 3).  
CAUTION: Do not turn the inlet and outlet valve inside the cylinder! The copper valve ring could cover outlet channels!
- Place the upper valve gasket on the inlet and outlet valve.  
CAUTION: Observe the correct paper gasket position (centre inlet and outlet channels). (Fig. 4)  
Note: Valve head screws can be inserted into the valve head to secure the upper valve gasket.
- Refit the valve head and tighten the valve head screws cross-wise.

#### Starting torques:

1. nd Stage 45 Nm
2. nd Stage 30 Nm

The replacement inlet and outlet valves 1st and 2nd stage is now completed.

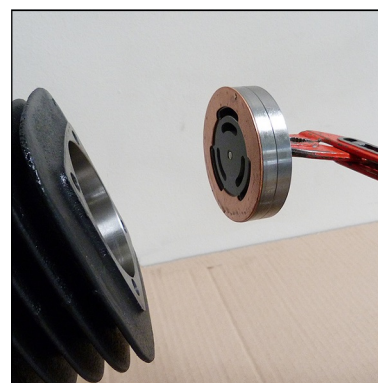

Fig. 3 - Place new inlet and outlet valve straightly into cylinder

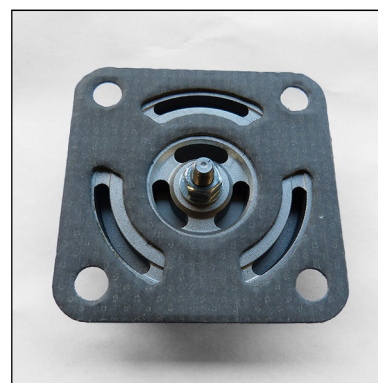

Fig. 4 - Ensure the correct mounting position of the paper gasket

## MAINTENANCE AND SERVICE

### Replacement inlet and outlet valves 3rd stage

Replacement inlet and outlet valves 3rd stage as follows:

- Loosen pipe connections
- Loosen valve head screws (Fig. 1)
- Remove lower valve gasket (Fig. 2)
- Dismount inlet and outlet valve (Fig. 3). Observe that the upper valve gasket is also pulled out. (It can still stick inside the cylinder head)
- Check valve head if defective (check centre pin)
- Mount valve gasket on inlet and outlet valve.  
CAUTION: Ensure correct mounting position of the upper valve gasket (Fig. 4).
- Insert new inlet and outlet valve into valve head.  
CAUTION: Observe correct position between valve centre hole and valve head centre pin.
- Place bottom valve gasket
- Place valve head with the new inlet and outlet valve. Tighten valve head screws crosswise (tightening torque 30 Nm).

Replacement inlet and outlet valves 3rd stage complete.

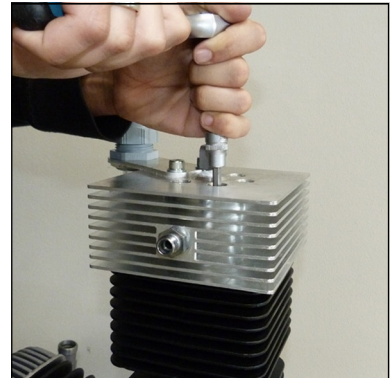

Fig. 1 - Loosen valve head screws



Fig. 2 - Remove lower valve gasket

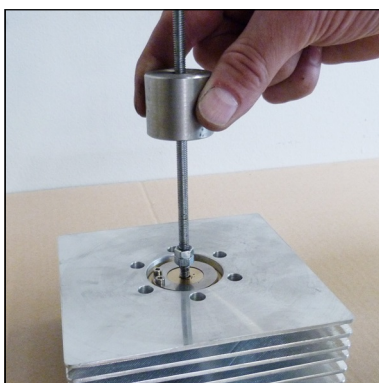

Fig. 3 - Remove inlet and outlet valve

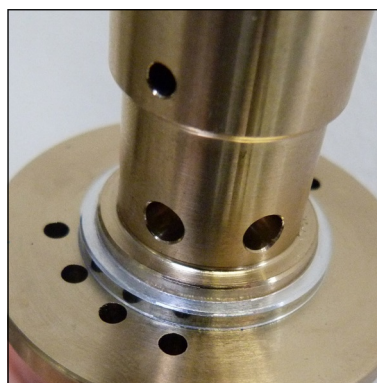

Fig. 4 - Ensure correct mounting position of the upper valve gasket

A

## MAINTENANCE AND SERVICE

### Replace piston rings and needle bearings of the 2nd and 3rd stage

Replace piston rings and needle bearings of 2nd and 3rd stage as follows:

- Remove in- & outlet pipework
- Remove valve head bolts
- Remove valve head
- Remove lower valve gasket (see "replace in- / outlet valves 2nd & 3rd stage")
- Check condition of valve head
- Remove flange nuts of compression cylinder
- Take off compression cylinder and o-ring
- Turn crankshaft until piston is on TDC position
- Remove piston rings
- Fit piston rings in accordance to drawing "piston 2nd / 3rd stage" and lubricate by using compressor oil.
- *Remove cylinder flange bolts (only necessary small end bearing needs to be replaced)*
- *Take-off guide cylinder*
- *Remove O-ring*
- *Clean sealing surfaces*
- *Remove circlips and piston pin, take-off piston*
- *Remove small end bearing by using L&W special tool (Part number: 006663 / 005456)*
- *Fit new small end bearing by using special tool , lubricate bearing*
- *Lubricate piston pin bore*
- *Fit piston to conrod, secure piston pin by circlips*
- *Lubricate and fit O-ring to guide cylinder*
- *Refit guide cylinder*
- *Tighten flange bolts crosswise*
- Lubricate and fit O-ring to compression cylinder
- Lubricate piston skirt
- Compress piston rings by using L&W special tool and pipe wrench. Refit compression cylinder

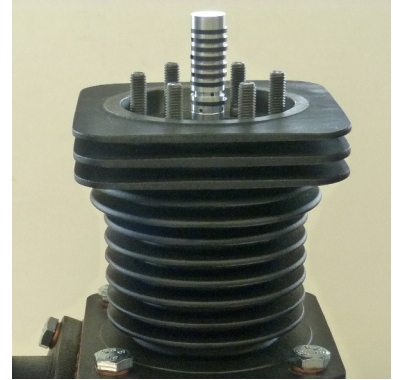

Fig. 1 - take off compression cylinder

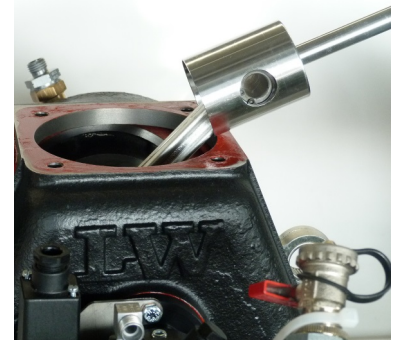

Fig. 2 - Piston 3rd Stage



**Change piston rings and needle bearings of the 2nd and 3rd stage - continue**

**A**

- Fit washers and nuts, tighten crosswise

See "In- / outlet valves 2nd and 3rd stage" for further instructions



Fig. 1 - fit circlip

**L&W special tool**

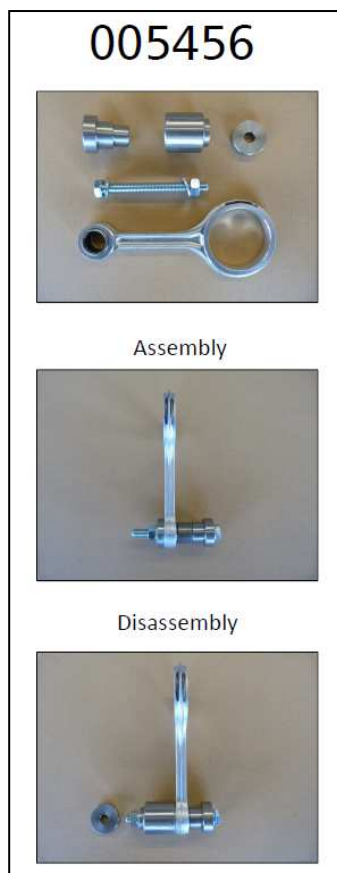

Fig. 2 - L&W special tool for 3rd stage 005456

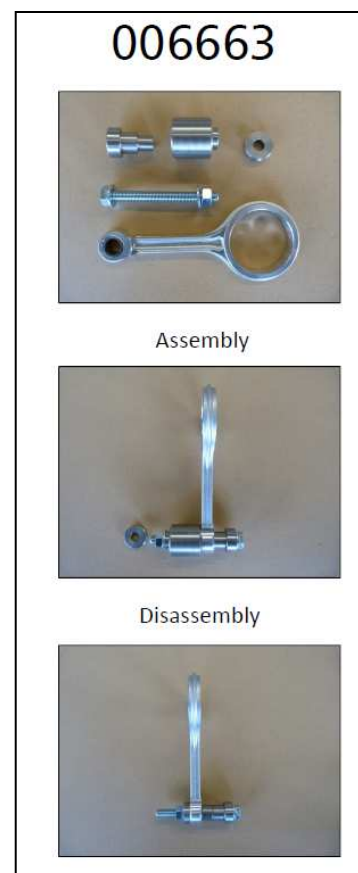

Fig. 3 - L&W special tool for 2nd stage 006663

## MAINTENANCE AND SERVICE

### Safety valves

Every pressure stage is equipped with a separate over pressure safety valve. Safety Valves avoid a non permissible high pressure at the specific pressure stages and limit maximum operation pressure of the compressor.

#### Safety valves are adjusted to:

- 1st Stage: 8 bar
- 2nd Stage: 50 bar
- 3rd Stage: max. final pressure

The adjusted blow-off pressure [bar] of the safety valves is indicated on their housings.

All safety valves are factory sealed with special L&W safety seals to avoid manipulation of the limit value settings.

Safety valves with removed seals have to be immediately checked for the prescribed settings and replaced if necessary.

The safety valve of the final stage is furthermore equipped with a knurled screw to be activated once.

Turning the knurled screw clockwise could vent the valve completely and therefore the final filter housing.

During normal operation conditions, the knurled screw has to be turned anti-clockwise up to the upper stop. An integrated circlip avoids complete unscrewing.

If a safety valve blows off, it indicates problems with either inlet or outlet valve of the following stage.



#### Note

Replace defective safety valves immediately!

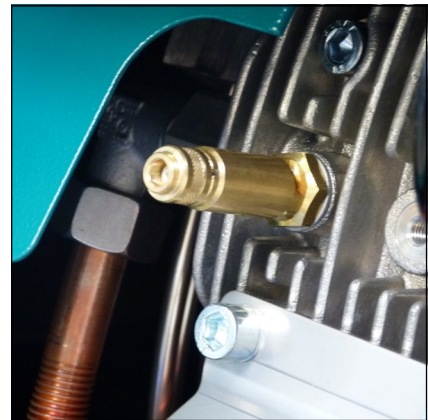

Safety valve 1st stage



Safety valve 2nd stage



Safety valve 3rd stage

A

### Pressure maintaining / non return valve



#### Note

If the adjusted opening pressure of the pressure maintaining valve is higher than the final pressure of the compressor, the final pressure safety valve blows off before pressure maintaining valve opens (final pressure = 0 bar). When valve settings are not clear (e.g. after disassembly / repair), start the adjustment with a low basic setting (turn adjusting screw approx. 3 times in).

A pressure maintaining / non return valve is installed after the filter housing. It maintains a pressure of at least 150 bar inside the filter housing - this optimises filter efficiency.

#### Pressure maintaining valve

The pressure maintaining valve drains a large part of the water content of the compressed air mechanically by ensuring the minimum outlet pressure. This guarantees optimal drying and purification of the breathing air.

After starting the compressor, the pressure inside the final filter housing constantly increases. The pressure maintaining valve prevents the compressed air from blowing off (final pressure gauge = 0 bar).

When the adjusted opening pressure is reached (150 and 180 bar), the purified compressed air flows via pressure maintaining and non return valve to the filling valve.

The value of the opening pressure of the pressure maintaining valve can be read at the final pressure gauge. When opening pressure is reached, the pressure gauge value increases within a few seconds.



Pressure maintaining/non-return valve

## MAINTENANCE AND SERVICE

### Safety valve test



#### Note

Do not fill any tank during test phase!

#### Safety valve test as follows:

- Disconnect compressor from the electrical power supply and protect against unexpected restart.
- Remove the cover of the switch box.
- Switch on the "Test Safety Valve" switch (pressure switch will be deactivated!).
- Mount the cover of the switch box.
- Connect the compressor to the electrical power supply.
- Close filling valves.
- Start the compressor.
- Watch the final pressure gauge. The safety valve should open when reaching working pressure of the compressor. If not, switch off the unit and take out of service until the safety valve has been replaced.
- Switch off the compressor (compressor vented).
- Disconnect the compressor from the electrical power supply and protect against unexpected restart.
- Remove the cover of the switch box.
- Switch off the "Test Safety Valve" switch (pressure switch will be activated!).
- Mount the cover of the switch box.
- Connect the compressor to the electrical power supply.

The safety valve test is now completed.

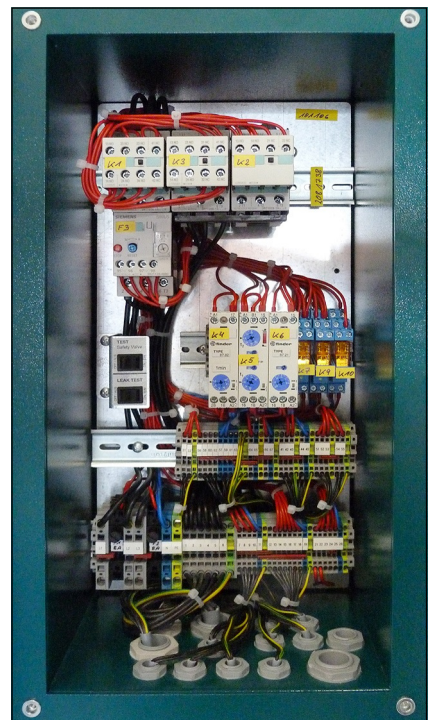

Switch box

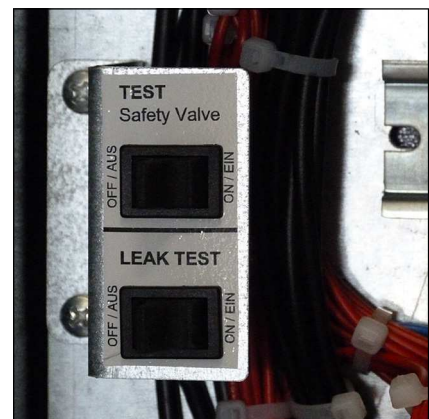

Safety valve test switch (up)



## MAINTENANCE AND SERVICE

### Leak test



#### Note

Do not fill any tank during test phase!

#### Leak test as follows:

- Disconnect the compressor from the electrical power supply and protect against unexpected restart.
- Remove the cover of the switch box.
- Switch on the leak test switch (solenoid valves will be deactivated!).
- Mount the cover of the switch box.
- Connect the compressor to the electrical power supply.
- Close filling valves.
- Start the compressor.
- Switch off the compressor at a pressure of approx. 150 bar.
- Verify the compressor for release noises. (A slight hiss of the air inlet filter nozzle can be ignored). If release noises occur, localise blow off position(s).
- Switch off the compressor.
- Disconnect the compressor from the electrical power supply and protect against unexpected restart.
- Remove the cover of the switch box.
- Switch off the leak test switch (solenoids will be activated!).
- Mount the cover of the switch box.
- Connect the compressor to the electrical power supply (compressor vented).

The leak test is now completed.



Switch box

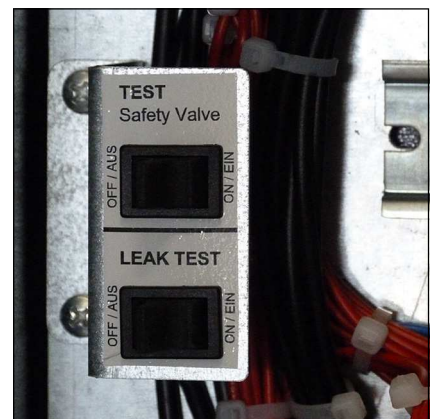

Leak test switch (lower)

## MAINTENANCE AND SERVICE

---

### Test of pressure equipment

According to the German Industrial Safety Ordinance 2015, pressure equipment is subject to regular inspection.

Subject: pressure equipment with a product permissible operating pressure [bar] x content volume [litres] from 200 up to 1000.

#### Example: Filter housing 1.7 l

Maximum operating pressure: 350 bar

Content volume: 1.7 litres

$350 \text{ bar} \times 1.7 \text{ litres} = 595$

595 is smaller than 1000 -> result: Test is applicable!!

#### Example: Filter housing 2.3 l

Maximum operating pressure: 350 bar

Content volume: 2.3 litres

$350 \text{ bar} \times 2.3 \text{ litres} = 805$

805 is smaller than 1000 -> result: Test is applicable!!

### Pressure equipment from 200 up to 1000 have to be tested as follows:

#### 1. Examination after 5 years by a qualified person or authorized organisations:

Visual inspection, inside and outside.

#### 2 Examination after 10 years by a qualified person or authorized organisations:

Visual inspection, inside and outside.

In addition, a water pressure test is carried out at 1.5 times of the permissible vessel operating pressure.



A

# MAINTENANCE RECORDS



# MAINTENANCE RECORDS

## Introduction form for the Operator

A

No.	Surname, Name	Date	Place	Signature	Instructor

By adding themselves to this list, the person that signs it confirms having been given a yearly introduction/instruction about the function and operation of the compressor unit. Furthermore, they have be informed about the relevant safety rules and regualtions (TRG, DGRL, BetrSichV, GSG, GSGV).







## MAINTENANCE RECORDS

---

### Cartridge change

Date	Operating hours	Difference	Name

A



## MAINTENANCE RECORDS

---

### Maintenance work

Description	Date, signature

A



## STORAGE

---

### Conservation / storage of the compressor

If the compressor is not to be used for an extended period of time, we recommend the following conservation work to be carried out before the storage:

- Run the compressor at 200 bar for approx. ten minutes
- Drain warm oil and replace by new oil.
- Open filling valves and run the compressor for a few minutes.
- Stop the compressor and open the drain valves.
- Close filling valves.
- Open the final filter housing and lubricate the O-Ring with a food grade grease or silicone grease.
- Store the compressor in a cool dry place free from dust and contamination. A cover is recommended as long as condensation can be avoided.

### De-conservation, commissioning

After the compressor has been stored, the following steps are to be taken:

- Replace the final purification filter.
- Check oil level, replace oil if necessary. Fuel Driven Units only: Fill up fuel tank to top level to avoid corrosion.
- Inspect the condition of the v-belts, replace if necessary
- Inspect the filling hoses visually for signs of deterioration, replace as necessary.
- Fix filling valves by e.g. cable strips to avoid whipping around wildly. Open filling valves.
- Open the filling valves and run the compressor for approx 10 minutes with the filling valves open.
- Close the filing valves and allow the compressor to build up to working pressure.
- Check the correct safety valve setting and/or pressure switch setting (option).
- Check all connections and pipe work for leaks, retighten if necessary.

Once the above steps are completed to satisfaction, the unit is ready to use.

## STORAGE

---

### Transportation instructions

- Parts which need to be dismantled for transport purposes must be carefully replaced and secured before taking into operation.
- The transport may only be carried out by trained personnel.
- For transportation, only use lifting devices and equipment with sufficient lifting power.
- Do not stand or work under suspended loads.
- Also separate from minor relocation machinery / system of any external energy supply. Before recommissioning, reconnect the machine to the mains according to regulations.
- When recommissioning, proceed according to the operating instructions..

### Disposal

The product must be disposed in accordance with national waste disposal regulations and by an appropriate waste disposal company.

### Electric and electronic components

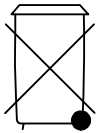

EU-wide regulations for the disposal of electric and electronic appliances which have been defined in the EU Directive 2002/96/EC and in national laws are effective from August 2005 and apply to this device.

Common household appliances can be disposed by using special collecting and recycling facilities. However, as this device has not been registered for household usage, it must not be disposed of through these means.

The device can be returned to L&W. Please do not hesitate to contact us if you have any further questions on this issue.

# Operating Instructions

## ECC - Electronic compressor control





## TABLE OF CONTENTS

---

### General Information

General Information .....	3
Description of Warning Symbols .....	3

### Description

Specifications / Options .....	4
Switchboard .....	5

### Operation and Function

Main Menu .....	6
Selection Menu (M100) .....	7
Display Menu (M200) .....	8
Inter-Stage Pressure Display.....	8
Display II (M270) .....	9
Settings Menu (M300).....	10
Set Stop Pressure - automatic mode (M320).....	11
Set Restart Pressure - automatic mode (M330).....	11
Set Stop Pressure - semi-automatic mode (M340) .....	11
Test Menu (M400) .....	12
Test Solenoids (M420) .....	12
Test safety valve (M430) .....	13
Test stop without venting (M440) .....	13
Statistics Menu (M500).....	14
Maintenance Menu (M600) .....	15
Confirm Maintenance (M680).....	16
Operation Mode (M700).....	17
Language Menu (M750) .....	17
Adjusting Display Backlight.....	18
Software Update .....	18
Spare part lists.....	19
Manufacturer in terms of 97/23/EC.....	20

B



## GENERAL INFORMATION

---

### General Information

We strongly recommend reading this manual thoroughly prior to operation and follow all the safety precautions precisely. Damage resulting from any deviation from these instructions is excluded from warranty and liability for this product. Carry out other commissioning steps only if you have fully understood the following contents.

Before commissioning and using the unit, carry out all the essential preliminary work and measures concerning legal regulations and safety. These are described on the following pages of this operation manual.

**B**

### Description of marks and warning signs

The following warning signs are used in this document to identify the corresponding warning notes which require particular attention by the user. The warning signs are defined as follows:



#### Caution

Indicates an imminently hazardous situation which, if not avoided, could result in serious injury, physical injury or death.



#### Warning

Indicates a potentially hazardous situation which, if not avoided, could result in physical injury or damage to the product or environment.



#### Note

Indicates additional information on how to use the unit.



## DESCRIPTION

---

### Specifications and Options

All L&W compressors can be optionally equipped with the all-electrical computer supported control system "ECC". It is easy to operate and allows multiple and individual settings.

#### Specifications

- LCD-Display with key pad
- Automatic & semi-automatic operation mode
- Automatic dump system
- Integrated counter for operation hours
- Integrated counter for load cycles
- Maintenance intervals automatically displayed
- Required service part numbers automatically displayed
- Fully adjustable pressure ranges for start and stop
- Warning messages ("Housing Open" / "Emergency Switch")
- Check of end-pressure safety valve possible
- Auto switch-off when system is not running
- Extendable by additional modules (e.g. external filling panel)
- Easy to operate menu
- Door position switch (housing open message)
- Load-free or depressurised start cycles

#### Options

- Oil pressure control
- Oil temperature control
- Cylinder head temperature control
- Inter stage pressure monitoring
- PIN controlled access
- Master / slave option (if more than one ECC equipped compressors are combined)

## DESCRIPTION

### Switchboard



No.	Description
1	LCD Display
2	Key Pad
3	LED Display (Compressor OFF)
4	LED Display (Power)
5	LED Display (Compressor ON)



## OPERATION AND FUNCTION

---

### Main Menu

Immediately after the compressor has been connected to power, the ECC-display shows the following Main Menu::

Charging	0 min	Present filling time in minutes
Total	0,0 h	Total operation hours
Start : 1	Stop : 0	Key 1 to start compressor / Key 0 to stop compressor
Help: *	OFF	* Key leads to submenus Current operation state = Off
Final Press	<b>0</b> bar	Present filling pressure

**B**

### The following keys can now be used:

Key	Function / Description
1	Start - Starts the compressor
0	Stop - Stops the compressor
*	Leads to the submenus

After typing the \* key the following Selection Menu appears.



## OPERATION AND FUNCTION

---

### Selection Menu (M100)

After typing the \* key in the Main Menu the following Selection Menu appears.

Selection:		
2	Display	Key 2 leads to submenu "Display"
3	Settings	Key 3 leads to submenu "Settings"
4	Test	Key 4 leads to submenu "Test"
5	Statistics	Key 5 leads to submenu "Statistics"
6	Maintenance	Key 6 leads to submenu "Maintenance"
7	Operation Mode	Key 7 leads to submenu "Operation mode"
(M100)	Return : #	Key # leads back to "Main Menu"

(M100) tells that you are currently on menu page 100.



#### Note

At any time, the unit can be started with key 1 or shut down with key 0.  
Caution: Risk of accident during maintenance work!

B

## OPERATION AND FUNCTION

### Display Menu (M200)

Pushing key 2 in the Selection Menu leads to Submenu "Display".

Display I:	
2	Press. Stage 1
3	Press. Stage 2
4	Press. Stage 3
5	Cyl. Head Temp.
6	Oil Temp.
7	Display II
(M200)	Return : #

Key 2 shows current pressure of the 1st stage\*

Key 3 shows current pressure of the 2nd stage

Key 4 shows current pressure of the 3rd stage

Key 5 shows temperature of the final stage cylinder head

Key 6 shows the oil temperature

Key 7 shows Display II

Key # leads back to "Main Menu"

(M200) tells that you are currently on menu page 200.

By pushing key 2 (inter-stage pressure 1) the following Display appears.

### Inter-Stage Pressure Display

Pushing key 2 in the Display Menu leads to the Inter-Stage Pressure 1 Display Menu.

Charging	0 min
Total	0,0 h
Start: 1	Stop: 0
Help:*	OFF
Press.	0 bar
1 <sup>st</sup> Stage	0,0 bar

Use keys 3 to 6 in the Menu "Display I" to change between the displayed values.



#### Note

Pushing key 8 in the display menu "Display II" leads to the option "Pressure200/300" for compressors with 2 filling pressures. Displayed in field 3 of the display menu "Display I".



## OPERATION AND FUNCTION

---

### Display II (M270)

Pushing key 7 in the Selection Menu leads to Menu "Display II".

#### Display II:

Press.	Temp.
4: 0	C: 0
5: 0	D: 0
6: 0	E: 0
7: 0	F: 0
bar	°C
(M270)	Return : #

This display shows further customer specific pressure and temperature values.

Key # leads back to "Main Menu"

**B**

## OPERATION AND FUNCTION

---

### Settings Menu (M300)

Pushing key 3 in the Selection Menu leads to the Settings Menu.

<b>Settings:</b>	
<b>Automatic</b>	
2	Stop pressure
3	Restart Press.
<b>Semi-Automatic</b>	
4	Stop Pressure
9	Close
(M300)	Return : #

Key 2 leads to submenu „Set Stop Pressure“

Key 3 leads to submenu „Set Restart Pressure“

Key 4 leads to submenu „Set Stop Pressure“

Key 9 leads back to submenu "Selection"

Key # leads back to "Main Menu"

**B**

Use menu M700 to change between "Automatic" and "Semi-Automatic" mode.

Restart pressure can only be set in "Automatic Mode".

Prior to setting the pressure, start the safety valve test.



#### Attention during maintenance

During automatic mode, the compressor can automatically start by itself at any time, depending on the selected restart pressure (see "Set Restart Pressure" M330).





## OPERATION AND FUNCTION

---

### Set Stop Pressure - automatic mode (M320)

Only valid in automatic mode, see menu M700.

**Set**  
**Stop Pressure:**  
Actual: 330 bar  
7 New Value:  
>> XXX bar  
4 (050,, 333)  
8 Confirm  
(M320) Return : #

Current restart pressure  
Key 7 if restart pressure should be changed  
XXX indicates modified stop pressure  
Chooseable pressure range for restart pressure  
Key 8 confirms new restart pressure  
Key # leads back to "Main Menu"

**B**

### Set Restart Pressure - automatic mode (M330)

Only valid in automatic mode, see menu M700.

**Set**  
**Restart Pressure:**  
Actual: 180 bar  
7 New Value:  
>> XXX bar  
4 (030,, 310)  
8 Confirm  
(M330) Return : #

Current restart pressure  
Key 7 if restart pressure should be changed  
XXX indicates modified restart pressure  
Chooseable pressure range for restart pressure  
Key 8 confirms new restart pressure  
Key # leads back to "Main Menu"

### Set Stop Pressure - semi-automatic mode (M340)

Only valid in semi-automatic mode, see menu M700.

**Set**  
**Stop Pressure:**  
Actual: 180 bar  
7 New Value:  
>> XXX bar  
4 (030,, 310)  
8 Confirm  
(M340) Return : #

Current stop pressure  
Key 7 if stop pressure should be changed  
XXX indicates modified stop pressure  
Chooseable pressure range for stop pressure  
Key 8 confirms new restart pressure  
Key # leads back to "Main Menu"

## OPERATION AND FUNCTION

### Test Menu (M400)

Pushing key 4 in the Selection Menu leads to the Test Menu.

Test:	
2	Solenoids
3	Safety Valve
4	Test-Stop
9	Close
(M400)	Return : #

Key 2 leads to submenu "Test Solenoids"

Key 3 leads to submenu "Test Safety Valve"

Key 4 leads to submenu "Test Stop without Venting"

Key 9 leads back to submenu "Selection"

Key # leads back to "Main Menu"

**B**

### Test Solenoids (M420)

Pushing key 2 in the Selection Menu leads to Submenu "Test Solenoids".

Test Solenoids	
3	open
7	close
9	Close
(M420)	Return : #

Key 3 opens solenoids

Key 7 closes solenoids

Key 9 leads back to submenu „Test“

Key # leads back to "Main Menu"



#### Note

This menu can not be left unless solenoids have been closed by key 7.

## OPERATION AND FUNCTION

### Test safety valve (M430)

Pushing key 3 in the Test Menu leads to Submenu "Test Safety Valve".



#### Note

Prior to starting the Test, close all filling connections (also connected filling panels if necessary). During this test, the compressor passes the selected stop pressure (see Menu M320) to test the correct function of the final pressure safety valve. This would limit the maximum operating over pressure of the unit in case of malfunction.

B

**Test**

**Safety Valve**

Close Filling Valves!

5 Start	0 Stop
9 Close	
(M430) Return : #	

Key 5 to start test      Key 0 to stop test

Key 9 leads back to submenu „Test“

Key # leads back to "Main Menu"

### Test stop without venting (M440)

Pushing key 4 in the Test Menu leads to Menu "Test Stop without Venting".



#### Note

This test is only operable when the compressor has been started with key 1. This test mainly checks the leak tightness of pressure vessels, pressurised pipes, safety valves and the compressor block.

**Test**

**stop without venting:**

5 Stop	
6 Vent	
Pressure	0
	bar
9 Close	
(M440) Return : #	

Key 5 stops compressor during test run

Key 6 vents compressor after leak search has been finished

Shows current filling pressure

Key 9 leads back to submenu „Test“

Key # leads back to "Main Menu"



## OPERATION AND FUNCTION

---

### Statistics Menu (M500)

Pushing key 5 in the Selection Menu leads to Submenu "Statistics".

Statistics	
Operation Hours:	0,0 h
Start cycles:	00
Max Press	000 bar
9 Close	
(M500) Return : #	

Total operation hours of compressor unit

Total number of compressor starts

Maximum working pressure of unit (set by safety valve test)

Key 9 leads back to submenu „Selection“

Key # leads back to "Main Menu"

Push key 5 to get information on which ECC software version is currently installed on your system (M505), i.e.: By pushing key 2, the total load cycles of the filter housing are being indicated.

**B**

## OPERATION AND FUNCTION

---

### Maintenance Menu (M600)

Pushing key 6 in the Selection Menu leads to the "Maintenance Menu".

Hours remaining		
Oil change	14 h	Shows remaining hours of listed components (i.e. next oil change in 14 hours,...)
Sinter filt	989 h	
Silencer	4989 h	
Valves	5989 h	
Oil filter	1000 h	
8 Change done		Key 8 leads to submenu "Receipt Maintenance"
9 Close		Key 9 leads back to submenu „Selection“
(M600)      Return : #		Key # leads back to "Main Menu"

Remaining hours depend on the type. At the end of any remaining hours, the display indicates a warning message. Furthermore, the display informs about any possibly necessary spare parts with the corresponding L&W service part number.



#### Attention during maintenance

During automatic mode, the compressor can automatically start by itself at any time, depending on the selected restart pressure (see "Set Restart Pressure" M330).



## OPERATION AND FUNCTION

---

### Confirm Maintenance (M680)

Confirm Maintenance	
2	Oil change
3	Sinter filters
4	Silencer
5	Valves
6	Oil filter
(M680)	Return : #

Key 2 receipts oil change  
Key 3 receipts change of sinter filters  
Key 4 receipts change of silencer  
Key 5 receipts change of valves  
Key 6 receipts oil filter  
Key # leads back to "Main Menu"

**B**

Display confirms any reset of "Hours remaining" with the following message:

Confirm Maintenance	
Operation Hours Meter Set	
9	Close
(M680)	Return : #

Key 9 leads back to submenu "Hours remaining"  
Key # leads back to "Main Menu"

## OPERATION AND FUNCTION

---

### Operation Mode (M700)

Pushing key 7 in the Selection Menu leads to the menu "Operation Mode".

Activated modes are always displayed in bolt letters (above example: **Semi-Automatic**).

Further settings can be made in the Settings Menu (M300).

**B**

Betriebsart:	
2	Automatic
3	<b>Semi-Automatic</b>
4	bar /mpa
5	Sprache
9	Close
(M700)	Return : #

Key 2 activates automatic mode

Key 3 activates semi-automatic mode

Key 4 selects between bar and MPa (optional)

Key 5 leads to the "Language Menu"

Key 9 leads back to submenu „Selection“

Key # leads back to "Main Menu"

### Language Menu (M750)

Language Menu	
2	German
3	English
4	French
5	Spanish
6	Dutch
7	Language II
(M750)	Return : #

Key 7 optional language (e.g. Chinese)

Key # leads back to "Main Menu"

## OPERATION AND FUNCTION

---

### Adjusting Display Backlight

The brightness of the display can be adjusted with an adjusting screw on the back of the control.

### Software Update

Software updates can only be carried out by L&W. To carry out an update, the device has to be send to the L&W service.



Adjust brightness

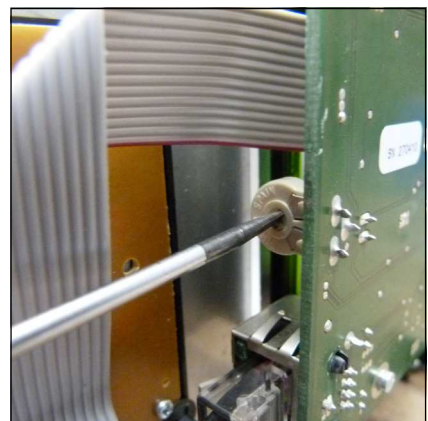

Adjust brightness



## SPARE PART LISTS

Best.-Nr. / Order No.	Benennung	Description
002141	1. Stufe Druckaufnehmer 0-10 bar	1st stage pressure sensor 0-10 bar
002142	2. Stufe Druckaufnehmer 0-60 bar	2nd stage pressure sensor 0-60 bar
002143	Endstufe Druckaufnehmer 0-400 bar	Final stage pressure sensor 0-400 bar
006890	Druckaufnehmer 420 bar Version 0-600 bar	Pressure sensor 420 bar version 0-600 bar
004840	Öldruckaufnehmer 0-6 bar	Oil pressure sensor 0-6 bar
006912	Öltemperatursensor	Oil temperature sensor
003501	Zylinderkopf - Temperatursensor	Cylinderhead temperature sensor

**B**



002141 / 002142 / 002143 / 004840  
Druckaufnehmer / Pressure sensor



006890 - Druckaufnehmer 420 bar /  
Pressure sensor 420 bar



006912 - Öltemperatursensor  
Oil temperature sensor



003501 - Zylinderkopf - Temperatursensor  
Cylinderhead temperature sensor



**LENHARDT & WAGNER GMBH**

---

**B**

**Manufacturer in terms of 97/23/EC**

The full name and address of the manufacturer is:

Lenhardt & Wagner GmbH

An der Tuchbleiche 39  
68623 Hüttenfeld / Germany

Phone: +49 (0) 62 56 - 85 88 0 - 0

Fax: +49 (0) 62 56 - 85 88 0 - 14

E-Mail: [service@lw-compressors.com](mailto:service@lw-compressors.com)

Internet: [www.lw-compressors.com](http://www.lw-compressors.com)





**ERSATZTEILLISTEN / SPARE PARTS LISTS  
DETAILANSICHTEN / DETAILED VIEWS**

C



## Inhaltsverzeichnis

---

Gehäuse - Housing .....	1
Schalttafel - Control Board.....	4
Fülldruckmanometer & Schlauch - Filling pressure Gauge & Hose.....	6
Kompressorblock - Compressor Block .....	8
Kurbelwelle - Crankshaft.....	12
Kolben 1. Stufe - Piston 1st Stage .....	14
Kolben 2. Stufe - Piston 2nd Stage.....	16
Kolben 3. Stufe - Piston 3rd Stage .....	18
Saug+Druckventil 1. Stufe - In+Outlet Valve 1st Stage.....	20
Saug+Druckventil 2. Stufe - In+Outlet Valve 2nd Stage .....	21
Saug+Druckventil 3. Stufe - In+Outlet Valve 3rd Stage .....	22
Öl+Wasserabscheider 1. Stufe - Oil+Water Separator 1st Stage.....	24
Öl+Wasserabscheider 2. Stufe - Oil+Water Separator 2nd Stage .....	26
Filter 0,8l - Filter 0.8ltr.....	28
Filtergehäuse 1,7 l - Filter Housing 1.7 ltr .....	30
Kondensat-Stopp-Ventil-Gehäuse - Condensate-Stop-Valve-Housing.....	32
Kondensat-Stopp-Ventil - Condensate-Stop-Valve .....	34
Kühler 1. Stufe - Cooler 1st Stage .....	36
Kühler 2. Stufe - Cooler 2nd Stage.....	38
Kühler 3. Stufe - Cooler 3rd Stage.....	40
Zusatzkühler - Additional cooler .....	42
Pneumatisches Kondensatventil - Pneumatic Condensate Valve .....	44
Druckhalteventil - Pressure Maintaining Valve.....	46
Druckschalter - Pressure Switch .....	48
Magnetventil - Solenoid Valve .....	50

---



## **Inhaltsverzeichnis**

---

Magnetventil mit Rückschlagventil - Solenoid Valve with non-return valve.pub .....	52
Sicherheitsventil - Safety Valve .....	54
Ansaugfilter - Air Intake Filter .....	56
Kondensat-Sammelbehälter - Condensate-Catch-Tank .....	58
Verteilerblock - Distributor Block .....	60
Ölpumpe - Oil Pump .....	62
Ölablassschlauch - Oil Drainage Tube .....	64
Motor .....	66
Lüfterrad - Cooling Fan .....	68

---



## ERSATZTEILLISTE / SPARE PART LIST

### Baugruppe: Gehäuse / Assembly: Housing

Best.-Nr. / Order No.	Benennung	Description
000498	U-Scheibe A6	Washer A6
000663	Einbaumanometer mit Befestigungsbügel	Press. Gauge c/w fixing strap
000948	Flachkopfschraube M6x16mm DIN6912 8.8 ZN	Pan Head Bolt M6x16mm DIN6912 8.8 ZN
001029	Zylinderschraube M6x20mm DIN912 8.8 ZN	Allen Bolt M6x20mm DIN912 8.8 ZN
001042	Zylinderschraube M8x30mm DIN912 8.8 ZN	Allen Screw M8x30mm DIN912 8.8 ZN
001047	Zylinderschraube M6x12mm DIN912 8.8 ZN	Allen Bolt M6x12mm DIN912 8.8 ZN
001105	6-kant Schraube M10x60mm DIN933 8.8 ZN	Hexagon Bolt M10x60mm DIN933 8.8 ZN
001108	6-kant Schraube M10x80mm DIN933 8.8 ZN	Hexagon Bolt M10x80mm DIN933 8.8 ZN
001156	Stopfmutter M6 DIN985 ZN	Lock Nut M6 DIN985 ZN
001163	Mutter M10 DIN934 ZN	Nut M10 DIN934 ZN
001178	U-Scheibe A6	Washer A6
001186	U-Scheibe A10	Washer A10
001194	Federscheibe (Klappdeckel E-Gehäuse)	Wave Spring Washer A12
001677	Griffschale PVC-Schwarz	Plastic Snatch, PVC, black
001683	Schlauchanschlussstück G1/4", Alu	Alloy Hose Connector G1/4"
002506	Einbaumanometer 0-250bar	Pressure Gauge 0-250bar
003215	Klemmleiste Frontgitter	Terminal strip front guard
003218	Buchsen Deckelbefestigung	Fixing kit for casing cover
005437	Standfuß, Höhenverstellbar	Foot, Height adjustable Ø80 mm
005842	Linsenflanschschraube mit Innensechskant	Lens Head Screw
006164	Befestigungsklammer Griffschale	Clip for Moulded Recess
006461	Halteblech Kondensatbehälter	Bracket Condensate Catch Tank
008192	Schutzgitter, hinten	Rear Grating - zinc plated
009111	Klappdeckel	Cover Lid
009112	Elektrodeckel	Electro Cover
009113	Wartungsdeckel	Maintenance Cover
009826	Kompressorgehäuse LW 450 E III	Housing LW LW 450 E III



## ERSATZTEILLISTE / SPARE PART LIST

---

### Baugruppe: Gehäuse / Assembly: Housing

Best.-Nr. / Order No.	Benennung	Description
009833	Frontgitter, vorne	Front Grating - zinc plated
009902	Steckschlüssel Personenschutzschalter	Key safety switch

C

# DETAILANSICHT / DETAILED VIEW

## Baugruppe: Gehäuse / Assembly: Housing

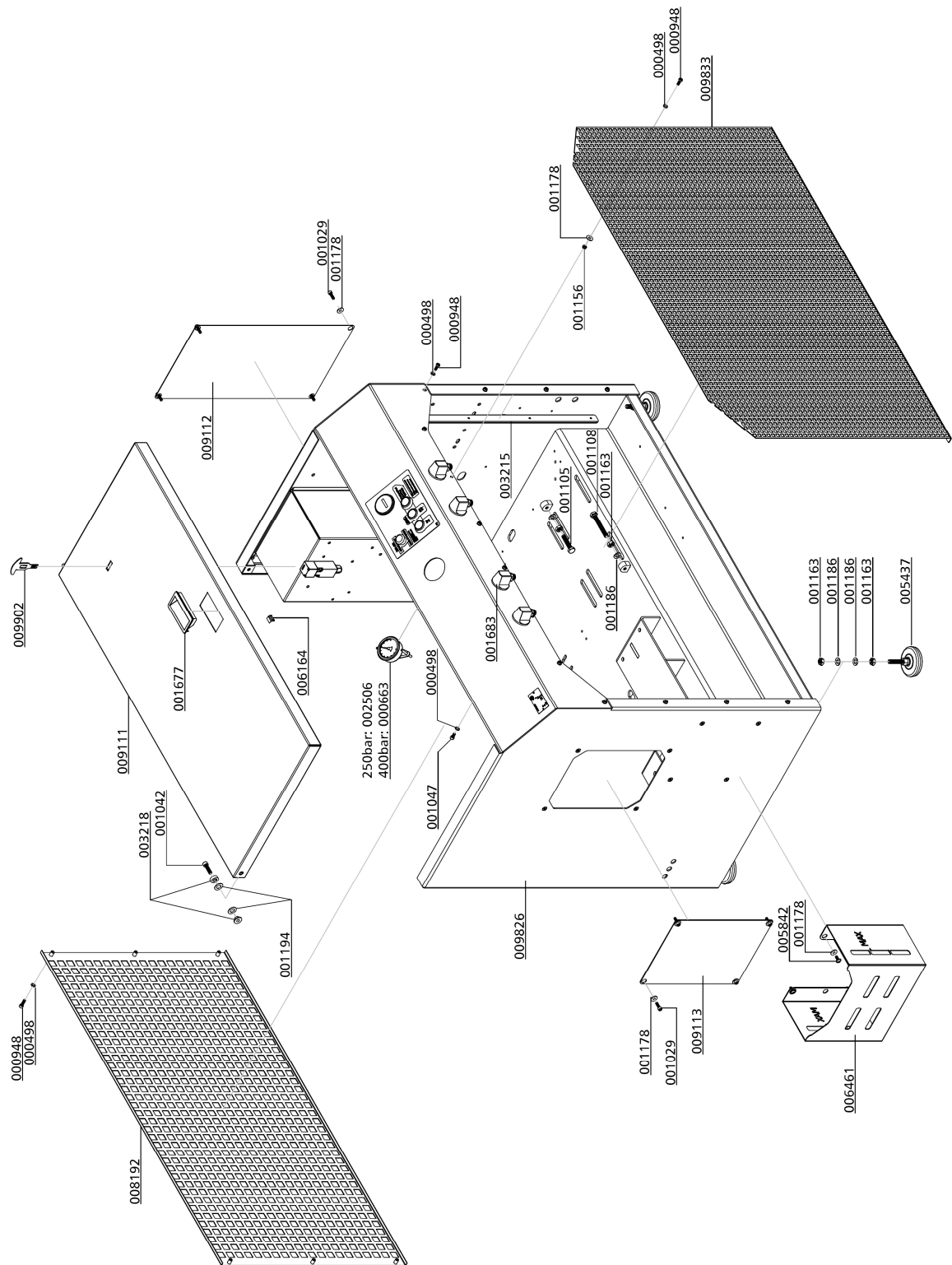

C





## ERSATZTEILLISTE / SPARE PART LIST

---

### Baugruppe: Schalttafel / Control Board

Best.-Nr. / Order No.	Benennung	Description
002089	Betriebsstunderzähler 230V	Hour Counter 230V
002502	Taster blau (komplett inkl. Halterung und Schließer)	Blue button (complete with bracket and closing contact)
002504	Taster grün (komplett inkl. Halterung und Schließer)	Green button (complete with bracket and closing contact)
003121	Not-Halt Schalter	Emergency switch
008153	Taster rot (komplett inkl. Halterung, Schließer und LED)	Red button (complete with bracket, closing contact and LED)

C

**DETAILANSICHT / DETAILED VIEW**

**Baugruppe: Schalttafel / Control Board**

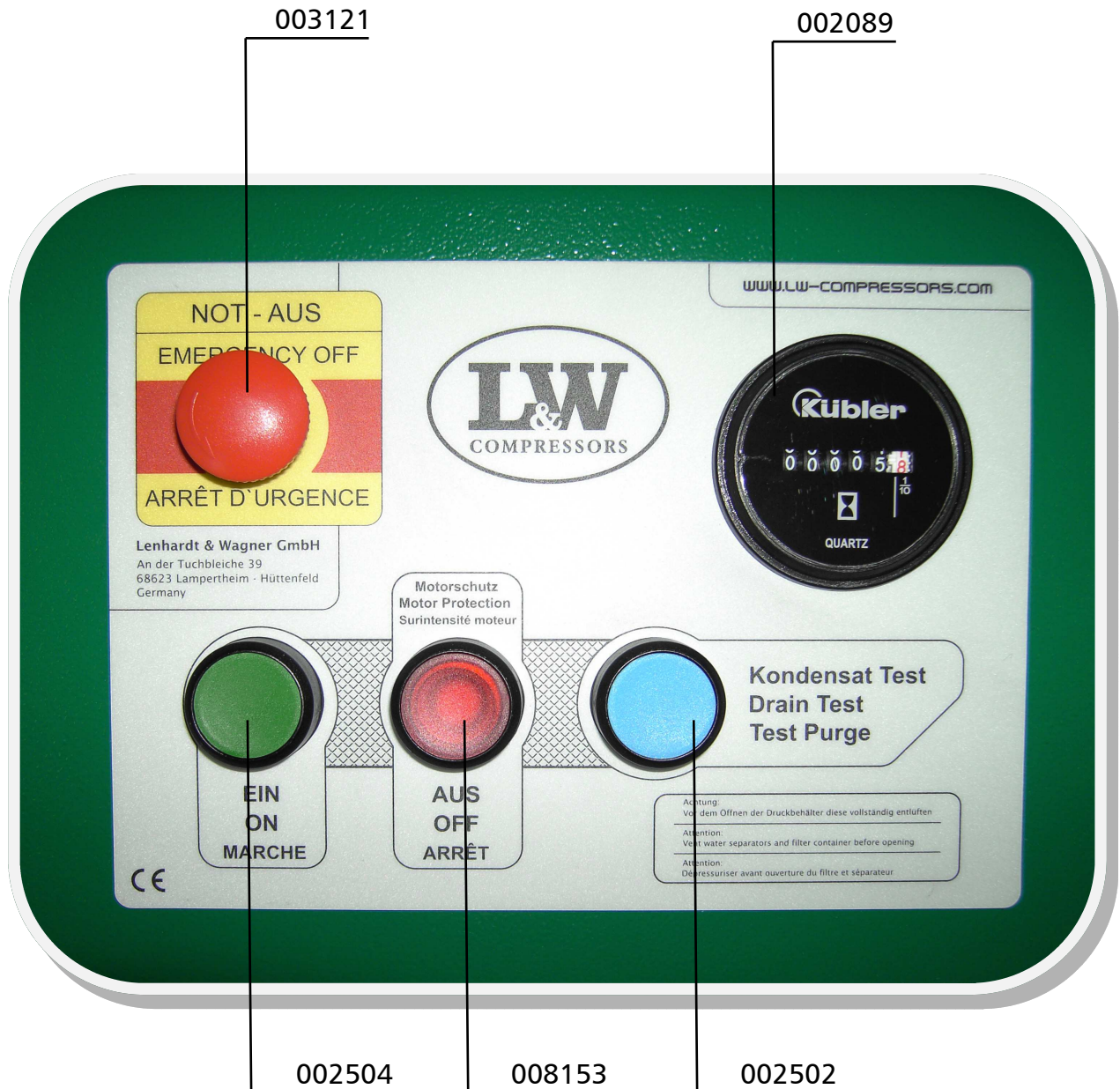

C



## ERSATZTEILLISTE / SPARE PART LIST

---

### Baugruppe: Fülldruckmanometer & Schlauch / Filling Pressure Gauge & Hose

Best.-Nr. / Order No.	Benennung	Description
000663	Manometer 0-400 bar	Pressure Gauge 0-400 bar
002506	Manometer 0-250 bar	Pressure Gauge 0-250 bar
004169	Hochdruckschlauch 1000mm	High Pressure Hose 1000mm

C

**DETAILANSICHT / DETAILED VIEW**

---

**Baugruppe: Fülldruckmanometer & Schlauch / Filling Pressure Gauge & Hose**

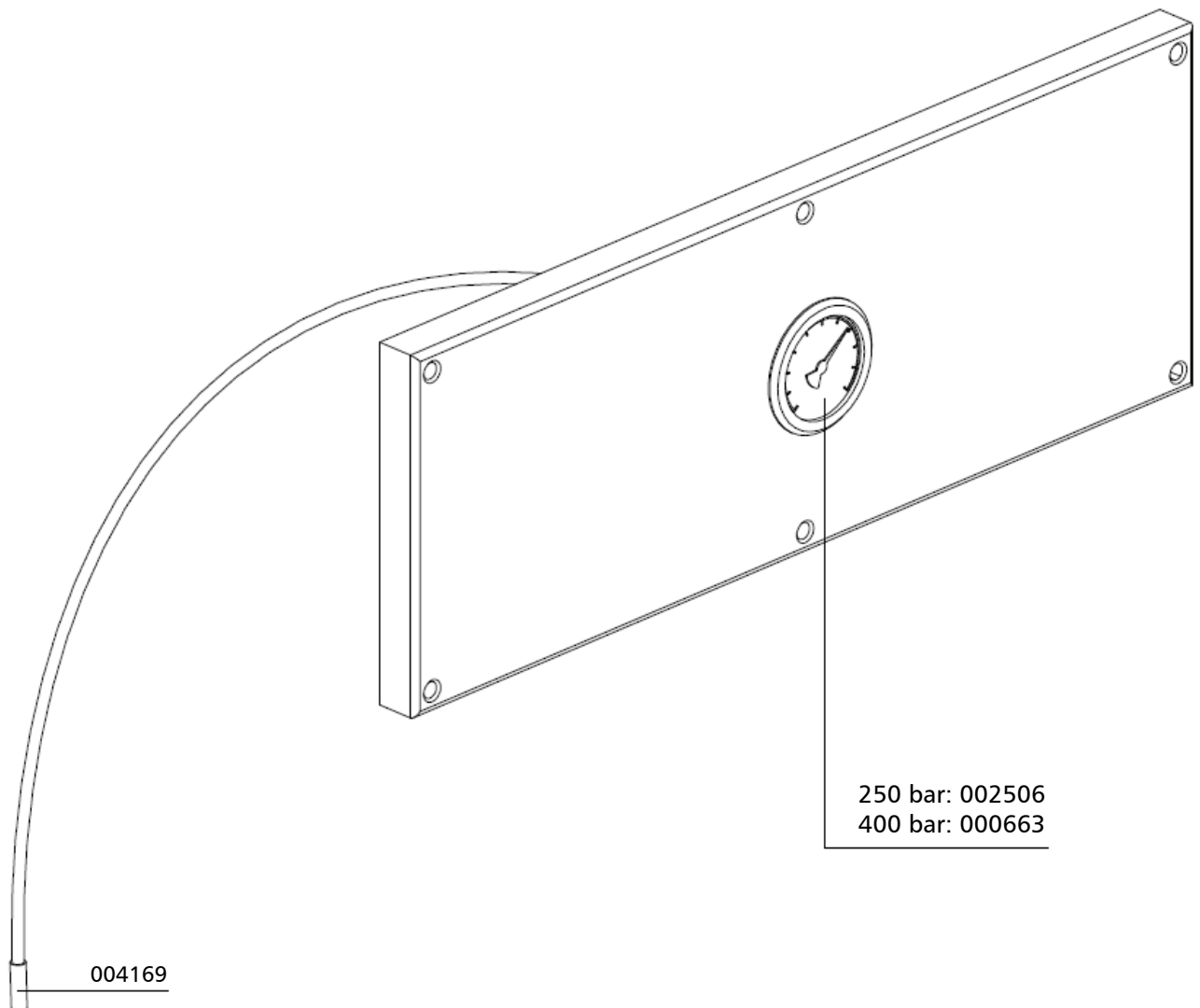

C



## ERSATZTEILLISTE / SPARE PART LIST

### Baugruppe: Kompressorblock / Assembly: Compressor Block

Best.-Nr. / Order No.	Benennung	Description
000180	Ölschlauchstutzen	Oil hose clip
000209	Öleinfüllstopfen	Oil Filler Plug
000220	Sicherheitsventil G3/8", 8bar	Safety valve G3/8", 8bar
000225	Sicherheitsventil G3/8", 50bar	Safety valve G3/8", 50bar
000253	Untere Ventildichtung 2.Stufe	Lower valve gasket 2nd stage
000254	Obere Ventildichtung 2.Stufe	Upper valve gasket 2nd stage
000257	Obere Ventildichtung 1.Stufe	Upper valve gasket 1 <sup>st</sup> stage
000258	Untere Ventildichtung 1.Stufe, Kupfer	Lower valve gasket 1 <sup>st</sup> stage, copper
000270	Ventilkopf 2.Stufe	Valve head 2nd stage
000274	Zylinder Ø42mm	Cylinder Ø42mm
000344	Führungszylinder	Guide Cylinder
000498	U-Scheibe DIN 125 A6	Washer DIN 125 A6
000710	Verschraubung GE06LRFCX	Connection GE06LRFCX
000738	Verschraubung GE 08 PLR 1/4"	Connection GE 08 PLR 1/4"
000761	Verschraubung WE 08 PLR CFX 1/4"	Elbow Connection WE 08 PLR CFX 1/4"
000817	Verschraubung GE15LR3/8CFX	Connection GE15LR3/8CFX
000818	Verschraubung GE15LRFCX	Connection GE15LRFCX
000837	Verschlussstopfen VSTI R1/8" ED	Plug VSTI R1/8" ED
000838	Verschlussstopfen VSTI R1/4" ED	Plug VSTI R1/4" ED
000839	Verschlussstopfen VSTI R3/8" ED	Plug VSTI R3/8" ED
000863	Verschraubung WE 18L R A3C	Elbow Connection WE 18L R A3C
000919	Reduzierung RI3/4X1/2CFX	Reducer RI3/4X1/2CFX
000952	Sechskantschraube M6x20mm, DIN933, 8.8	Hexagon Bolt M6x20mm, DIN933, 8.8
000961	Stiftschraube M8x25mm DIN939	Threaded Stud M8x25mm DIN939
001056	Zylinderschraube M8x60 DIN 912 8.8 ZN	Allen bolt M8x60 DIN 912 8.8 ZN
001058	Zylinderschraube M8x70 DIN 912 8.8 ZN	Allen bolt M8x70 DIN 912 8.8 ZN
001060	Zylinderschraube M8x80 DIN 912 8.8 ZN	Allen bolt M8x80 DIN 912 8.8 ZN
001088	Zylinderschraube M10x60 DIN 912 8.8 ZN	Allen bolt M10x60 DIN 912 8.8 ZN
001096	Zylinderschraube M10x120mm DIN912 8.8 ZN	Hexagon Bolt M10x120mm DIN912 8.8 ZN
001100	Sechskantschraube M10x25 DIN 933 8.8 ZN	Hexagon screw M10x25 DIN 933 8.8 ZN



## ERSATZTEILLISTE / SPARE PART LIST

### Baugruppe: Kompressorblock / Assembly: Compressor Block

Best.-Nr. / Order No.	Benennung	Description
001104	Sechskantschraube M10x50 DIN933 8.8 ZN	Hexagon screw M10x50 DIN933 8.8 ZN
001158	Mutter M8 DIN 934 ZN	Nut M8 DIN 934 ZN
001163	Mutter M10 DIN934 ZN	Nut M10 DIN934 ZN
001181	U-Scheibe A8 DIN 125 ZN	Washer A8 DIN 125 ZN
001186	U-Scheibe A10	Washer A10
001188	U-Scheibe A10 DIN 125 ZN	Washer A10 DIN 125 ZN
001190	Federring A10 DIN127 ZN	Spring Washer A10 DIN127 ZN
001274	O-Ring 50 x 2,5 NBR70, ab 05/2012	O-Ring 50 x 2,5 NBR70, since 05/2012
001346	Sicherungsring A40 DIN471	Circlip A40 DIN471
001766	O-Ring, Lagerdeckel 140 x 2 NBR70	O-Ring Bearing Cover 140 x 2 NBR70
001828	U-Scheibe A10,5 DIN6340 ZN	Washer A10,5 DIN6340 ZN
002111	Zylinder Æ95, 1.Stufe	Cylinder 1st stage
002358	Schnellkupplung gerade G1/8"- 6mm	Quick Release Coupling G1/8"- 6mm
002367	Ventilkopf 3.Stufe	Valve head 3rd stage
002478	Zylinder 3.Stufe, Æ18	Cylinder 3rd stage
002932	Distanzbolzen M6	Spacer M6
003189	Schlauschelle	Hose Clip
003190	Entlüftungsschlauch	Ventilation Hose
003191	Öleinfüllstopfen	Oil filter plug
003286	Ölschauglas	Oil gauge glass
003766	Aludichtring für G3/8"	Alloy Seal Ring for G3/8"
004749	PG Schlauchdurchführung, PVC	PVC hose c/W connection
006377	Alu-Distanzblock Kompressorblock	Alloy Spacer Compressor Block
006378	Alu-Distanzblock Kompressorblock	Alloy Spacer Compressor Block
008696	Sechskantschraube M10x30 DIN933 8.8 ZN	Hexagon Screw M10x30 DIN933 8.8 ZN
008849	Ölrohr	Oil Pipe
008850	Wellendichtringdeckel	Shaft Seal Cover
008873	Wellendichtring NBR RX 40 x 62 x 10 RST	Shaft Seal NBR RX 40 x 62 x 10 RST
008874	O-Ring 108x2 NBR 70	O-Ring 108x2 NBR 70
008877	O-Ring 81 x 2 NBR 70	O-Ring 81 x 2 NBR 70



## ERSATZTEILLISTE / SPARE PART LIST

### Baugruppe: Kompressorblock / Assembly: Compressor Block

Best.-Nr. / Order No.	Benennung	Description
009004	Kurbelwellenlager (Schwungradseite)	Main Roller Bearing (Position: Flywheel Side)
009005	Kurbelwellenlager (Ölpumpenseite)	Main Roller Bearing (Position: Oil Pump Side)
009053	Lagerdeckel	Main Bearing Flange
009132	Stiftschraube DIN 939, 8.8, M10x30, ZN	Threaded Stud DIN 939, 8.8, M10x30, ZN
009169	Kurbelgehäuse	Crankcase
009601	U-Scheibe DIN 1441 ST ZN 8	Washer DIN 1441 ST ZN 8
009649	Ventilkopf 1.Stufe	Valve head, 1st stage
009687	Halteblech-Ölschlauch LW 450 E / 450 EC	Bracket Oil Hose LW 450 E / 450 EC
009688	Halteblech-Ölschlauch LW300-530 ES	Bracket Oil Hose LW300-530 ES
009694	Öleinfüllschlauch Ø18mm, l=390mm, LW 450 E / 450 EC	Oil filler hose Ø18mm, l=390mm, LW 450 E / 450 EC
009695	Öleinfüllschlauch Ø18mm, l=325mm, LW 450 ES	Oil filler hose Ø18mm, l=325mm, LW 450 ES
009852	Gewindestange, M6x211mm	Threaded bar, M6x211mm
	BG Ansaugfilter	Ass: Intake Filter
	BG Kurbelwelle	Ass: Crankshaft
	BG: Ölablassschlauch	ASS: Oil Drainage Tube
	BG: Ölpumpe	ASS: Oil Pump
	BG: Kolben 1.Stufe	Ass: Piston 1 <sup>st</sup> stage
	BG: Kolben 2.Stufe	ASS: Piston 2nd stage
	BG: Kolben 3.Stufe	ASS: Piston 3rd stage
	BG: Ventil 1.Stufe	Ass: Valve 1 <sup>st</sup> stage
	BG: Ventil 2.Stufe	ASS: Valve 2nd stage
	BG: Ventil 3.Stufe	ASS: Valve 3rd stage

# DETAILANSICHT / DETAILED VIEW

## Baugruppe: Kompressorblock / Assembly: Compressor Block

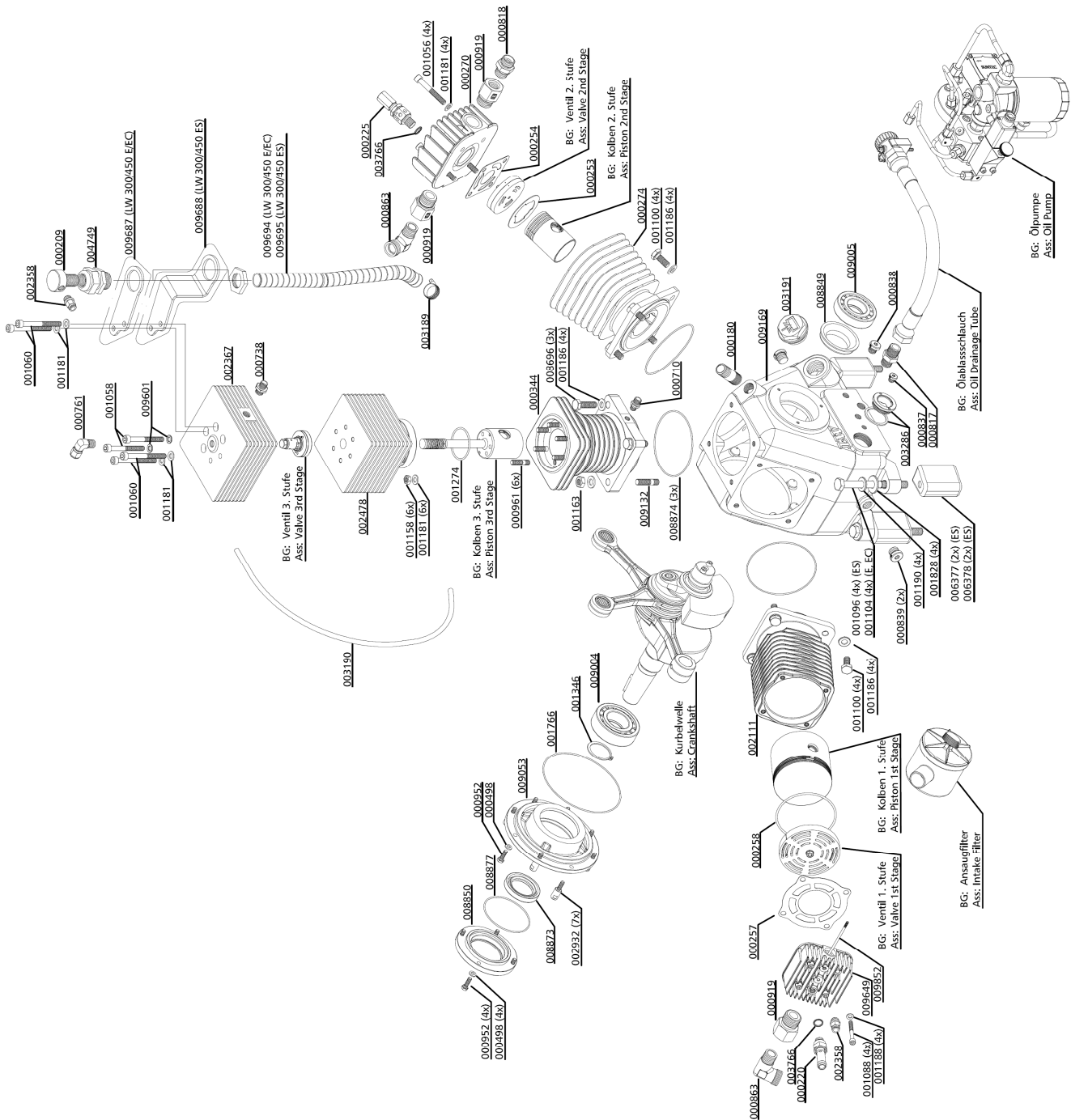



**Kurbelwelle / Crankshaft**

Best.-Nr. / Order No.	Benennung	Description
000245	Sicherungsring DIN 471 65 x 2,5	Circlip DIN 471 65 x 2,5
000247	Anlaufscheibe Kurbelwelle, mit Innenfase	Thrust Washer, chamfered version
000267	Pleuel LW 450 1.Stufe	Conrod 1 <sup>st</sup> Stage LW 450
000268	Pleuel LW 450 2.&3.Stufe	Conrod c/w Needle Bearing
001189	Schnorrzscheibe S10 N0110 ZN	Clamp Washer S10 N0110 ZN
001207	Passfeder, A8x7x35mm DIN6885	Woodruff Key
003281	Nadellager Pleuel Ø28xØ22x20mm	Needle bearing, con-rod Ø28xØ22x20 mm
003836	Nadellager Pleuel Ø22x Ø16x16mm	Needle Bearing, conrod Ø22xØ16x16mm
004809	Konischer Schraubenkopf M6x8mm	Drive bolt M6x8mm
007267	Zylinderschraube M10x45mm DIN912 10.9	Allen Bolt M10x45mm DIN912 10.9
008152	Pleuel inkl. Nadellager Ø28xØ22x20mm	Conrod c/w Needle Bearing Ø28xØ22x20mm
008848	Ölschleuderring	Oil Ring
008849	Ölrohr	Oil Pipe
008852	Anlaufscheibe Kurbelwelle	Thrust Washer
009004	Kurbelwellenlager (Schwungradseite)	Main Roller Bearing (Position: Flywheel Side)
009005	Kurbelwellenlager (Ölpumpenseite)	Main Roller Bearing (Position: Oil Pump Side)
009055	Kurbelwelle, komplett mit Gegengewicht und Schraube	Crankshaft c/w Counter Weight

**C**

**DETAILANSICHT / DETAILED VIEW**

**Kurbelwelle / Crankshaft**

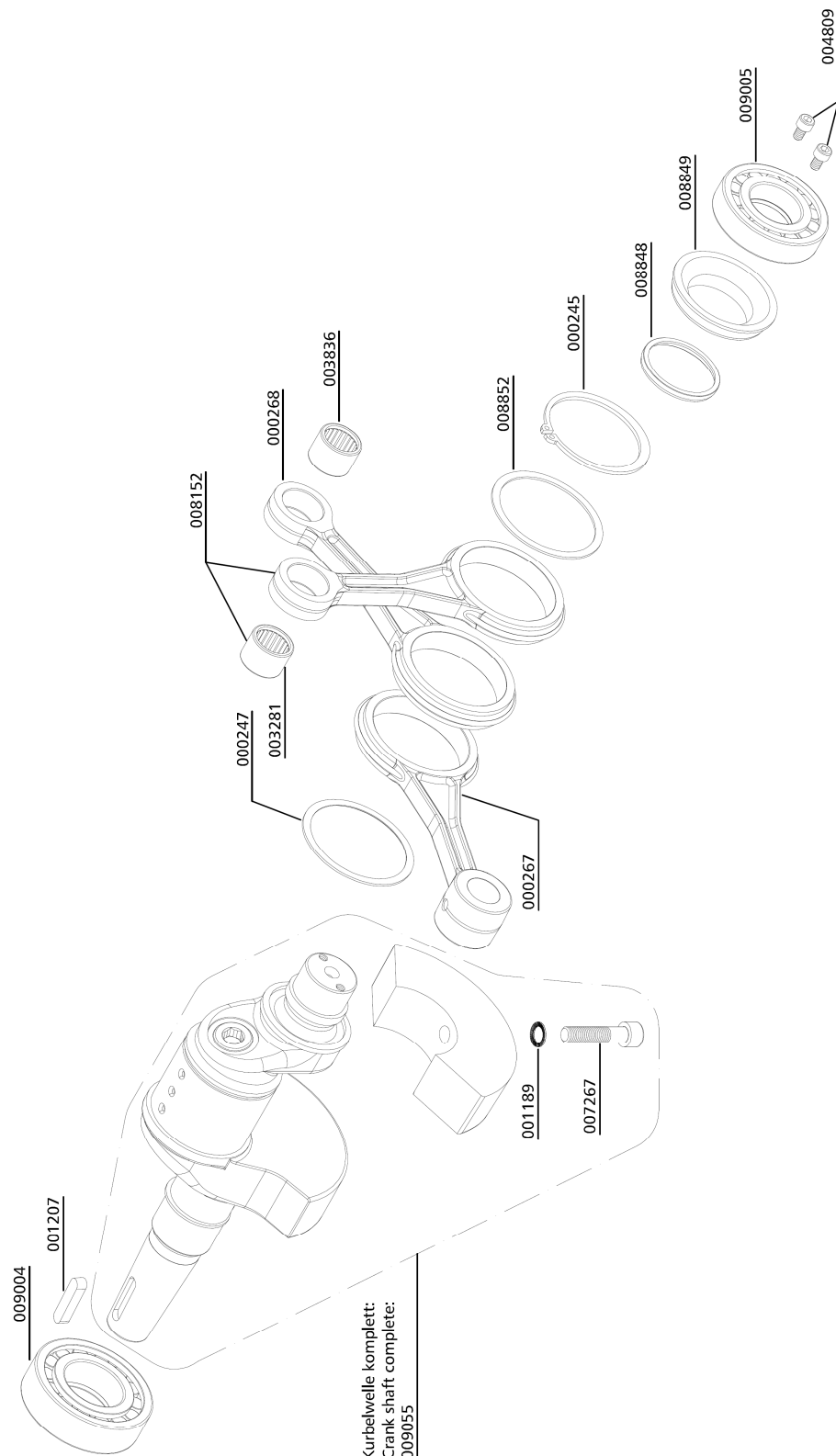



## ERSATZTEILLISTE / SPARE PART LIST

---

### Kolben 1. Stufe / Piston 1st Stage

Best.-Nr. / Order No.	Benennung	Description
000265	Kolbenringsatz 1.Stufe, Ø 95mm	Piston Ring Set 3pcs
000266	Kolben komplett 1.Stufe, Ø 95mm	Piston complete 1.Stage, Ø 95mm
001356	Sicherungsring, I22 DIN472	Circlip I22 DIN472
003900	Kolbenbolzen 1.Stufe, Ø 22x85mm	Piston Pin, 1.Stage, Ø 22x85mm

C

**DETAILANSICHT / DETAILED VIEW**

**Kolben 1. Stufe / Piston 1st Stage**

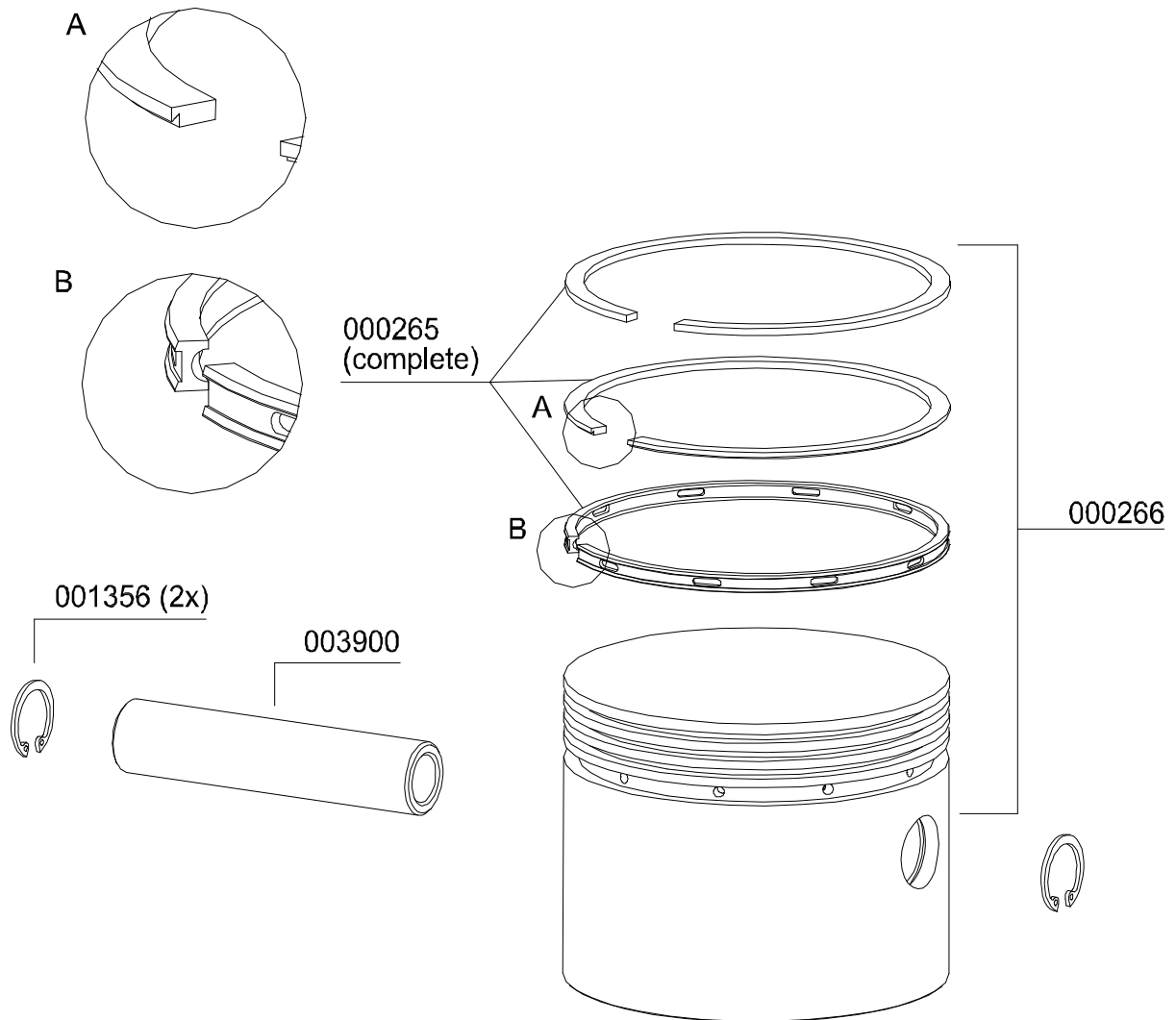

C



## ERSATZTEILLISTE / SPARE PART LIST

---

### Kolben 2. Stufe / Piston 2nd Stage

Best.-Nr. / Order No.	Benennung	Description
000263	Kolbenringsatz 2.Stufe, 4 Stk.,Ø42 mm	Piston Ring Set 2.Stage, 4pcs, Ø42mm
000264	Kolben kompl. mit Kolbenringen, 2.Stufe, Ø42x70mm	Piston c/w Rings, 2.Stage, Ø42x70mm
001002	Kolbenbolzen 2. + 3.Stufe, Æ16x33mm	Piston Pin 2.+3.Stage, Æ16x33mm
001353	Sicherungsring, I 16 DIN472	Circlip I 16

C

**DETAILANSICHT / DETAILED VIEW**

**Kolben 2. Stufe / Piston 2nd Stage**

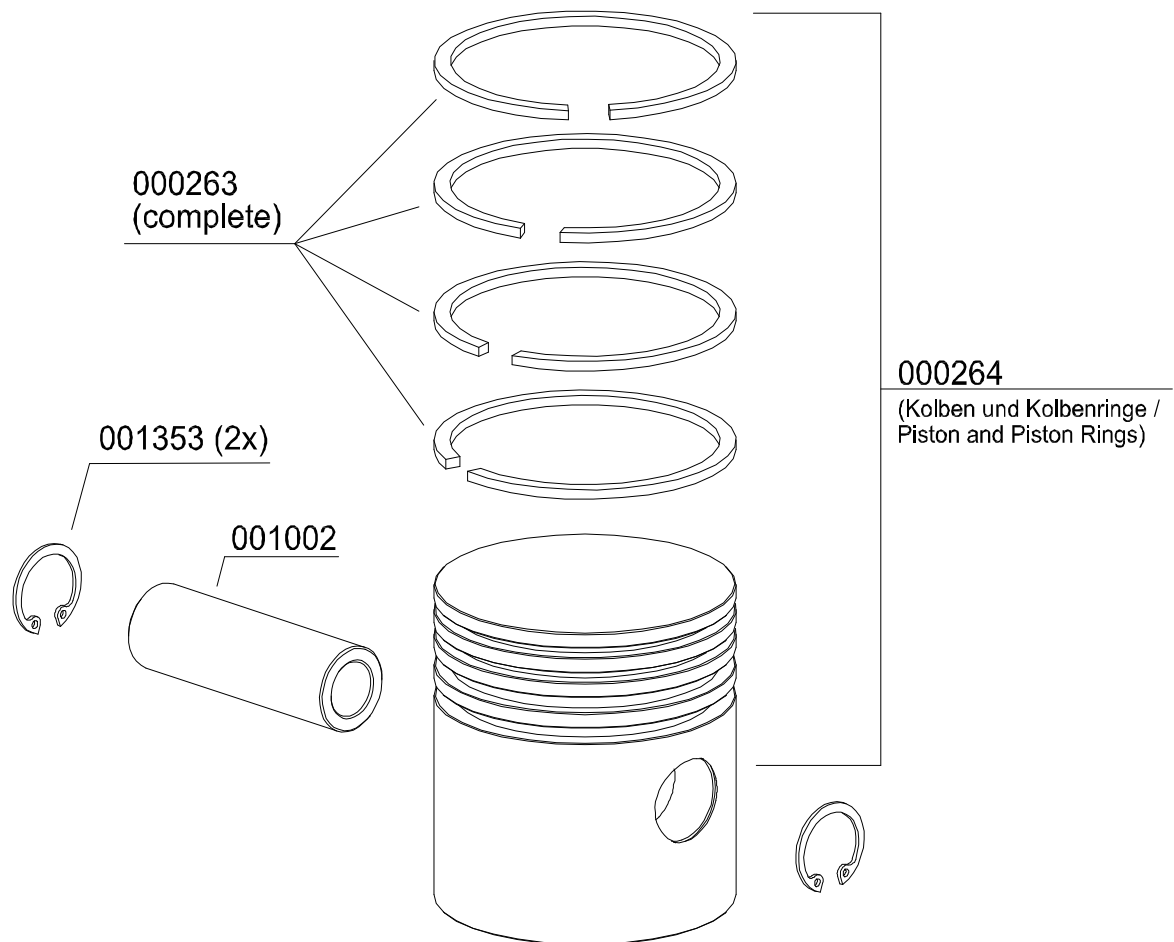



## ERSATZTEILLISTE / SPARE PART LIST

### Kolben 3. Stufe Ø18/50mm (ab 07.2016) / Piston 3rd Stage Ø18/50mm (since 07.2016)

Best.-Nr. / Order No.	Benennung	Description
000373	Kolbenbolzen Ø22 x 40 mm	Piston Pin Ø22 x 40 mm
001356	Sicherungsring, I 22 DIN472	Circlip I 16 DIN472
002324	Kolbenringsatz Ø18mm	Piston Rings Ø18mm
003285	Spezialwerkzeugsatz zur Kolbenring- u. Kolbenmontage	Special Tool Kit 3.Stage
006904	Kolben Piston Ø18mm/Ø50mm	Piston Ø18mm/Ø50mm
008731	Kolben Ø18mm/50mm mit Kolbenringen, Kolbenbolzen u. Seegerringen	Piston Ø18mm/50mm c/w piston rings, piston pin and circlips

C

**DETAILANSICHT / DETAILED VIEW**

**Kolben 3. Stufe Ø18/50mm (ab 07.2016) / Piston 3rd Stage Ø18/50mm (since 07.2016)**

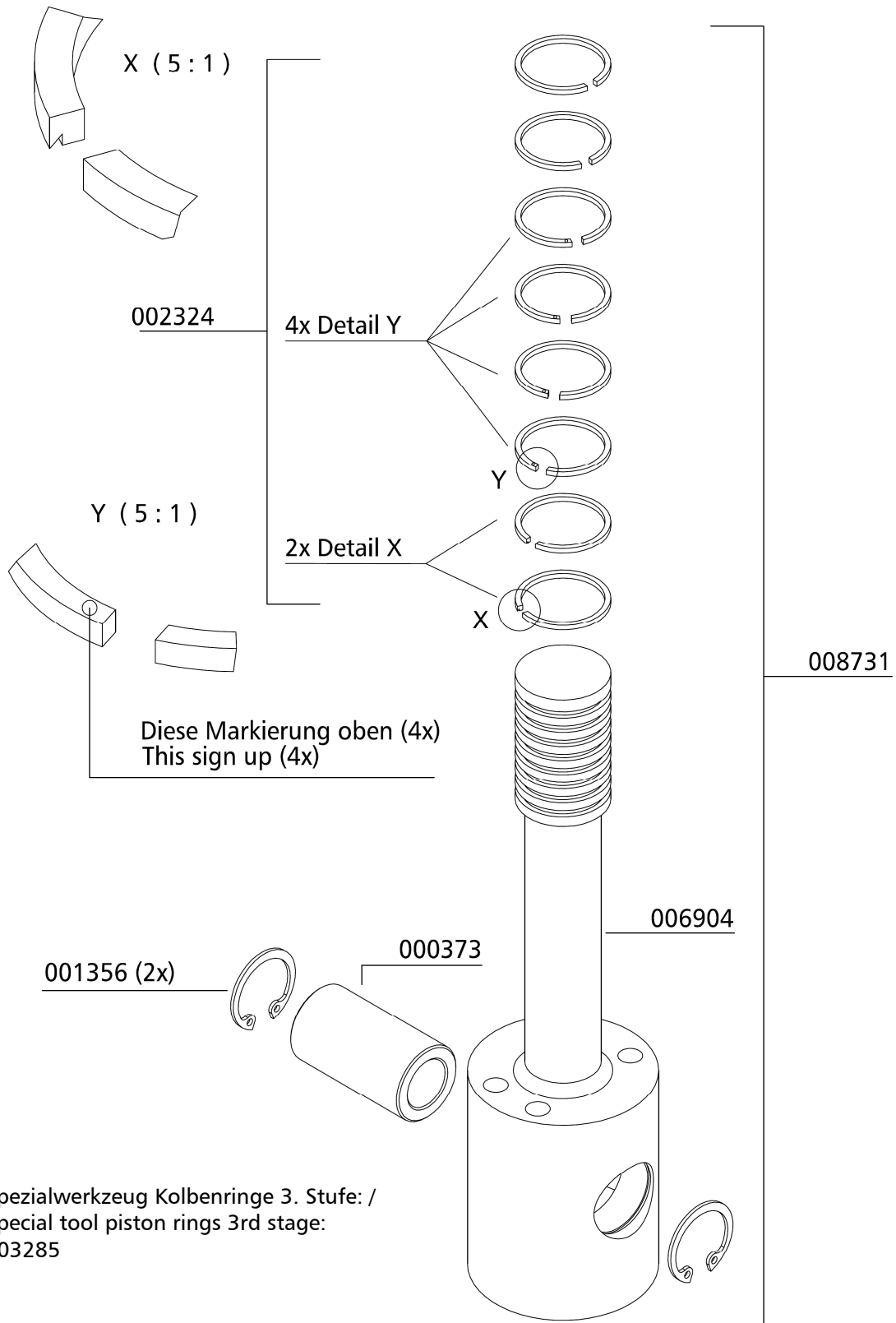

C



## ERSATZTEILLISTE / SPARE PART LIST

### Saug- und Druckventil 1. Stufe / In- and Outlet Valve 1st Stage

Best.-Nr. / Order No.	Benennung	Description
000259	Saug- Druckventil, 1. Stufe	In-&Outlet Valve, 1st Stage

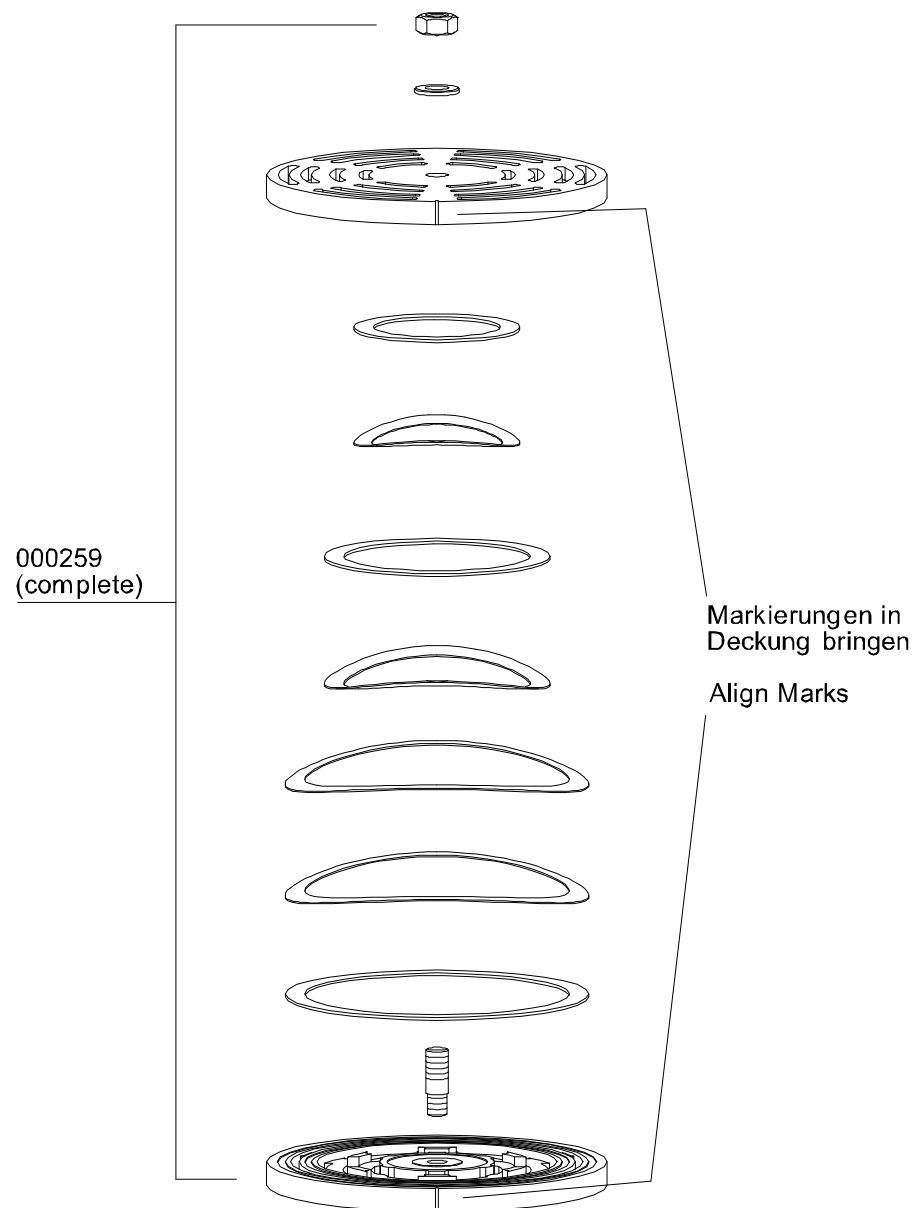

## ERSATZTEILLISTE / SPARE PART LIST

### Saug- und Druckventil 2. Stufe / In- and Outlet Valve 2nd Stage

Best.-Nr. / Order No.	Benennung	Description
000256	Saug- und Druckventil 2. Stufe	In- & Outlet Valve comp.2nd Stage

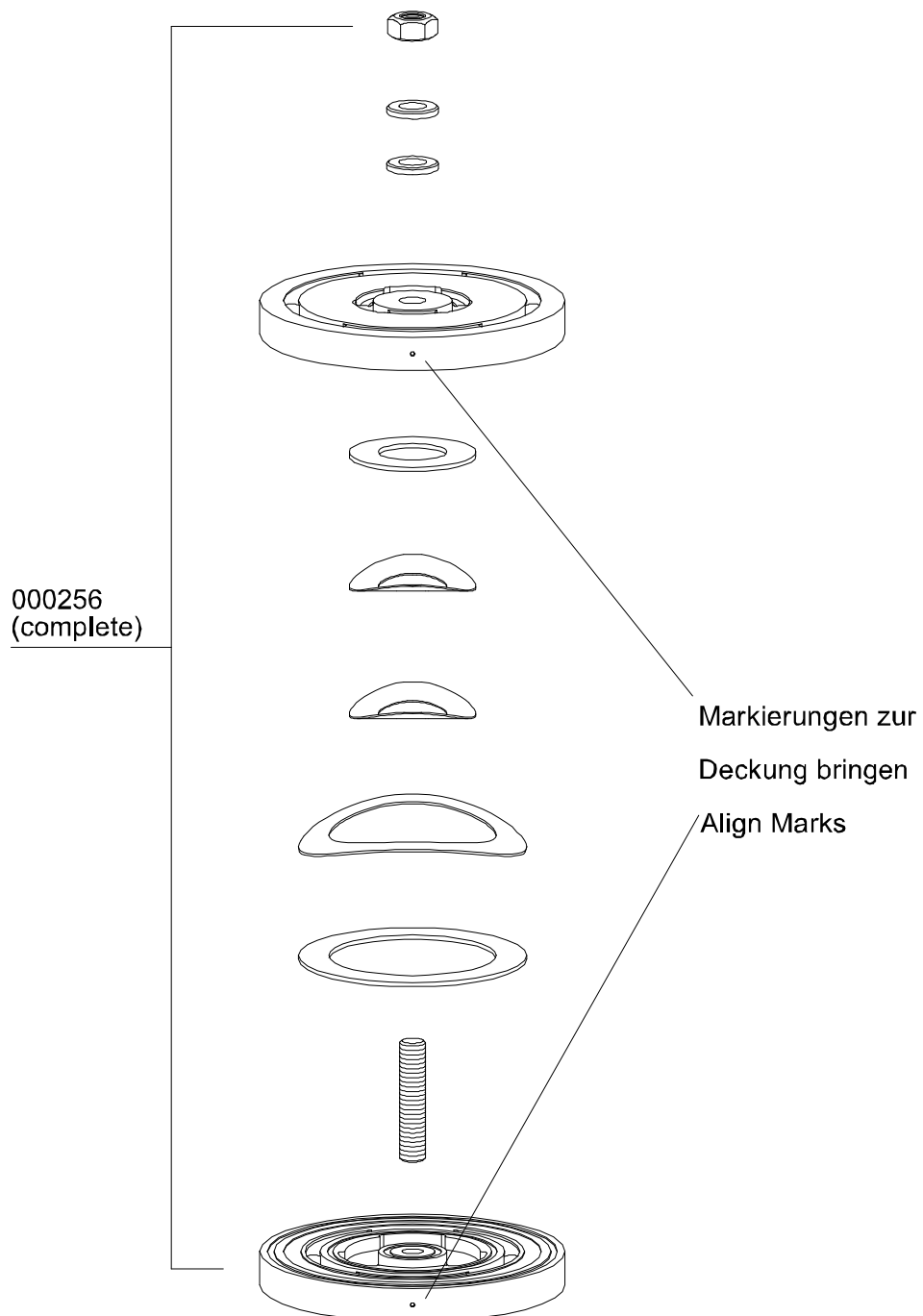

C



## ERSATZTEILLISTE / SPARE PART LIST

### Baugruppe: Ventil 3. Stufe / Assembly: Valve 3rd Stage

Best.-Nr. / Order No.	Benennung	Description
000525	Saug-Druckventil, ohne Dichtungen, 4 x Ø3,0mm, ab Kompressorblock-Nr. 859	In- & Outlet Valve, without gaskets, 4 x Ø3.0mm, from compressor block no. 859
000528	Ventildichtung, Saug-& Druckventil unten	Lower Valve Gasket
000540	Dichtring / Dichtung , Saug- u. Druckventil oben, Alu	Upper Alloy Seal Ring
000546	Saug-Druckventil, ohne Dichtungen, 4 x Ø3,0mm, bis Kompressorblock-Nr. 858	In- & Outlet Valve, without gaskets, 4 x Ø3.0mm, up to compressor block no. 858
010165	Saug-Druckventil kompl. mit Dichtungen, bis Kompressorblock-Nr. 858	In-& Outlet Valve c/w gaskets, up to compressor block no. 858
010337	Saug-Druckventil kompl. mit Dichtungen, ab Kompressorblock-Nr. 859	In-& Outlet Valve c/w gaskets, from compressor block no. 859

C

**ERSATZTEILLISTE / SPARE PART LIST**

**Baugruppe: Ventil 3. Stufe / Assembly: Valve 3rd Stage**

C

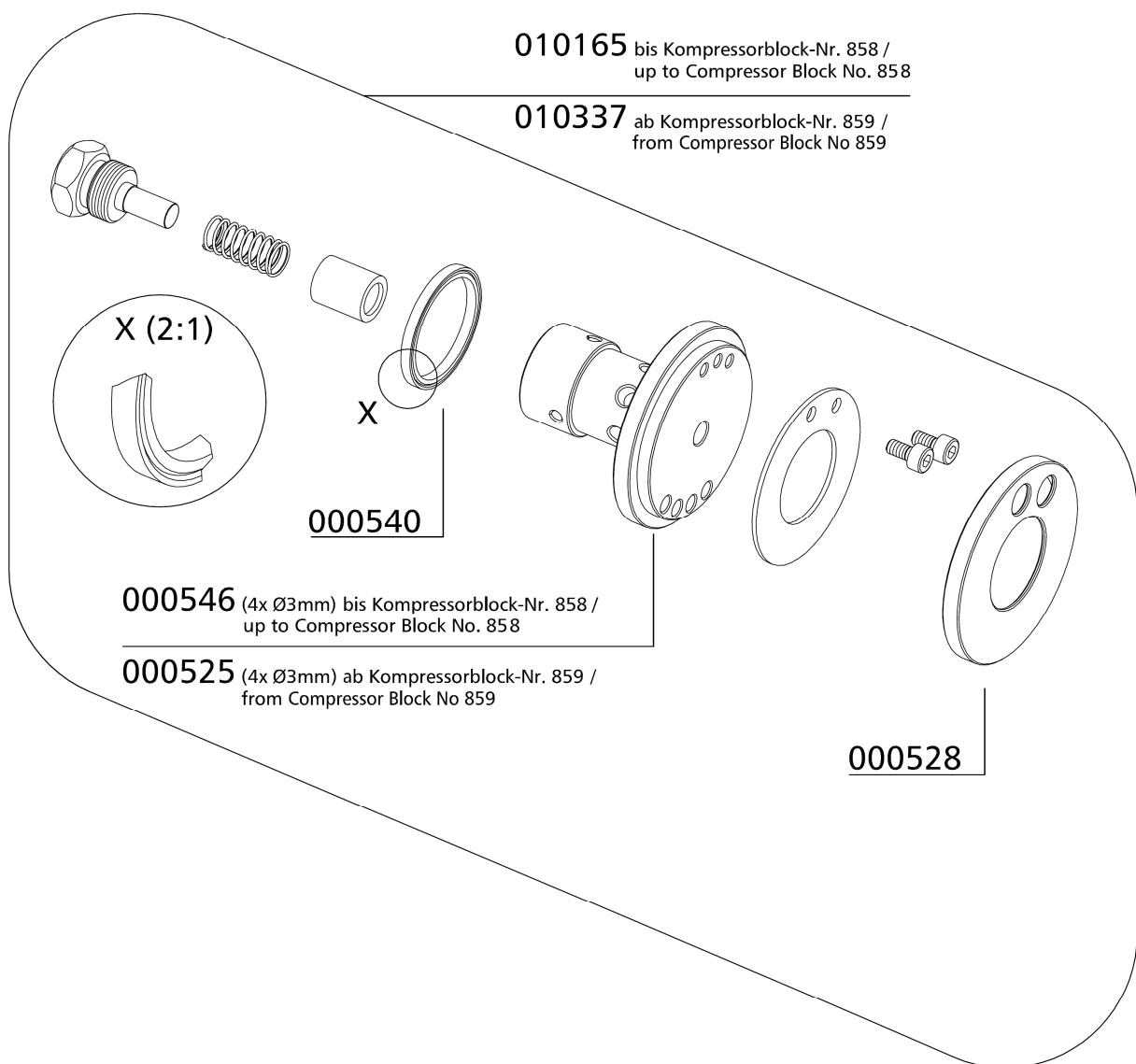



## ERSATZTEILLISTE / SPARE PART LIST

### Öl- / Wasserabscheider 1. Stufe / Oil- / Water Separator 1st Stage

Best.-Nr. / Order No.	Benennung	Description
000175	Deckel, Wasserabscheider	Cover Water Separator
000183	Wasserabweiser	Filter Protector
000184	Sinterfilter Wasserabscheider	Sintered Filter, Oil Filter
000185	Halteteller	Plate
000186	Drallscheibe	Twist Disk
000187	Stiftschraube	Threaded Stud
000820	Verschraubung WE 15L RX	Elbow Connection
000822	Mutter 15L	Nut 15L
000823	Schneidring PSR 15 LX	Olive Seal 15mm
000861	Schneidring PSR 18 LX	Olive Seal 18mm
000862	Mutter M18L	Nut 18L
000863	Verschraubung WE 18L	Elbow Connection
001133	Sechskant Schraube M12x30mm	Hexagon Screw M12x30mm DIN933 8.8
001191	U-Scheibe A12 DIN125 ZN	Washer A12 DIN125 ZN
001192	Federring A12 DIN 127 ZN	Spring Washer A12 DIN 127 ZN
001272	O-Ring 47x3 NBR70	O-Ring 47x3 NBR70
001294	O-Ring 68x3 NBR90	O-Ring 68x3
001431	Befestigungsring Wasserabscheider LW	Lock Ring Water Separator
002563	Wasserabscheider Oberteil	Water Separator Top
002914	Sinterfilter für Wasserabscheidersockel, M12x1,5mm	Sintered filt. water sep. base, M12x1,5mm
003347	Unterer Ring, Wasserabscheider	Base Ring, water separator
003348	Filterverschraubung für Wasserabscheider	Connec. for sintered filter
006421	Wasserabscheider-Behälter	Container Water Separ.
006845	Stopfmutter, Edelstahl, M6 DIN985	Lock Nut, s/s, M6 DIN985

**DETAILANSICHT / DETAILED VIEW**

**Öl- / Wasserabscheider 1. Stufe / Oil- / Water Separator 1st Stage**

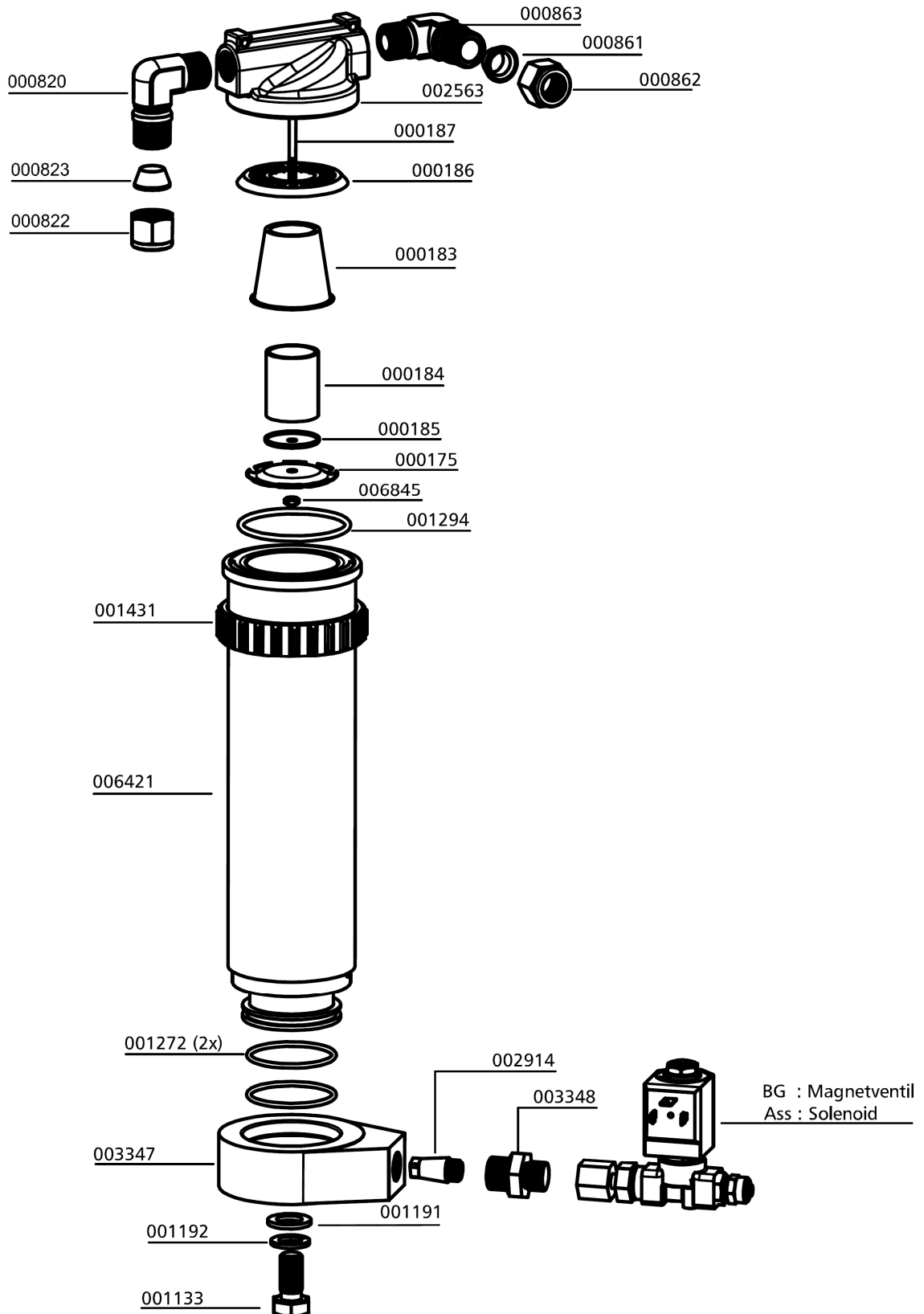

C



## ERSATZTEILLISTE / SPARE PART LIST

### Öl- / Wasserabscheider 2. Stufe / Oil- / Water Separator 2nd Stage

Best.-Nr. / Order No.	Benennung	Description
000172	Halteteller Wasserabscheider	Plastic Air Deflector
000173	Sinterfilter Wasserabscheider	Sintered Filter
000174	Drallscheibe, Wasserabscheider	Twist Disk
000176	Stiftschraube, Wasserabscheider	Treaded Stud
000177	Wasserabweiser, Wasserabscheider	Water Deflector, Plastic
000379	Wasserabscheider - Oberteil	Top ap Water Separator
000564	Wasserabscheider – Behälter 2.Stufe LW450	Container Water Separator
000761	Verschraubung WE08LRFCX	Elbow Connection WE08LRFCX
000765	Schneidring PSR 08 LX	Olive Seal PSR 08 LX
000766	Mutter L08	Nut L08
000837	Verschlussstopfen, VSTI R1/4"ED CFX	Plug
000839	Verschlussstopfen, VSTI R3/8"ED CFX	Plug
000863	Verschraubung	Elbow Connection
000924	Reduzierung 1/4"x1/8"	Reducer 1/4"x1/8"
001133	Sechskantschraube M12x30mm DIN933 8.8 ZN	Hexagon Screw M12x30mm DIN933 8.8 ZN
001191	U-Scheibe A12 DIN125 ZN	Washer A12 DIN125 ZN
001192	Federring A12 DIN 127 ZN	Spring Washer A12 DIN 127 ZN
001272	O-Ring Wasserabscheider 47x3 NBR70	O-Ring 47x3
002914	Sinterfilter für Wasserabscheidersockel, M12x1,5mm	Sintered filt. water sep. base, M12x1,5mm
003347	Unterer Ring, Wasserabscheider	Base Ring, water separator
006845	Stoppmutter, Edelstahl, M6 DIN985	Lock Nut, s/s, M6 DIN985
008827	Kondensat-Stopp-Ventil Einsatz	Condensate-Stop-Valve Assembly
009693	Filterverschraubung für Wasserabschei- der	Connec. for sintered filter

**DETAILANSICHT / DETAILED VIEW**

**Öl- / Wasserabscheider 2. Stufe / Oil- / Water Separator 2nd Stage**

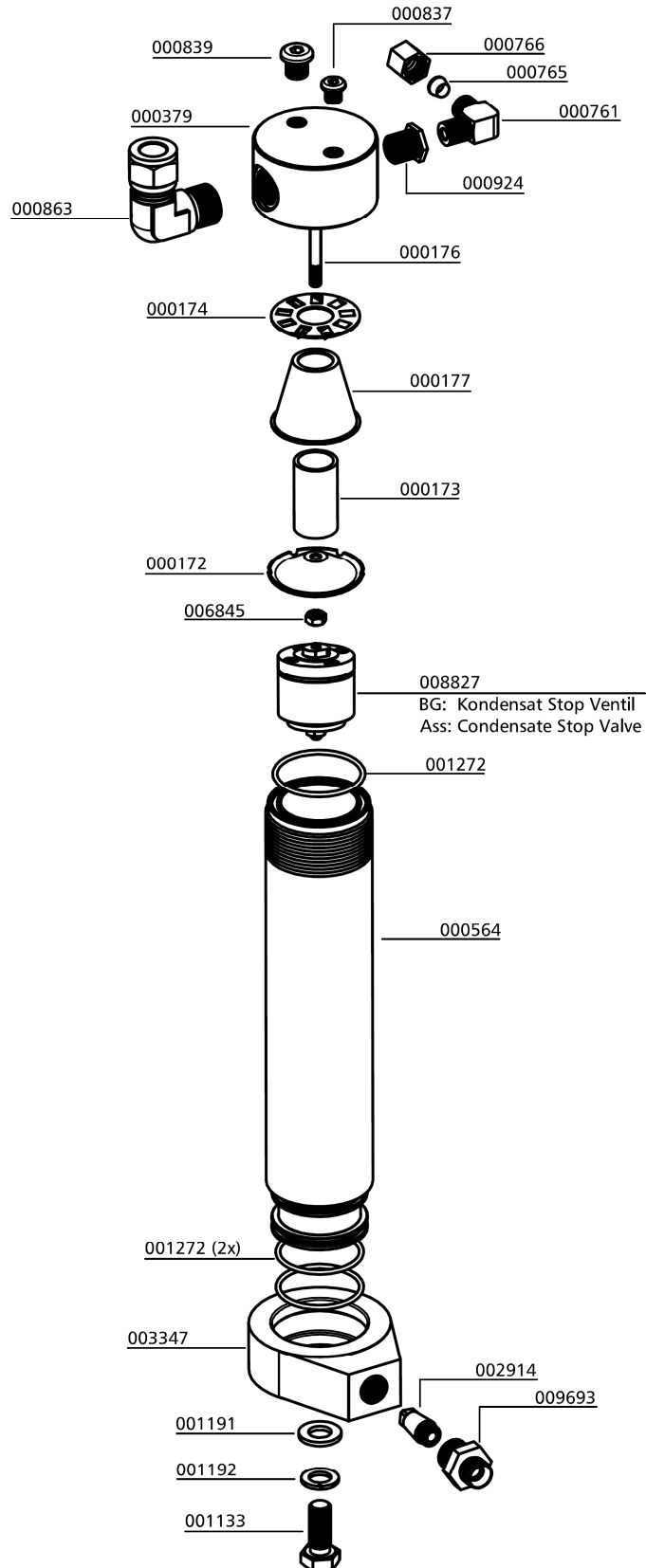

C





## ERSATZTEILLISTE / SPARE PART LIST

### Filter 0,8l / Filter 0.8ltr

Best.-Nr. / Order No.	Benennung	Description
000761	Verschraubung WE08LRFCX	Elbow Connection WE08LRFCX
000838	Verschlussstopfen VSTIR1/4EDCF	Plug VSTIR1/4EDCF
000921	Reduzierung R11/2X1/4CFX	Reducer R11/2X1/4CFX
001040	Zylinderschraube M8x20mm DIN912 8.8 ZN	Allen Screw M8x20mm DIN912 8.8 ZN
001158	Mutter M8 DIN934 ZN	Nut M8 DIN934 ZN
001181	U-Scheibe A8 DIN125 ZN	Washer A8 DIN125 ZN
001244	O-Ring Ø16 x 2 NBR70	O-Ring Ø16 x 2 NBR70
003980	Partikelfilterpatrone	Particle filter cartridge
003994	Filterbehälter 350 bar, 0,8 l, komplett	Filter case 350 bar, 0.8ltr, complete
003997	Filterstütze Partikelfilter 0,8 l	Filter support 0,8 ltr
004221	O-Ring, 54,2 x 3,0 FKM80	O-Ring, 54,2 x 3,0 FKM80
004222	Stützring 55,4x60x1,4	Back-up Ring 55,4x60x1,4
006363	Haltebügel Filtergehäuse 0,8 l	U-Clamp Filterhousing 0.8 ltr
006364	Halteschalen Filtergehäuse 0,8 l	Bracket Filter Housing 0.8 ltr
009031	Verschlussstopfen für CE-TÜV Sicherheitsventilsockel	Plug for CE Safety Valve Base

**DETAILANSICHT / DETAILED VIEW**

**Filter 0,8l / Filter 0.8ltr**

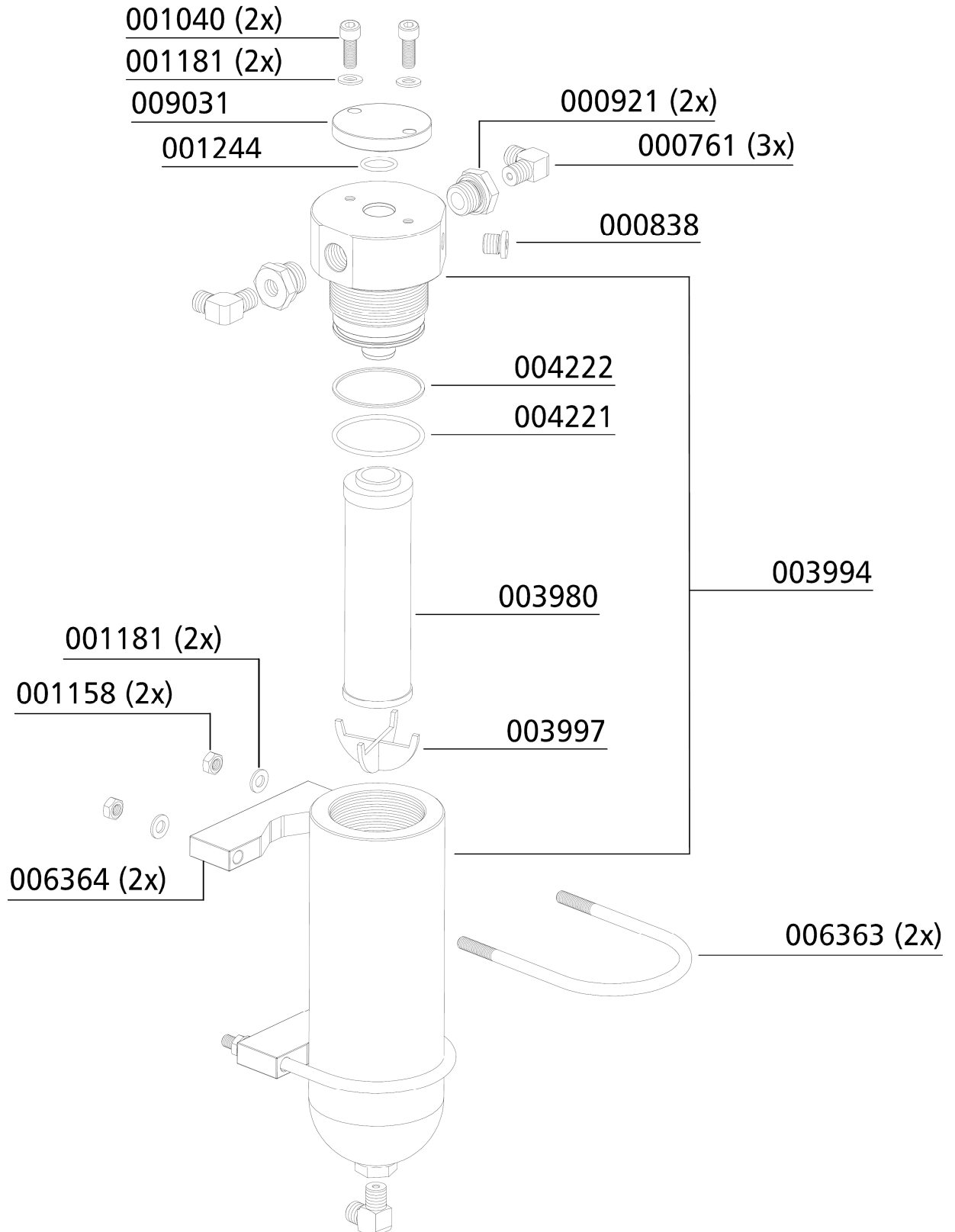

C

**Filtergehäuse 1,7 l / Filter Housing 1.7 ltr**

Best.-Nr. / Order No.	Benennung	Description
000002	Filterpatrone 1,7 l	Filter Cartridge 1.7 ltr
000272	Abstandshalter für Filtergehäuse	Spacer Bracket for Filtertower
000383	Messing Adapter	Brass Filter Adapter
000384	Düse Filtergehäuse	Jet Filter Housing
000761	Winkerverschraubung, WE08L/1/4"	Elbow Connection, WE08L/1/4"
000765	Schneidring PSR 08 LX	Olive Seal PSR 08 LX
000766	Mutter M08LCFX	Union Nut M08LCFX
001159	Stopfmutter, M8 DIN985 ZN	Lock Nut, M8 DIN985 ZN
001181	U-Scheibe A8 DIN125 ZN	Washer A8 DIN125 ZN
001285	Stützring, 63,96x4,65 NBR90, 350 bar, Filtergehäuse	Back-up Ring, 63,96x4,65 NBR90, 350 bar, Filter Housing
001287	O-Ring, 62,87 x 5,33 NBR90, Filtergehäuse	O-Ring, 62,87 x 5,33 NBR90, filter housing
002140	Filterschlüssel 1,7 & 2,3 Liter Behälter	Filter tool 1,7 & 2,3 Litre
002147	Haltebügel für Filtergehäuse, beidseitig M8X35mm	Holder for filter housing, M8X35mm (both sides)
002366	Filtergehäuse, 1,7l	Filter housing 1.7ltr
003077	Entwässerungsventil G1/4" AG	Drain valve G1/4" male
005244	O-Ring, 16 x 2,5 NBR90	O-Ring, 16 x 2,5 NBR90

**C**

**DETAILANSICHT / DETAILED VIEW**

**Filtergehäuse 1,7 l / Filter Housing 1.7 ltr**

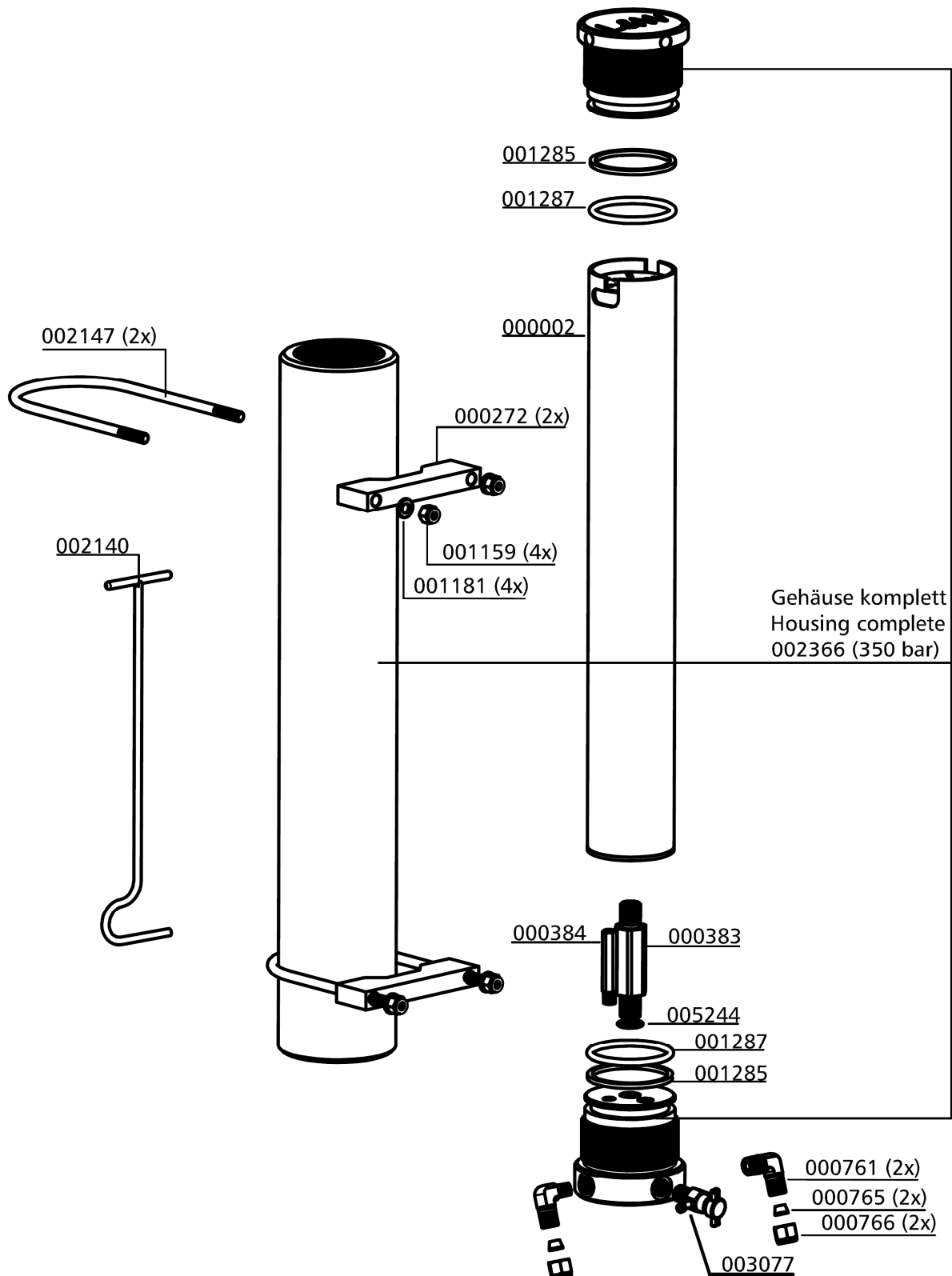

C

**Baugruppe: Kondensat-Stopp-Ventil-Gehäuse / Assembly: Housing Condensate-Stop-Valve**

Best.-Nr. / Order No.	Benennung	Description
000739	Verschraubung GE08L/1/4KEGCFX	Connection GE08L/1/4KEGCFX
000741	Verschraubung, GE08LR3/8CFX	Connection, GE08LR3/8CFX
000765	Schneidring PSR 08 LX	Olive Seal PSR 08 LX
000766	Mutter M08LCFX	Nut M08LCFX
001055	Zylinderschraube, M8x55mm DIN912 8.8 ZN	Allen Screw, M8x55mm DIN912 8.8 ZN
001184	Schnorr-Scheibe S8 N0110 ZN	Clamp Washer S8 S8 N0110 ZN
002914	Sinterfilter für Wasserabscheidersockel, M12x1,5mm AG	Sintered filt. water sep. Base, M12x1,5mm AG
006368	Behälter Kondensat-Stopp-Ventil	Container Condensate-Stop-Valve
006369	Behälterdeckel Kondensat-Stopp-Ventil	Cover Condensate-Stop-Valve
006382	O-Ring 38x3,5 NBR90	O-Ring 38x3,5 NBR90
008827	Kondensat-Stopp-Ventil Einsatz	Condensate-Stop-Valve Assembly
008828	Kondensat-Stopp-Ventil kompl., inkl. Ventileinsatz 008827	Condensate-Stop-Valve, compl., incl. valve assembly 008827

**C**

**DETAILANSICHT / DETAILED VIEW**

**Baugruppe: Kondensat-Stopp-Ventil-Gehäuse / Assembly: Housing Condensate-Stop-Valve**

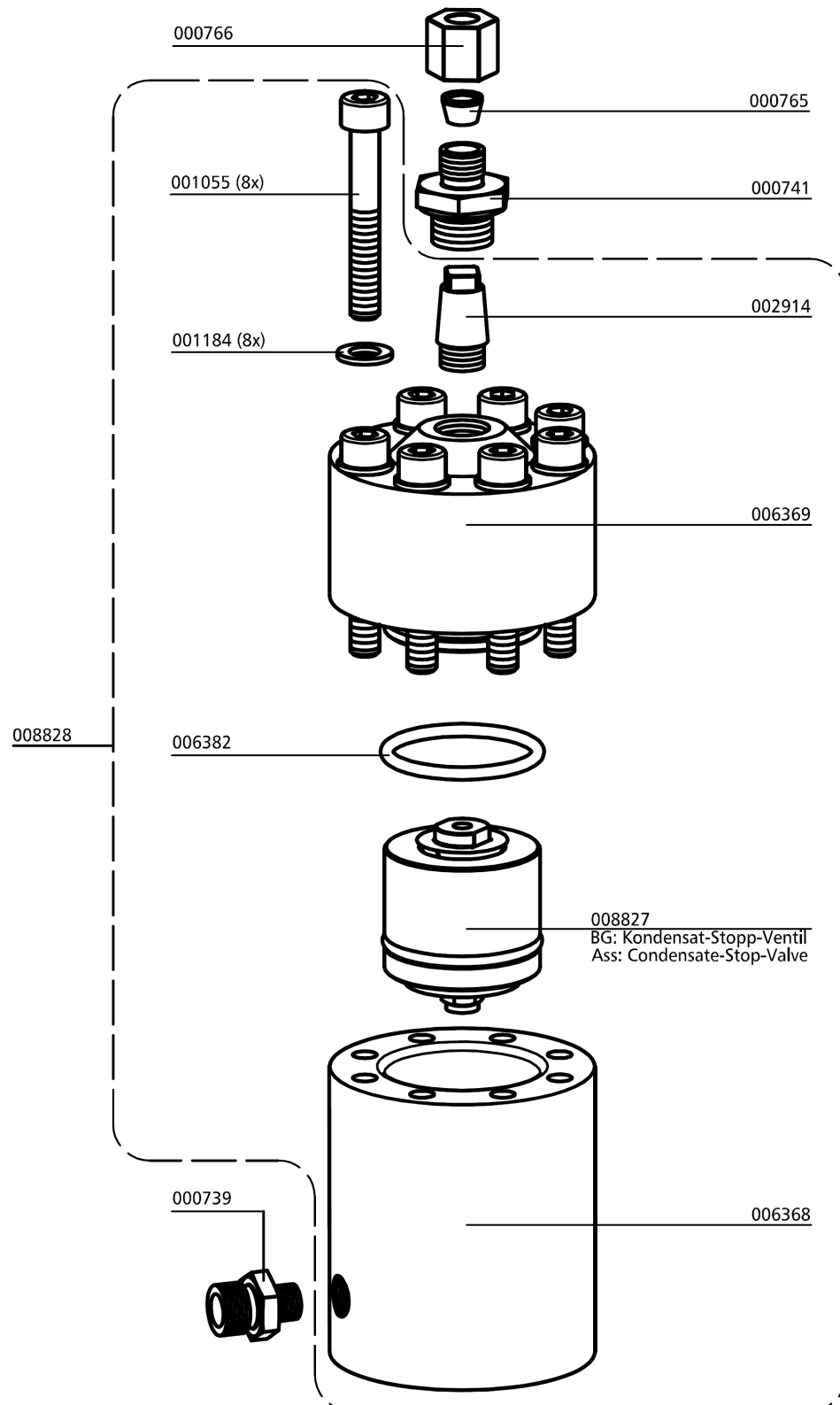

C



## ERSATZTEILLISTE / SPARE PART LIST

---

### Baugruppe: Kondensat-Stopp-Ventil / Assembly: Condensate-Stop-Valve

Best.-Nr. / Order No.	Benennung	Description
000498	U-Scheibe DIN 125 A6	Washer DIN 125 A6
001156	Stopfmutter M6 DIN985 ZN	Lock Nut M6 DIN985 ZN
001264	O-Ring, 38 x 3 NBR70	O-Ring, 38 x 3 NBR70
006370	Gehäuse Kondensat-Stopp-Ventil	Housing-Condensate-Stop-Valve
006372	Ventilkegel Kondensat-Stopp-Ventil	Valve Condensate Stop Valve
006373	Stauscheibe Kondensat-Stopp-Ventil	Baffle Plate Condensate Stop Valve
006380	Druckfeder	Compression Spring
008827	Kondensat-Stopp-Ventil Einsatz	Condensate-Stop-Valve Assembly

C

**DETAILANSICHT / DETAILED VIEW**

**Baugruppe: Kondensat-Stopp-Ventil / Assembly: Condensate-Stop-Valve**

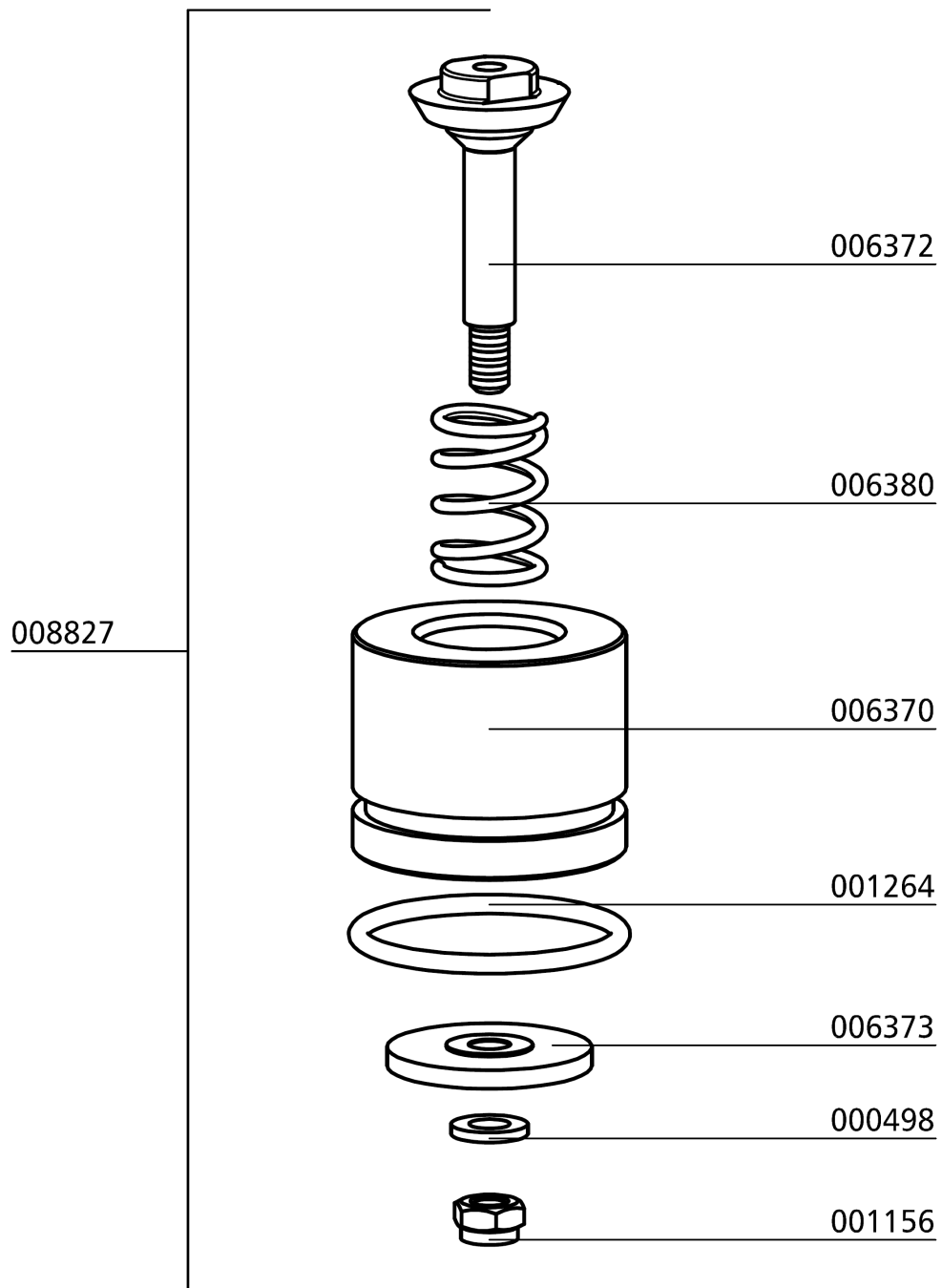

C





## ERSATZTEILLISTE / SPARE PART LIST

### Baugruppe: Kühler 1. Stufe / Assembly: Cooler 1st Stage

Best.-Nr. / Order No.	Benennung	Description
000568	Halterung	Bracket
001039	Zylinderschraube	Allen Screw
001058	Zylinderschraube M8x70mm DIN912 8.8 ZN	Allen Bolt
001159	Stopfmutter	Lock Nut M8
001181	U-Scheibe A8 DIN125 ZN	Washer A8
001205	4-kant Mutter	Square Nut M8
002106	Distanzbolzen M8xSW14x53mm	Spacer bolt M8xSW14x53mm
002995	Wärmetauscher 1. u. 2. Stufe, inkl. Mutter & Schneidring	Heat Exchanger 1st & 2nd Stage, c/w nut & olive seal ring
010303	Klemmschiene Wärmetauscher, l=380mm	Metal clamp bar for cooler, l=380mm
010863	PVC Schlauch, transparent	PVC Hose for Bracket

C

**DETAILANSICHT / DETAILED VIEW**

**Baugruppe: Kühler 1. Stufe / Assembly: Cooler 1st Stage**

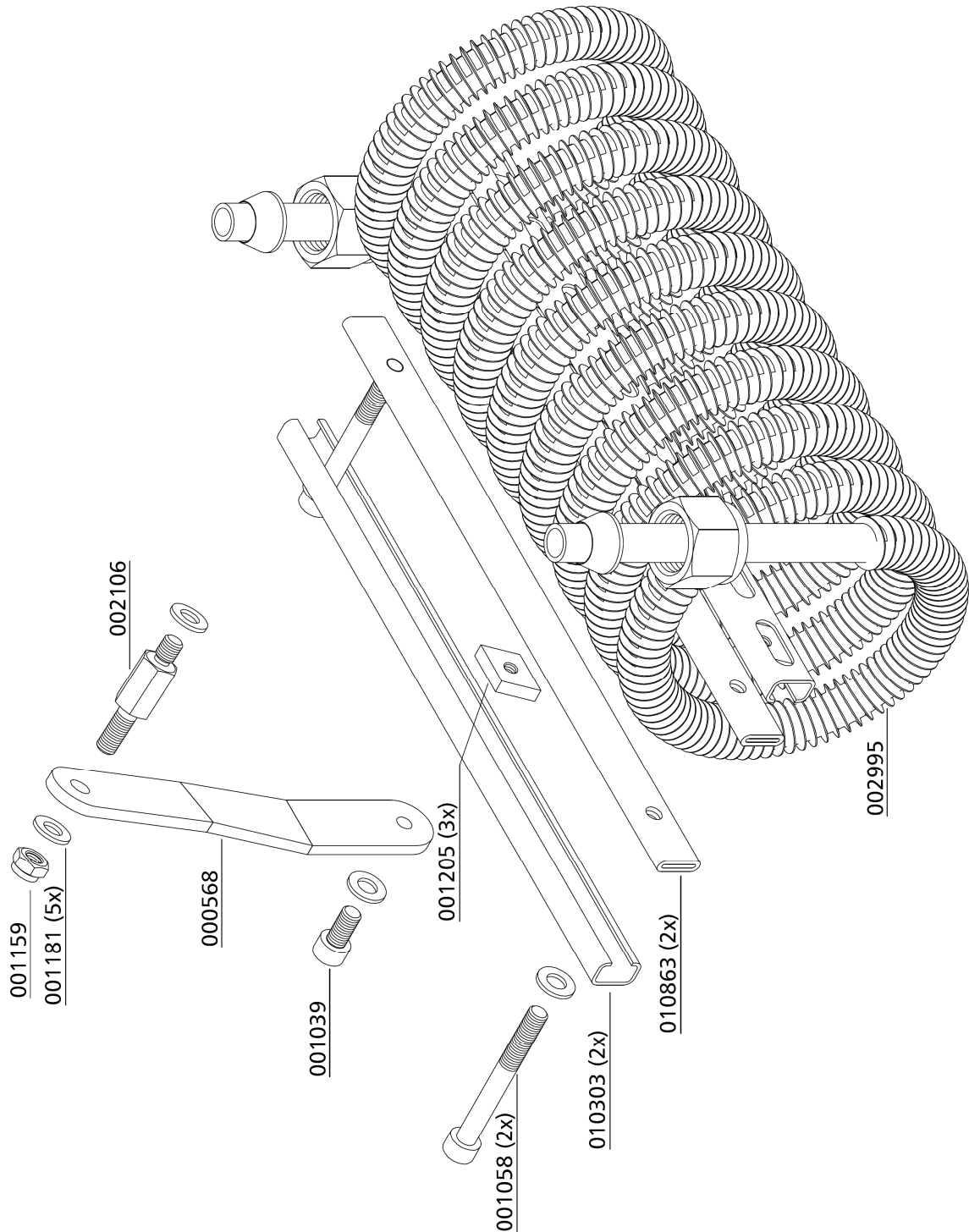

C



## ERSATZTEILLISTE / SPARE PART LIST

### Baugruppe: Kühler 2. Stufe / Assembly: Cooler 2nd Stage

Best.-Nr. / Order No.	Benennung	Description
000521	Klemmschiene Wärmetauscher, l=340mm	Metal clamp bar for cooler, l=340mm
000568	Halterung	Bracket
001039	Zylinderschraube	Allen Screw
001058	Zylinderschraube M8x70mm DIN912 8.8 ZN	Allen Bolt
001159	Stopfmutter	Lock Nut M8
001181	U-Scheibe A8 DIN125 ZN	Washer A8
001205	4-kant Mutter	Square Nut M8
002106	Distanzbolzen M8xSW14x53mm	Spacer bolt M8xSW14x53mm
002995	Wärmetauscher 1. u. 2. Stufe, inkl. Mutter & Schneidring	Heat Exchanger 1st & 2nd Stage, c/w nut & olive seal ring
010683	PVC Schlauch, transparent	PVC Hose for Bracket

C

**DETAILANSICHT / DETAILED VIEW**

**Baugruppe: Kühler 2. Stufe / Assembly: Cooler 2nd Stage**

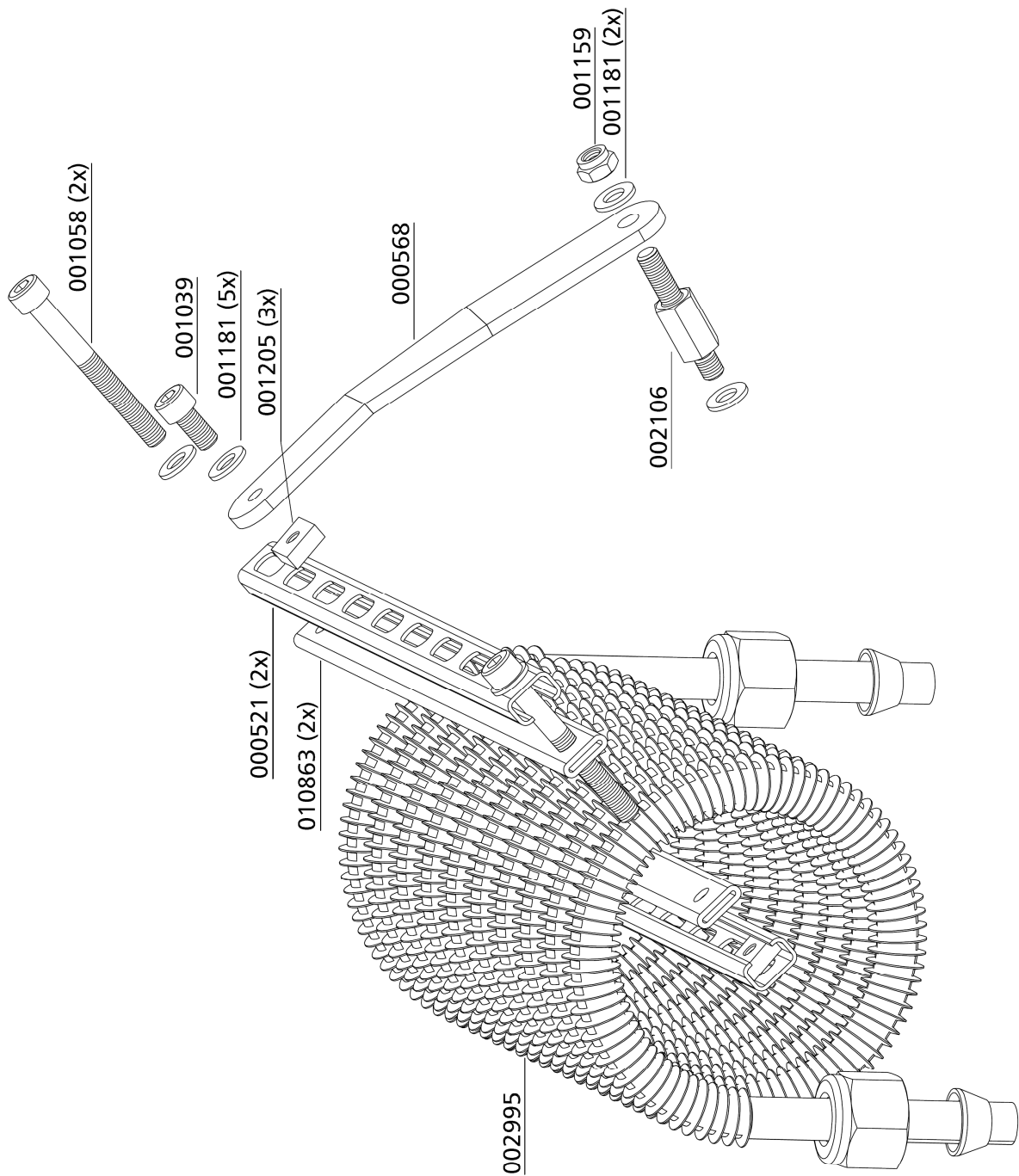

C



## ERSATZTEILLISTE / SPARE PART LIST

---

### Kühler 3. Stufe / Cooler 3rd Stage

Best.-Nr. / Order No.	Benennung	Description
000629	Doppelschelle 2 x 8mm 1 Paar	Pipe Clamp 2x8mm - 1 pair
000638	Doppelschelle 2 x 8 mm 1 Paar	Pipe Clamp 2x8mm 1pair
001026	Zylinderschraube M6x40mm DIN912 8.8 ZN	Allen Bolt M6x40mm DIN912 8.8 ZN
001028	Zylinderschraube M6x25mm DIN912 8.8 ZN	Allen Bolt M6x25mm DIN912 8.8 ZN
003224	Kühlerhalteblech	Bracket, Cooler Stage 3
003225	Kühlerhalteblech	Bracket, Cooler Stage 3
003226	Kühlrohr 3te Stufe kompl.	Cooler, 3rd stage kompl.
003574	Kühlspirale komplett inkl. Haltearme	Cooling coil (complete) incl. bracket

C

**DETAILANSICHT / DETAILED VIEW**

**Kühler 3. Stufe / Cooler 3rd Stage**

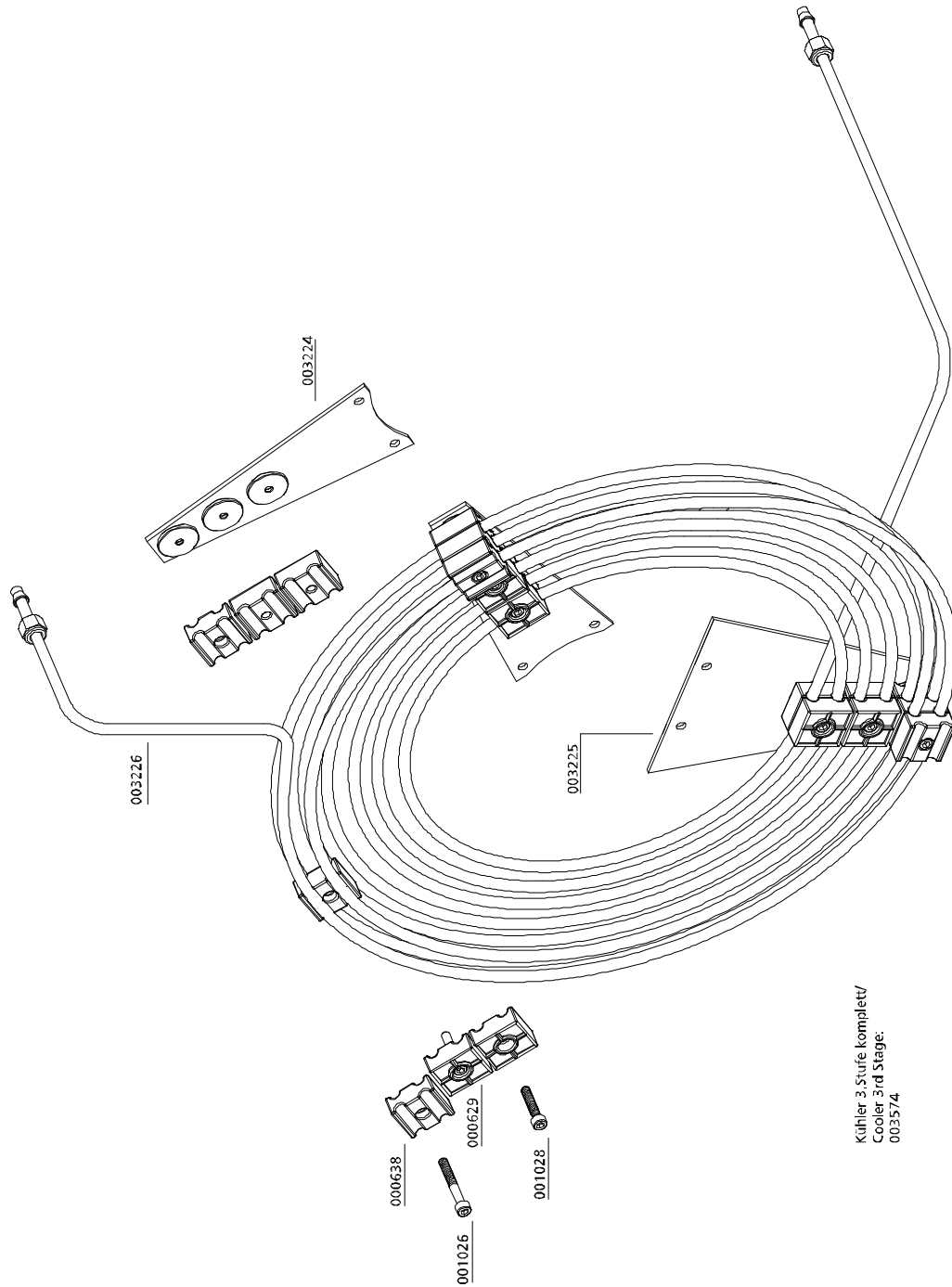

C



## ERSATZTEILLISTE / SPARE PART LIST

### Baugruppe: Zusatzkühler / Assembly: Additional Cooler

Best.-Nr. / Order No.	Benennung	Description
000498	U-Scheibe A6	Washer A6
000628	Einfachselle 1 x 8mm 1 Paar	Pipe Clamp 1x8mm 1pair PVC
000638	Doppelschelle 2 x 8 mm 1 Paar	Pipe Clamp 2x8mm 1pair
000735	Verschraubung G08LCFX	Connection G08LCFX
000765	Schneidring PSR 08 LX	Olive Seal PSR 08 LX
000766	Mutter M08LCFX	Nut M08LCFX
001013	Zylinderschraube M6x45mm DIN912 8.8	Allen Bolt M6x45mm DIN912 8.8 ZN
001027	Zylinderschraube M6x30mm DIN912 8.8	Allen Bolt M6x30mm DIN912 8.8 ZN
006400	Zusatzkühler, 3.Stufe, kompl.	Additional Cooler, 3rd Stage
006401	Befestigungsblech für Kühlrohrklemmen	Mounting sheet for clamps
006402	Kühlerrohr Zusatzkühler	Cooling Pipe Additional Cooler

C

**DETAILANSICHT / DETAILED VIEW**

**Baugruppe: Zusatzkühler / Assembly: Additional Cooler**

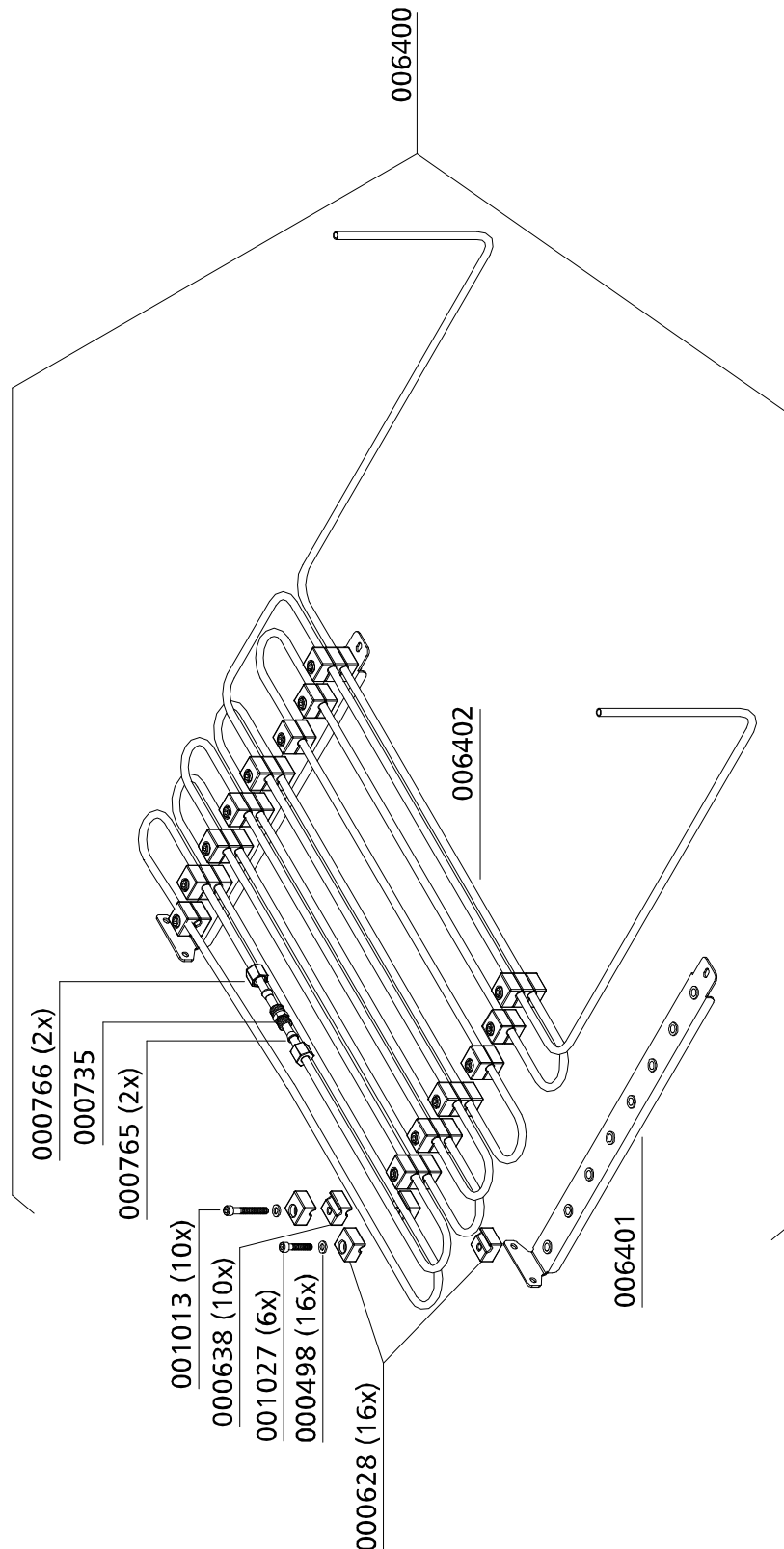

C





## ERSATZTEILLISTE / SPARE PART LIST

### Pneum. Kondensat-Ablassventil / Pneumatic Condensate Valve

Best.-Nr. / Order No.	Benennung	Description
000188	Sinterfilter, pneum. Kondensatventil	Sintered filter
000190	O-Ring Ø10 x 2,5 NBR90	O-Ring Ø10 x 2,5 NBR90
000191	Steuerkolben, pneum. Kondensatventil	Piston, pneumatic condensate valve
000192	O-Ring Ø13 x 2,5 NBR 90	O-Ring Ø13 x 2,5 NBR 90
000194	Reparatursatz pneum. Kondensatventil	Repair Kit Condensate Valve
000196	Düsenschraube, pneum. Kondensatventil	Inlet Jet Screw
000197	Stopfen, pneum. Kondensatventil	Plug
000198	Gehäuse, pneum. Kondensatventil	Body PCV
000199	Pneum. Kondensatventil	Pneumatic Condensate Valve
000498	U-Scheibe A6	Washer A6
000710	Verschraubung GE06LRFCX	Connection GE06LRFCX
000759	Verschraubung WE 08 LL R 1/8"	Elbow connection c/w nut&olive WE 08 LL R 1/8"
000799	Verschraubung mit fester Mutter EGE10L-REDA3C	Connection with fixed nut EGE10LREDA3C
001011	Zylinderschraube M6x60mm DIN912 8.8 ZN	Allen Bolt M6x60mm DIN912 8.8 ZN
006614	O-Ring Ø20 x 2 NBR90	O-Ring Ø20 x 2 NBR90

**DETAILANSICHT / DETAILED VIEW**

**Pneum. Kondensat-Ablassventil / Pneumatic Condensate Valve**

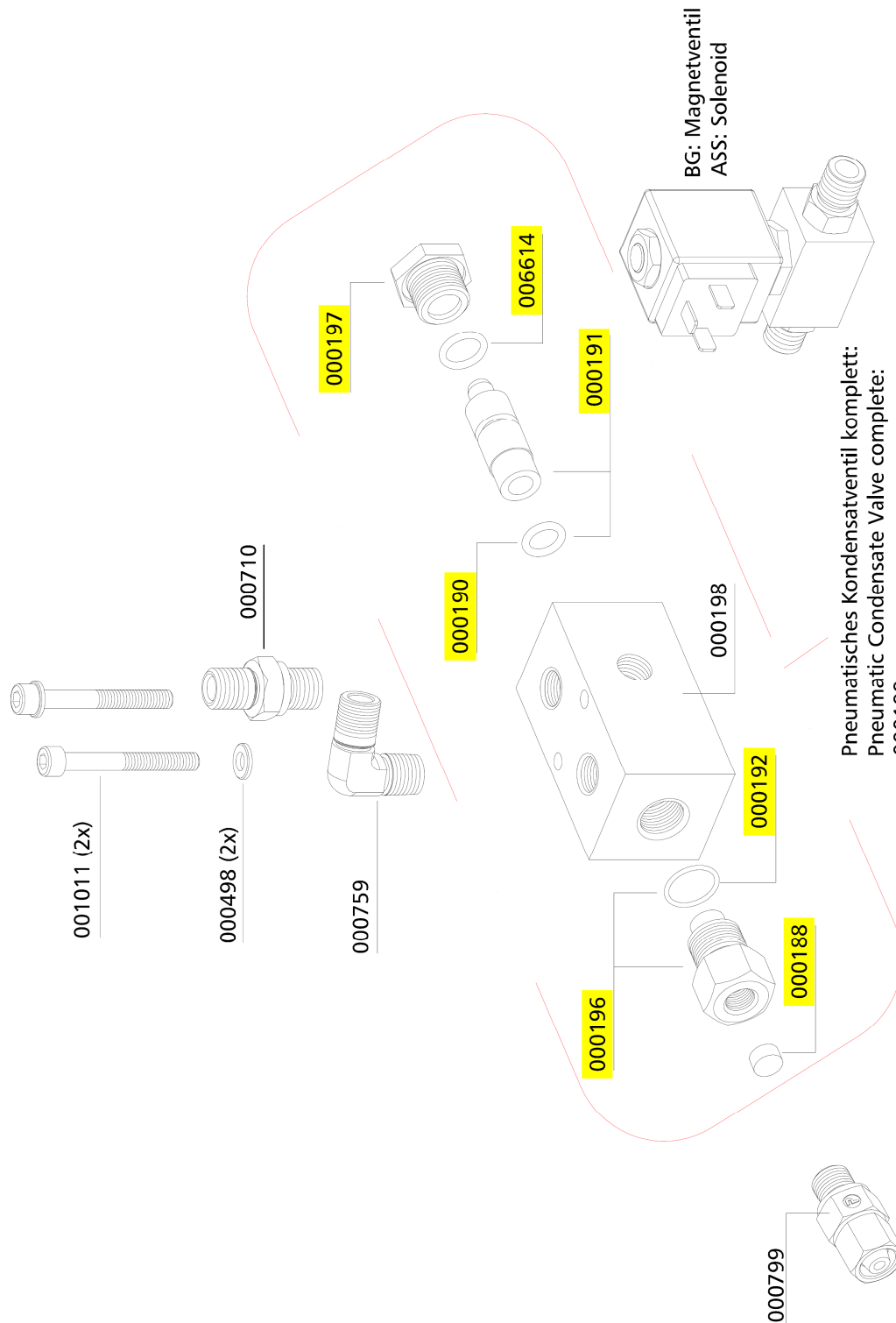

Pneumatisches Kondensatventil komplett:  
Pneumatic Condensate Valve complete:  
000199

Reparatursatz (bestehend aus gelb markierten Bestellnummern):  
Repair Set (consists of yellow marked P/N's):  
000194





## ERSATZTEILLISTE / SPARE PART LIST

### Druckhalteventil / Pressure Maintaining Valve

Best.-Nr. / Order No.	Benennung	Description
000169	Druckhalterückschlagventil, schwarz	Pressure Maint. Valve black
000498	U-Scheibe DIN 125 A6	Washer DIN 125 A6
000506	Feder	Spring
000508	USIT Ring 13,7 x Ø20 x 1,5	Gasket Ring U-Sit 13,7 x Ø20 x 1,5
000511	Mutter, Druckhalterückschlagventil	Lock Nut PMV
000512	Schraube, Druckhalte-Rückschlagventil	Set Bolt PMV
000513	Druckstück für Druckhalteventil,	Spring Adapter PMV, spring adapter
000514	Stift Druckhalte-/Rückschlagventil	Stud PMV
000515	Gehäuse, Druckhalte-Rückschlagventil	Main Body PMV
000516	Nutring, Druckhalterückschlagventil 5 x 10 x 5/2,5 90° Blau	Seal Ring PMV 5 x 10 x 5/2,5 90° blue
000517	Feder, Druckhalterückschlagventil	Coil Spring PMV
000518	Unterlegscheibe, Messing	Washer, Brass
000519	Dichtkappe, Druckhalte Rückschlagventil, schwarz	Plastic Seal Piston PMV, black
000520	Hohlschraube, DHRV	Inlet Jet PMV
000765	Schneidring PSR 08 LX	Olive Seal PSR 08 LX
000767	Mutter 08 S	Union Nut 08 S
001023	Zylinderschraube	Allen Bolt

## DETAILANSICHT / DETAILED VIEW

### Druckhalteventil / Pressure Maintaining Valve

**Reparatursatz  
003548:**

Bestehend aus:  
Gelbmarkierte  
Bestellnummern

**Repair kit  
003548:**

Consists of:  
Yellow marked  
P/N's

000169 (complete)

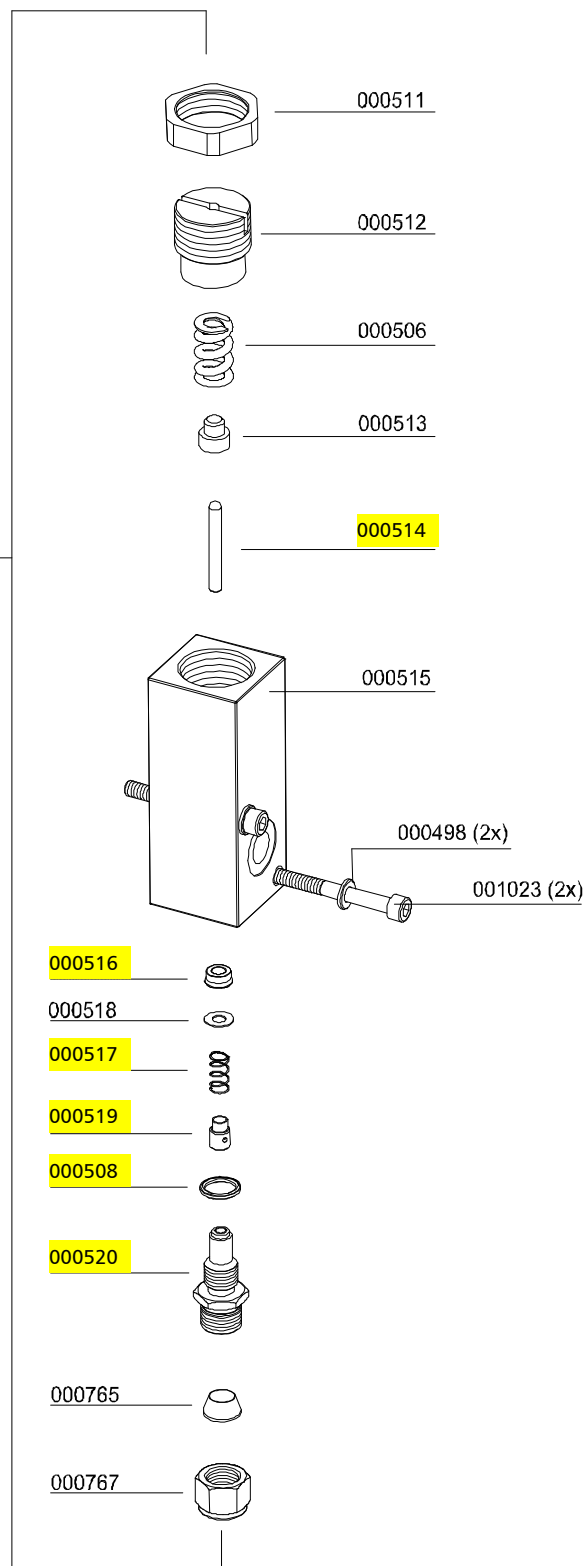

C



## ERSATZTEILLISTE / SPARE PART LIST

### Druckschalter / Pressure Switch

Best.-Nr. / Order No.	Benennung	Description
000203	Druckschalter, G1/4" IG, PV 50 - 350 bar	Pressure Switch, G1/4" female 50-350 bar
000216	Halteklotz, Alu	Alloy Fixing Block, alloy
000738	Verschraubung, GE08LRFCX	Connection, GE08LRFCX
000749	Verschraubung mit fester Mutter, EVGE 08 PLR-ED	Connection with fixed nut, EVGE 08 PLR-ED
000761	Winkelverschraubung, WE08LRA3CX	Elbow Connection, WE08LRA3CX
000765	Schneidring, PSR 08 LX	Olive Seal, PSR 08 LX
000766	Mutter, M08LCFX	Nut, M08LCFX
000783	Verschraubung, GE10L - R1/4"	Straight Connection, GE10L - R1/4"
000857	Reduzierung mit fester Mutter, RED 08/06L	Reducer with fixed nut, RED 08/06L
001026	Zylinderschraube, M6x40mm DIN912	Allen Bolt, M6x40mm DIN912 8.8 ZN

C

**DETAILANSICHT / DETAILED VIEW**

**Druckschalter / Pressure Switch**

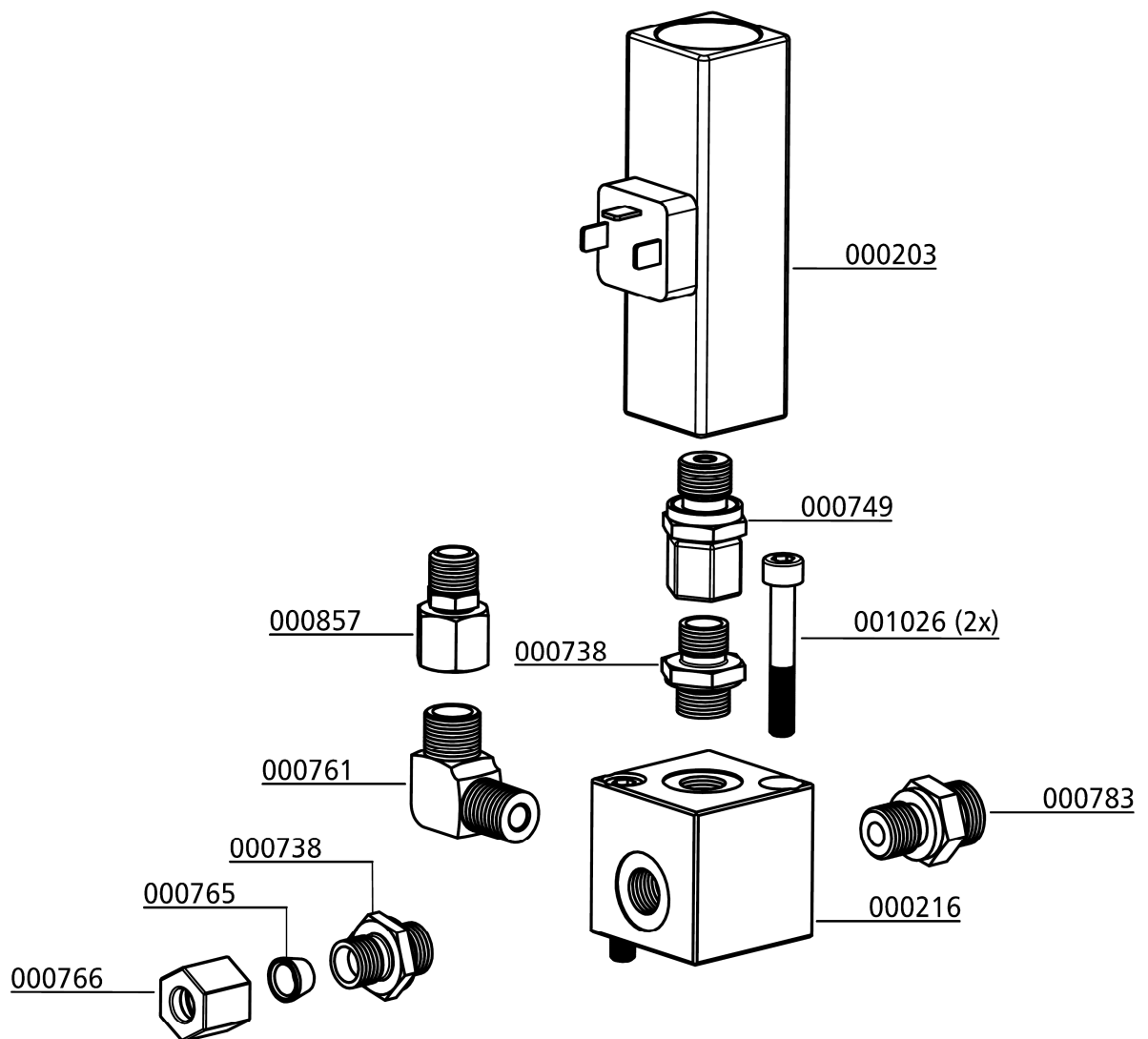

C



## ERSATZTEILLISTE / SPARE PART LIST

---

### Magnetventile / Solenoid Valves

Best.-Nr. / Order No.	Benennung	Description
000738	Verschraubung	Connection
000799	Verschraubung	Connection with fixed nut
000892	Doppelnippel	Double Nipple
001546	Aludichtring für Magnetventile G1/4"	Alloy Seal Ring for G1/4" male
006113	Magnetventil 0-55 bar	Solenoid 0-55 bar

C

**Magnetventile / Solenoid Valves**

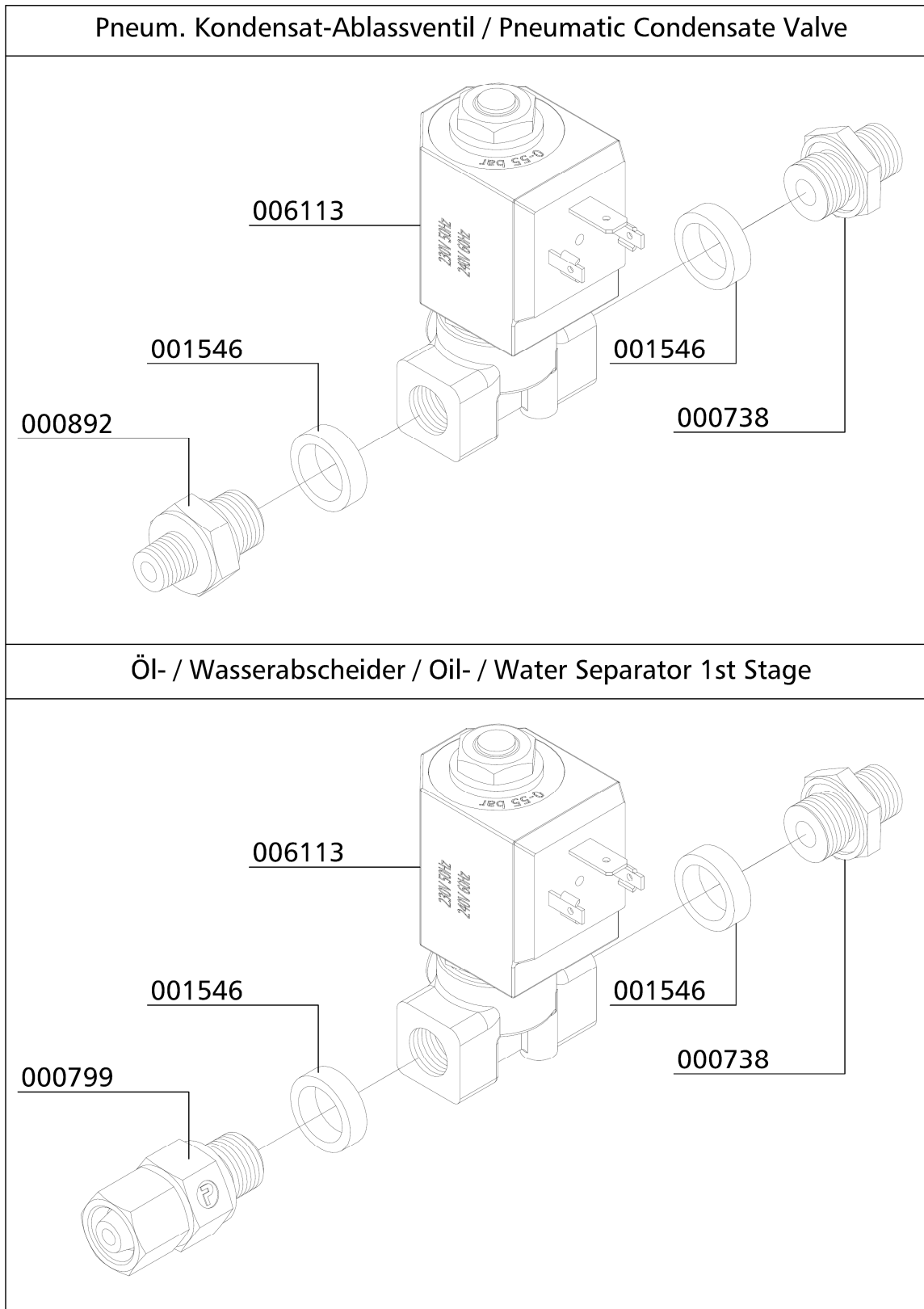

C





## ERSATZTEILLISTE / SPARE PART LIST

### Magnetventil mit Rückschlagventil / Solenoid valve with non-return valve

Best.-Nr. / Order No.	Benennung	Description
000741	Verschraubung, GE08LR3/8EDOMDA3C	Connection, GE08LR3/8EDOMDA3C
000749	Verschraubung mit fester Mutter, EVGE 08 PLR-ED	Connection with fixed nut, EVGE 08 PLR-ED
000751	Verschraubung, TE08LR3CFX	Connection, TE08LR3CFX
000899	Schottverschraubung, SV08LOMDA3C	Bulkhead fitting, SV08LOMDA3C
001198	Schnorr Scheibe, S14 N0110 ZN,	Clamp washer, S14 N0110 ZN,
001472	Magnetventil, Edelstahl, 350bar 230V/50Hz	Solenoid, s/s, 350 bar 230V/50Hz
001546	Aludichtring für Magnetventile G1/4"	Alloy seal ring for G1/4" male
003159	Sinterfilter G1/4" mit Schlitz	Sintered filter G1/4" with slot
003707	Rückschlagventil, Stahl, 2 x G3/8"	Non-return valve, steel, 2 x G3/8"
005838	U-Scheibe, A15 DIN433 ZN	Washer, A15 DIN433 ZN
010493	Rohrleitung Ø8mm, komplett mit M.&S.	Pipe Ø8mm, c/w nuts and olive seal
010494	Rohrleitung Ø8mm, komplett mit M.&S.	Pipe Ø8mm, c/w nuts and olive seal

**ERSATZTEILLISTE / SPARE PART LIST**

**Magnetventil mit Rückschlagventil / Solenoid valve with non-return valve**

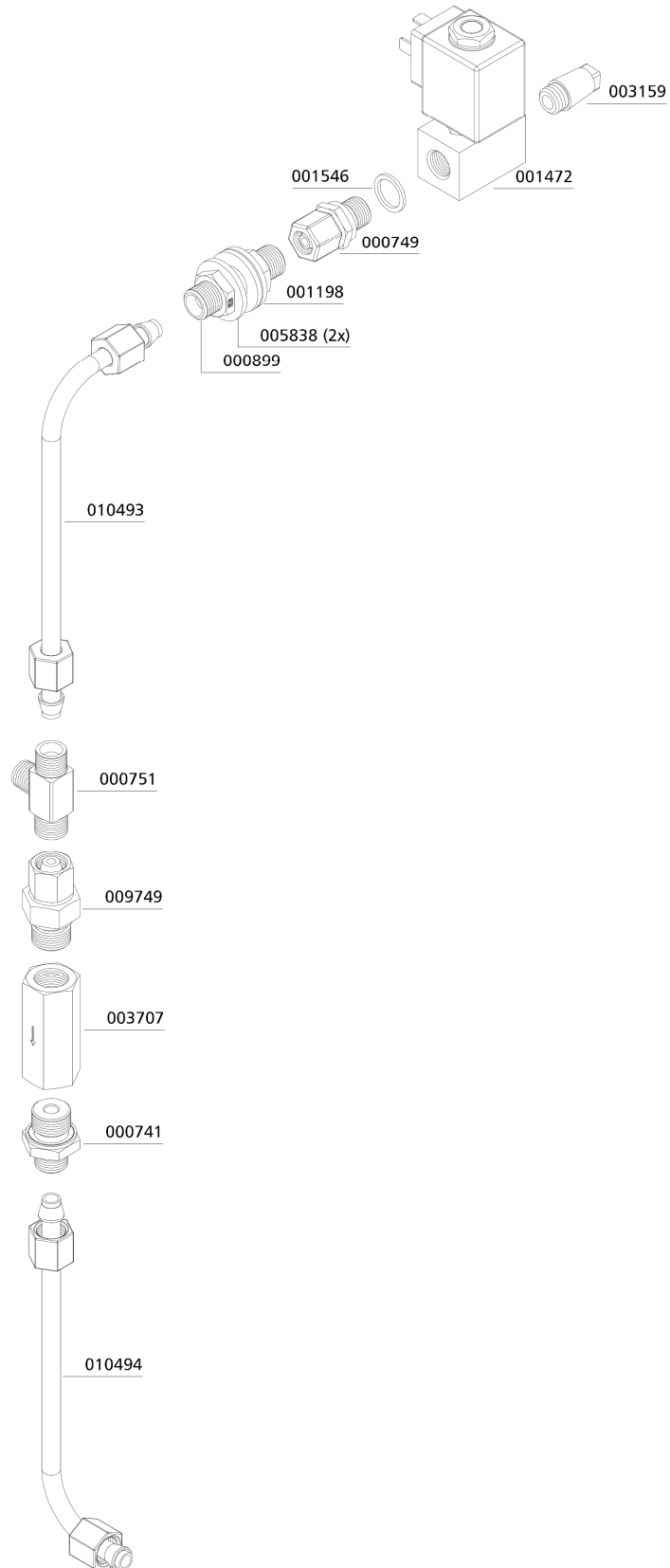

C

**Sicherheitsventil / Safety Valve**

Best.-Nr. / Order No.	Benennung	Description
000233	Sockel für Sicherheitsventil mit TÜV, x G1/4" seitlich 180°	Base for Safety Valve TÜV type
000553	Sicherheitsventil 225bar mit TÜV	Safety Valve 225bar c/w TÜV
000554	Sicherheitsventil 250bar mit TÜV	Safety Valve 250bar c/w TÜV
000555	Sicherheitsventil 300bar mit TÜV	Safety Valve 300bar c/w TÜV
000556	Sicherheitsventil 330bar mit TÜV	Safety Valve 330bar c/w TÜV
000557	Sicherheitsventil 350bar mit TÜV	Safety Valve 350bar c/w TÜV
000738	Verschraubung GE08LRCFX	Connection GE08LRCFX
000765	Schneidring PSR 08 LX	Olive Seal PSR 08 LX
000766	Mutter M08LCFX	Nut M08LCFX
000838	Verschlussstopfen VSTIR1/4EDCF	Plug VSTIR1/4EDCF
001044	Zylinderschraube	Allen Bolt
001058	Zylinderschraube	Allen Bolt
001158	Mutter	Nut
001181	U-Scheibe	Washer
001244	O-Ring, Flansch Sicherheitsventil	O-Ring, Flange Safety Valve
001814	Sicherheitsventil 225bar mit CE	Safety Valve 225bar with CE
001815	Sicherheitsventil 250bar mit CE	Safety Valve 250bar with CE
001816	Sicherheitsventil 330bar mit CE	Safety Valve 330bar with CE
001817	Sicherheitsventil 350bar mit CE	Safety Valve 350bar with CE

## DETAILANSICHT / DETAILED VIEW

### Sicherheitsventil / Safety Valve

Druck/ Pressure	SV-Ventil mit CE-Prüfung/ Safety Valve with CE	SV-Ventil mit TÜV-Prüfung/ Safety Valve with TÜV
225 bar	001814	000553
250 bar	001815	000554
285/300 bar	-----	000555
330 bar	001816	000556
350 bar	001817	000557

Sonder-Einstelldrücke auf Anfrage! /  
Special relieve pressures are available on request!

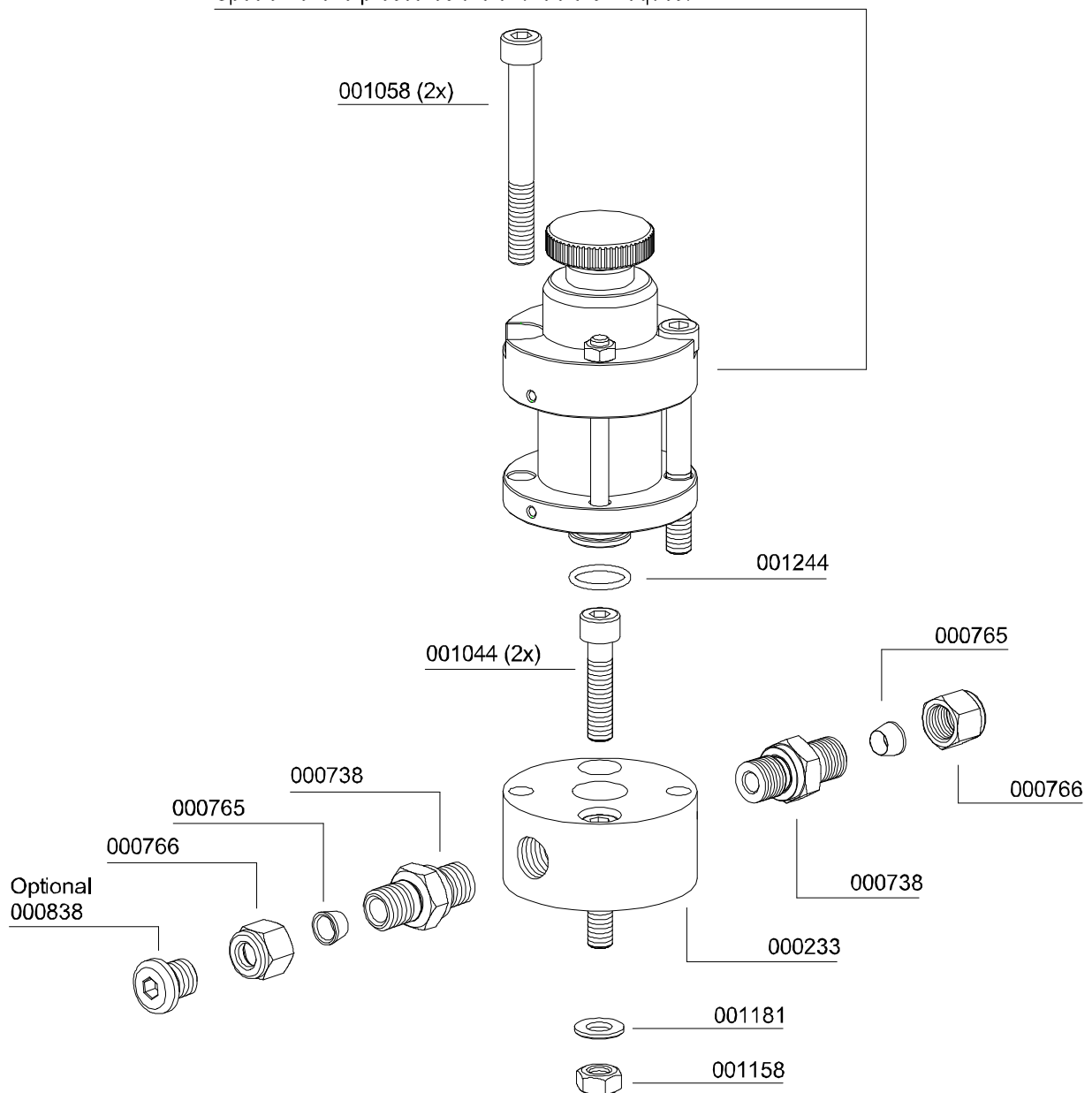



## ERSATZTEILLISTE / SPARE PART LIST

---

### Baugruppe: Ansaugfilter / Intake Filter

Best.-Nr. / Order No.	Benennung	Description
000170	Ansaugfilterpatrone	Air Intake Filter Cartridge
001772	Flügelmutter, PVC-schwarz	Winged Nut, PVC black
001782	O-Ring, Ansaugfiltergehäuse	O-Ring, Intake Filter Housing
009652	Gehäuse für Ansaugfilter	Intake Filter Housing
009653	Deckel für Ansaugfilter	Cover Intake filter housing
009658	O-Ring	O-Ring

C

**DETAILANSICHT / DETAILED VIEW**

---

**Baugruppe: Ansaugfilter / Intake Filter**

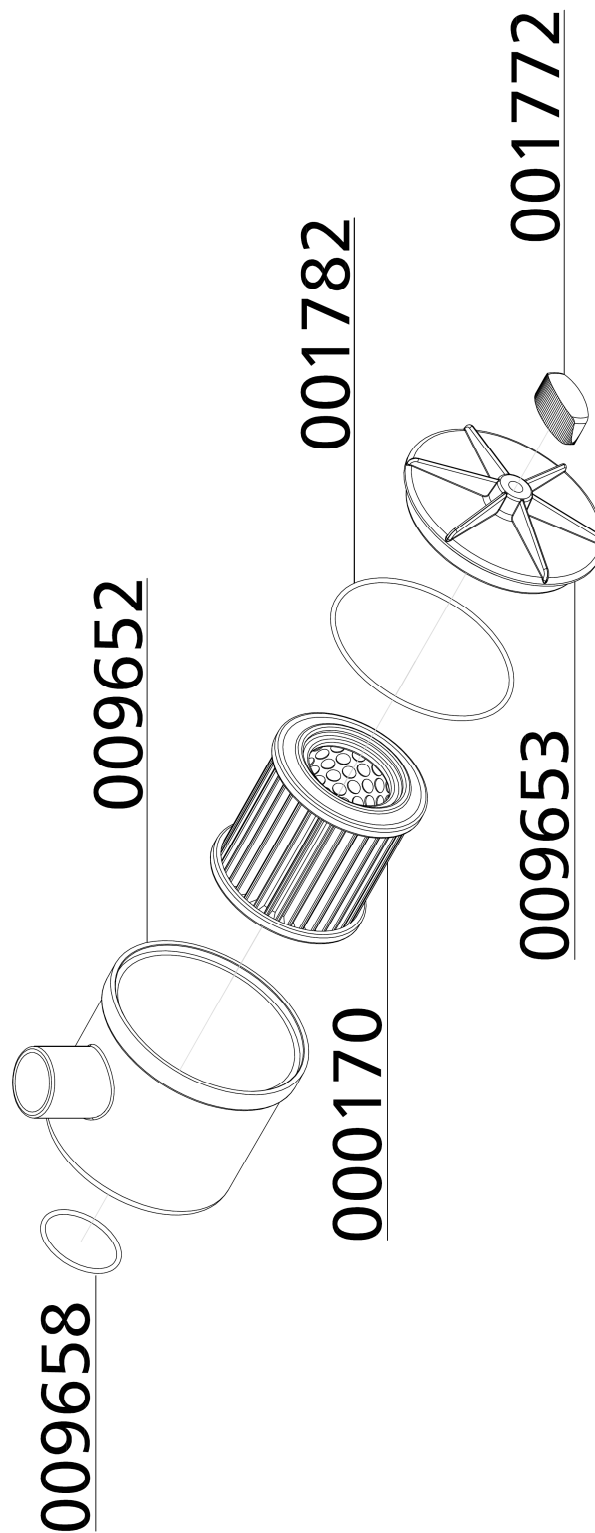

C

**Baugruppe: Kondensat-Sammelbehälter / Assembly: Housing Condensate-Catch-Tank**

Best.-Nr. / Order No.	Benennung	Description
000739	Verschraubung GE08L/1/4KEGCFX	Connection GE08L/1/4KEGCFX
000779	Verschlussstopfen 1/4" HHP-S	Plug 1/4" HHP-S
001179	U-Scheibe A6 M0030 ZN	Washer A6 M0030 ZN
002152	O-Ring 80x2,5 NBR70	O-Ring 80x2,5 NBR70
005842	Linsenflanschschraube mit Innensechskant M6x16 mm, DIN 7380F, 10.9	Lens Head Screw M6x16 mm, DIN 7380F, 10.9
006106	Linsenflanschschraube mit Innensechskant M6x10 mm - DIN7380, Zn	Socket Button Head M6x10 mm - DIN7380, Zn
006356	Kondensatbehälter 10 Liter	Condensate Catch Tank 10 Litre
006379	Zugfeder Kondensatfilterpatrone	Spring Condensate Filter Cartr
006459	Adapter Kondensatbehälter	Adapter Condensate Catch Tank
006460	Federspannblech Kondensatbehälter	Spring Clamping Plate CCT
006461	Halteblech Kondensatbehälter	Bracket Condensate Catch Tank
006462	Filter Kondensatbehälter	Filter Condensate Catch Tank
008357	Verschlusskappe für 006356	Cap for Condensate Catch Tank 006356
009995	Kondensatschlauch, Ø8x1,5, L: 565mm	Condensate Hose Ø8x565mm
009996	Kondensatschlauch, Ø8x1,5, L: 580mm	Condensate Hose Ø8x580mm
009997	Kondensatschlauch, Ø8x1,5, L: 612mm	Condensate Hose Ø8x612mm

**C**

**DETAILANSICHT / DETAILED VIEW**

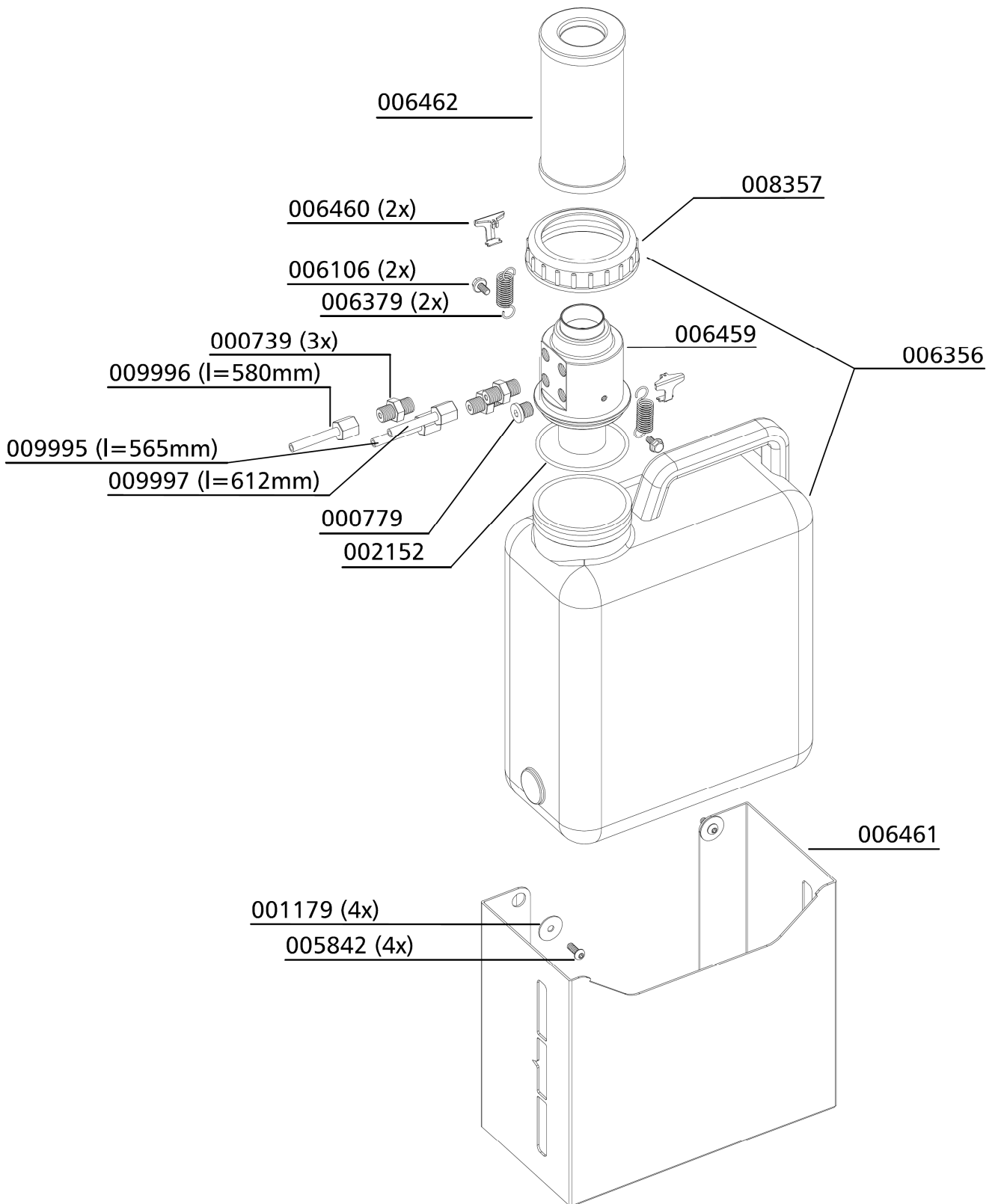

C





## ERSATZTEILLISTE / SPARE PART LIST

---

### Baugruppe: Verteilerblock / Assembly: Distributor Block

Best.-Nr. / Order No.	Benennung	Description
000738	Verschraubung, GE08LRFCX	Connection, GE08LRFCX
000764	Verschraubung, EVW08LOMDCF	Connection, EVW08LOMDCF
005842	Linsenflanschschraube mit Innensechskant, M6x16 mm, DIN 7380F, 10.9	Lens Head Screw, M6x16 mm, DIN 7380F, 10.9
006464	Verteilerblock Kondensatentwässerung	Distributor Block CD

C

**DETAILANSICHT / DETAILED VIEW**

---

**Baugruppe: Verteilerblock / Assembly: Distributor Block**

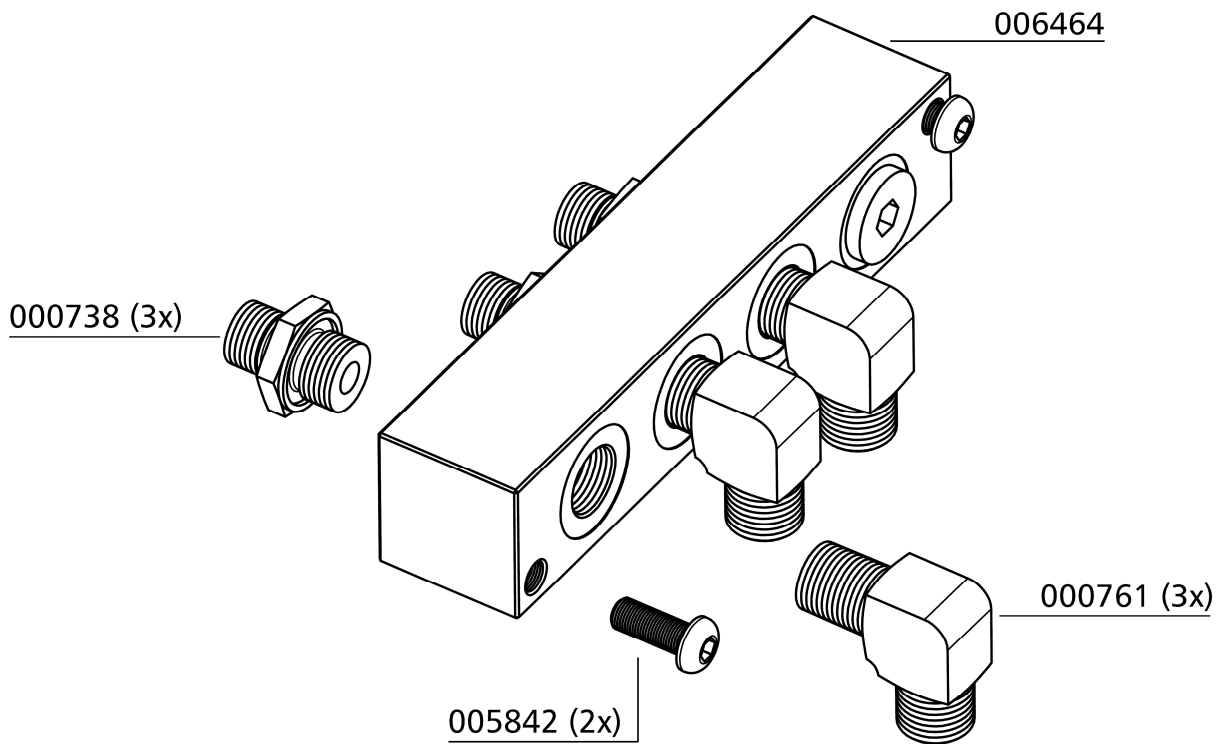



## ERSATZTEILLISTE / SPARE PART LIST

### Ölpumpe / Oil Pump

Best.-Nr. / Order No.	Benennung	Description
000208	Ölpumpenantriebsflansch	Drive Flange Oil Pump
000498	U-Scheibe DIN 125 A6	Washer DIN 125 A6
000710	Verschraubung GE06LRFCX	Connection GE06LRFCX
000712	Verschraubung GE06LR1/4CFX	Connection GE06LR1/4CFX
000759	Verschraubung WE 08 LL R 1/8"	Elbow connection WE 08 LL R 1/8"
000761	Winkelverschraubung WE08LRA3CX	Elbow Connection WE08LRA3CX
000783	Verschraubung GE10L - R1/4"	Straight Connection GE10L - R1/4"
000837	Verschlussstopfen VSTI R1/8" ED	Plug VSTI R1/8" ED
000838	Verschlussstopfen VSTIR1/4EDA3C	Plug VSTIR1/4EDA3C
000895	Doppelnippel G1/2" FF33MS	Double Nipple G1/2" FF33MS
000921	Reduzierung RI1/2X1/4CFX	Reducer RI1/2X1/4CFX
000958	Gewindestift M8x16mm DIN914, 5.8 ZN	Worm Screw M8x16mm DIN914 5.8 ZN
001014	Gewindestift mit Zapfen M6X14mm DIN915	Allen Screw with Pin M6X14mm DIN915
001027	Zylinderschraube M6x30mm DIN912 8.8 ZN	Allen Bolt M6x30mm DIN912 8.8 ZN
001045	Zylinderschraube M8x45mm DIN912 8.8 ZN	Allen Screw M8x45mm DIN912 8.8 ZN
001159	Stopfmutter M8 DIN985 ZN	Lock Nut M8 DIN985 ZN
001181	U-Scheibe A8 DIN125 ZN	Washer A8 DIN125 ZN
002340	O-Ring Ölpumpenflansch 32,2x3 NBR70	O-Ring, oil pump flange 32,2x3 NBR70
008851	Ölpumpenflansch	Oil Pump Flange
008872	O-Ring 72-2 NBR70 RX	O-Ring 72-2 NBR70 RX
009183	Halter Ölverteilerblock	Bracket oil distributor block
009241	Öldruckleitung Ø10mm, LW 450 / 530 / 570	Oil Suction Pipe, LW 450 / 530 / 570
009242	Öldruckleitung Ø8mm	Oil Suction Pipe Ø8mm
009371	Ölverteilerblock	Oil distributor block
009445	Niederdruckfilter, 10 bar	Low-Pressure Filter, 10 bar
009446	Anschraubpatrone	Screw on Cartridge
009498	Öldruckleitung Ø6mm	Oil Suction Pipe Ø6mm
009500	Öldruckleitung Ø6mm	Oil Pressure Pipe Ø6mm
009610	Ölpumpe	Oil Pump

# DETAILANSICHT / DETAILED VIEW

## Ölpumpe / Oil Pump

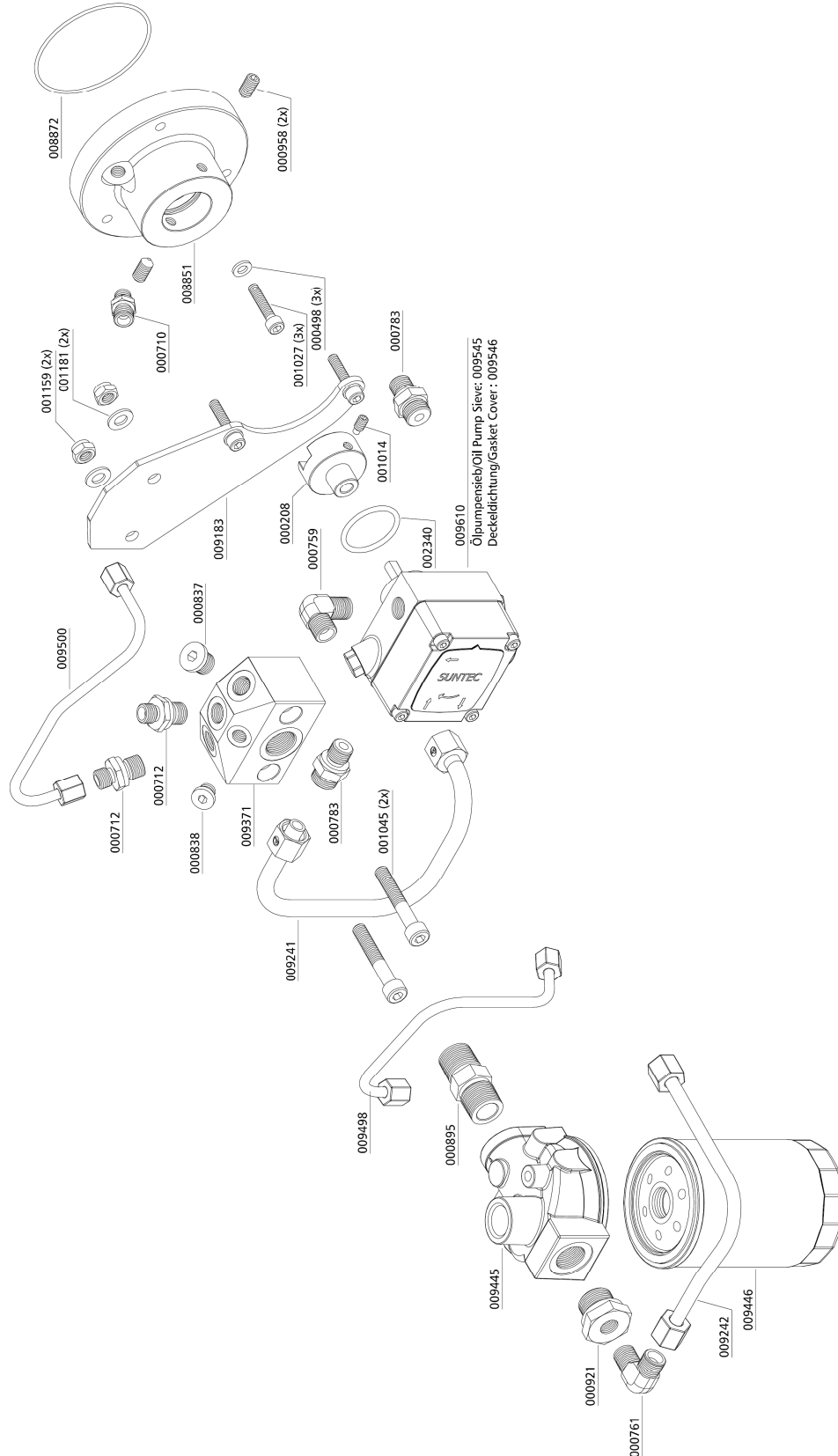

C



## ERSATZTEILLISTE / SPARE PART LIST

---

### Baugruppe: Ölablassschlauch / Assembly: Oil Drainage Tube

Best.-Nr. / Order No.	Benennung	Description
000817	Verschraubung	Connection
001548	Verschraubung	Connection
008655	Linsenflanschschraube mit Innensechskant M6x12 mm, DIN 7380F, 10.9	Lens Head Screw M6x12 mm, DIN 7380F, 10.9
008670	Ölablassschlauch inkl. Kugelhahn	Oil drain hose c/w ball valve
008671	Ölablassschlauch	Oil drain hose
009772	Halter Öl-Ablassschlauch	Holder Oil drain hose

C

**DETAILANSICHT / DETAILED VIEW**

---

**Baugruppe: Ölablassschlauch / Assembly: Oil Drainage Tube**

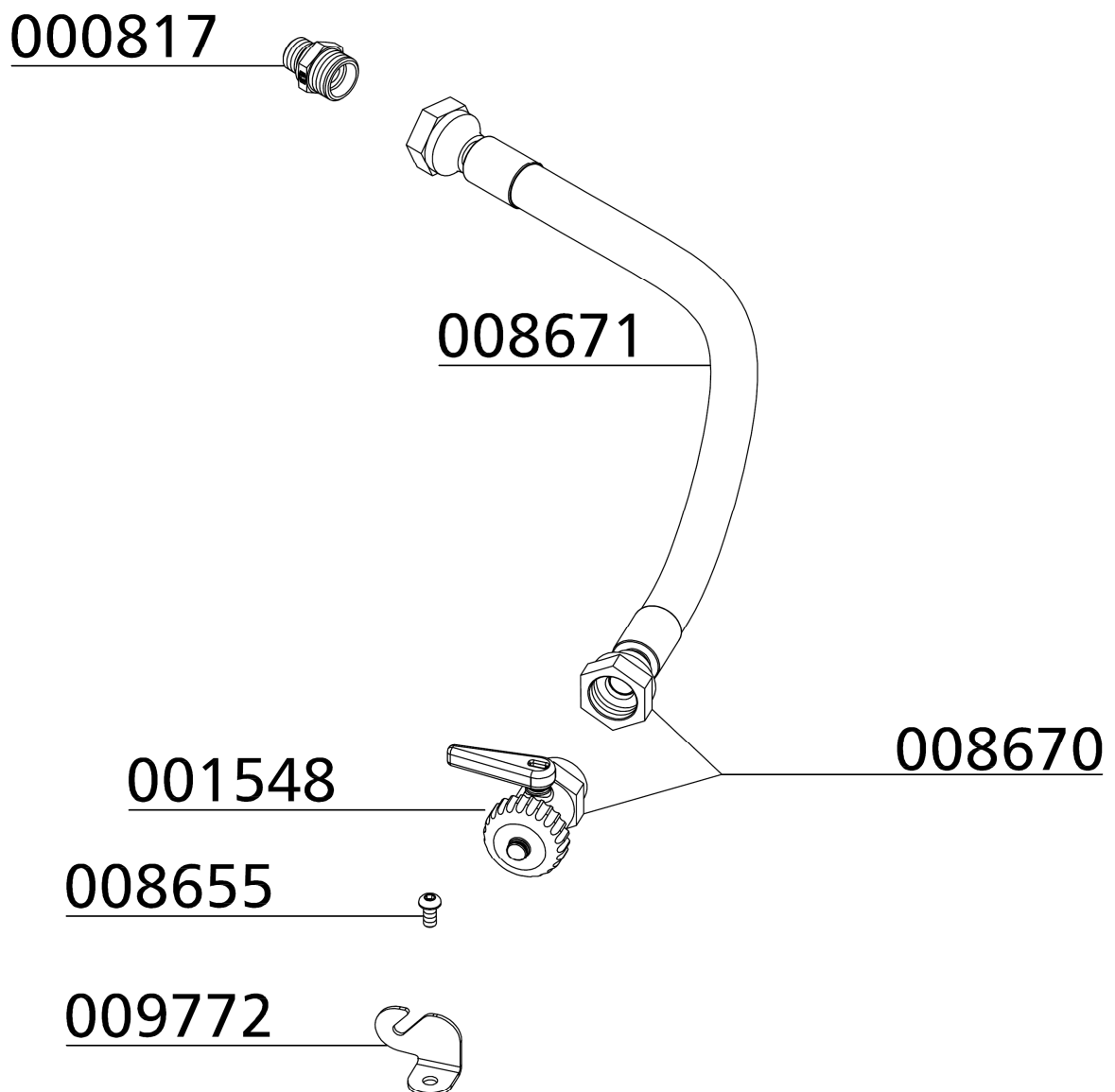

C



## ERSATZTEILLISTE / SPARE PART LIST

### Motor / Motor

Best.-Nr. / Order No.	Benennung	Description
001129	Schlossschraube M12x40mm DIN603 8.8 ZN	Carriage Bolt M12x40mm DIN603 8.8 ZN
001165	Mutter M12	Nut M12
001191	U-Scheibe A12	Washer A12
001192	Federring A12	Spring Washer A12
002872	Antriebsmotor 11 kW 230 V 50/60 Hz	Drive motor 11kW 230V(50/60Hz)
002974	Antriebsmotor 11 kW / 400V 50/60Hz	Drive Motor 11kW 400V 50/60Hz
003175	Passfeder (Motor) LW 300/450	Woodruff Key (motor)
008519	Spannbuchse Ø38 mm für Riemenscheibe	Pulley Clamp Bush Ø38 mm
008797	Elektromotor 400V / 50 Hz, 7,5kW, 4-polig	E-Motor 400V / 50 Hz, 7.5 kW, 4-pole
011036	Keilriemen XPB 1800, Ex-geschützt	Keilriemen XPB 1800, Ex-geschützt
011038	Riemenscheibe ohne Spannbuchse, LW 450 E III /ES III - 50Hz, 2-polig	Pulley XPB w/o hub, LW 450 E III /ES III - 50Hz, 2-polig
011050	Riemenscheibe ohne Spannbuchse, LW 450 E III /ES III - 60Hz, 2-polig	Pulley XPB w/o hub, LW 450 E III /ES III - 60Hz, 2-polig
011051	Riemenscheibe ohne Spannbuchse, LW 300 E III /ES III - 60Hz, 4-polig	Pulley XPB w/o hub, LW 300 E III /ES III - 60Hz, 4-polig
011052	Riemenscheibe ohne Spannbuchse, LW 300 E III /ES III - 50Hz, 4-polig	Pulley XPB w/o hub, LW 300 E III /ES III - 50Hz, 4-polig
011181	Keilriemen XPB 1750	V-Belt XPB 1750

C

## DETAILANSICHT / DETAILED VIEW

### Motor / Motor

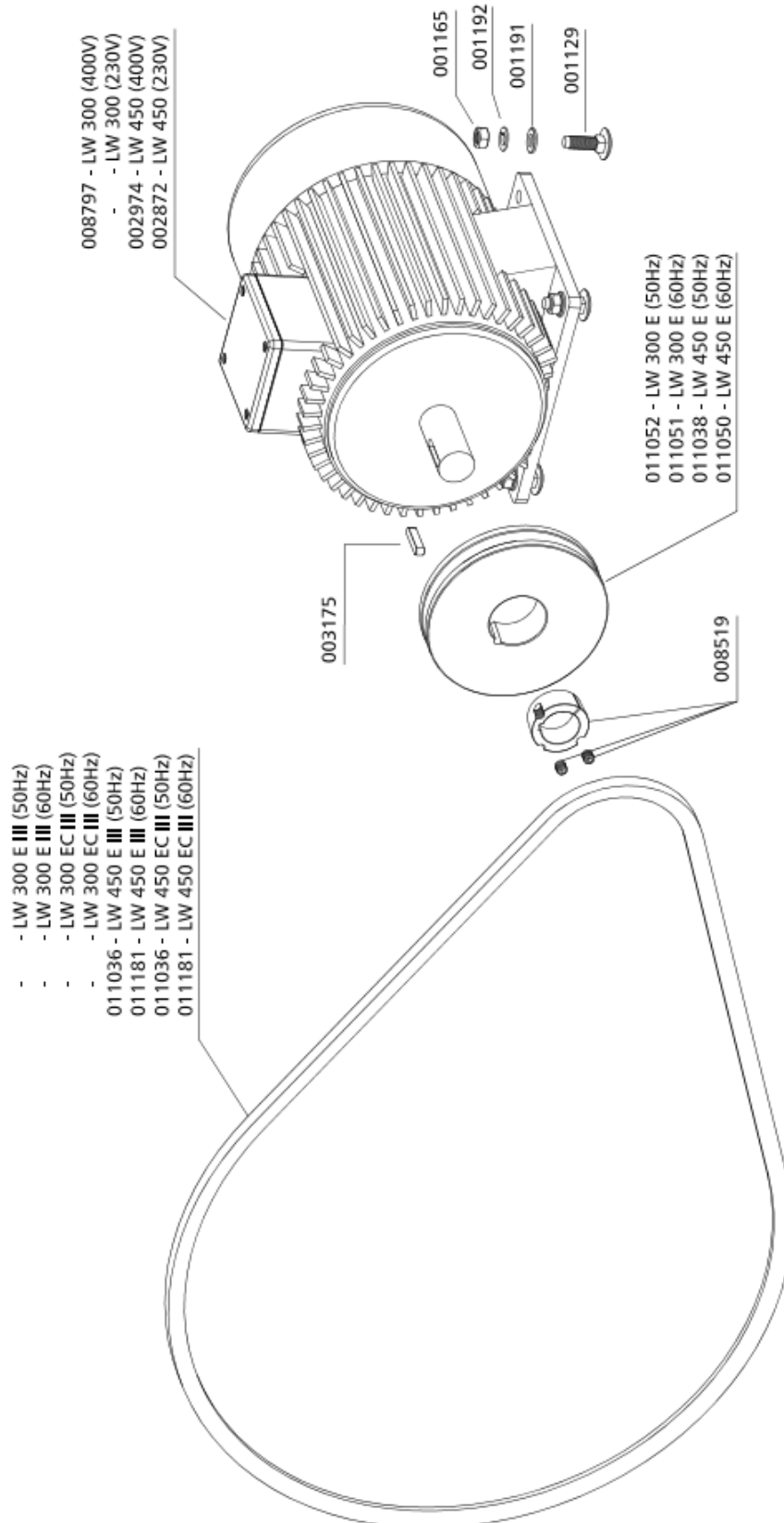

C





## ERSATZTEILLISTE / SPARE PART LIST

---

### Lüfterrad / Cooling Fan

Best.-Nr. / Order No.	Benennung	Description
000498	U-Scheibe A6	Washer A6
001030	Zylinderschraube, M6x16mm DIN912 8.8 ZN	Allen Bolt, M6x16mm DIN912 8.8 ZN
001133	6-kant Schraube	Hexagon Bolt M12x30
002335	Ventilatorflügelblatt, schwarz	Fan Blade, black, new version
005122	U-Scheibe Kurbelwelle	Washer, crank shaft
010168	Zahnscheibe A12	Lock Washer A12
011001	Schwungrad XPB, LW 450	Flywheel XPB, LW 450
011039	Zentrierring, Lüfterblätter, LW 450	Fixing Ring Fan Blades, LW 450

C

**DETAILANSICHT / DETAILED VIEW**

**Lüfterrad / Cooling Fan**

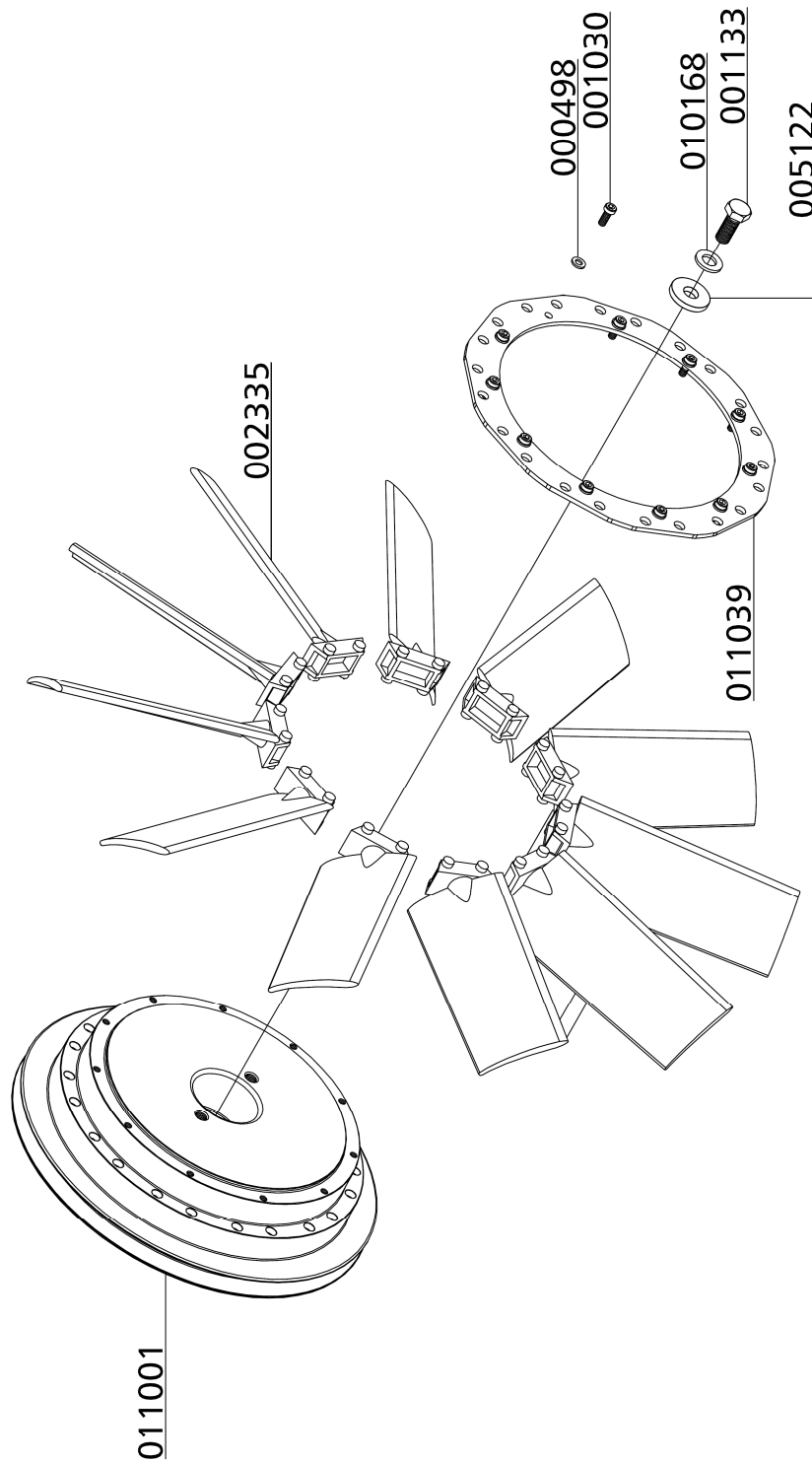



# ATTACHMENT

E

**Lenhardt & Wagner GmbH**

**An der Tuchbleiche 39  
D-68623 Lampertheim – Hüttenfeld**

www.lw-compressors.com



## Operating Instruction

### Safety valve

Typ:

**SiV2 BKZ 989 TÜV.SV.12-989.5.G.V.P CE 0091 AlMgSi1 F31 1100\* Lenhardt & Wagner**

**SiV BKZ TÜV.SV.14-1140.5.G.V.p CE 0091 AlMgSi1 F31 1100\* Lenhardt & Wagner**

<b>Set pressure:</b>	see mark (hand wheel on top of valve)
<b>Maximum outflow:</b>	Set pressure 100-159 bar: 750 l / min Set pressure 160-350 bar: 1.100 l / min
<b>Suitable media:</b>	Media-resistant, non-corrosive gases

The safety valve is used for protection of pressurized components, eg pipelines, pressure vessels, or the compressor itself.

The hand wheel on the top of the safety valve is marked with the adjusted set pressure.



- 1) *Identification of set pressure*
- 2) *Seal*
- 3) *Fixing screws<sup>1</sup>*
- 4) *Venting screw (hand wheel)*
- 5) *Identification serial number*
- 6) *Socket for safety valve*

Safety valve with socket

<sup>1</sup> und die Anforderungen des AD 2000 Merkblatts W7 erfüllen. The fixing screws M8 must be strength class 8.8 and meet the requirements of Merkblatt AD 2000 leaflet W7. Shaft length 70mm.

In order to prevent manipulation of the set pressure, all safety valves are factory fitted with a seal.

A safety valve on which the seal has been removed, must be returned to the manufacturer for repair / adjustment before further use.

In addition, the safety valve has a venting device (hand wheel).

When rotated clockwise, the safety valve and the filter housing of the final stage are completely vented.

During normal operation, the screw is unscrewed to the upper stop anticlockwise; an integrated safety ring prevents the screw from being removed.

---

If a safety valve blows off, the system must be switched off immediately and the cause of the error, investigated.

There are two possible reasons:

1. The safety valve is defective and blows off before the set pressure.

In this case the safety valve should be submitted immediately to the manufacturer for repair or replaced with a new one.

2. The safety valve opens properly, the problem is on the system.

A constant blowing of the safety valve is not permitted, the sealing seat of the valve can be damaged. The error on the system must be detected and repaired before further filling operations.

The safety valve may only be used if it is ensured that the maximum flowrate of the system does not exceed the blow-off rate of the safety valve.

The safety valve may only be used with the approved media.

Repair work on compressors must only be performed by trained personnel.

### **Dismantling of the safety valve**

Ensure that on the safety valve is no pressure.

Loosen and remove the two M8 fixing bolts with a 6 mm Allen key.

The safety valve can now be removed by turning and simultaneously pulling out of the socket.

### **Mounting**

1. Clean the safety valve socket.

2. Oil the insert pin of the safety valve including the O-ring with 1 to 2 drops of oil.

3. Press the safety valve pin complete into the socket.

4. Fasten the safety valve with the two 8 mm allen screws into the socket

(Tightening torque: 10 Nm)

5. Screw the venting screw (hand wheel) anticlockwise to its upper limit.

6. Start the System (Compressor), check installation for leaks and proper function.

**Manufacturer:** Lenhardt & Wagner GmbH  
An der Tuchbleiche 39  
D-68623 Lampertheim – Hüttenfeld

**Contact:** E-Mail: [service@lw-compressors.com](mailto:service@lw-compressors.com)  
Web: [www.lw-compressors.com](http://www.lw-compressors.com)  
Tel.: +49 (0) 6256 – 85880 0  
Fax: +49 (0) 6256 – 85880 14

---

**Note:**

*Only use safety valves which are in a technically perfect condition, for its intended purpose, safety and danger awareness, in compliance with the operating instructions!*  
*Faults which could affect safety must be rectified immediately!*

Notes:

- The safety valve must be installed directly on the protected pressure vessel and / or the plant.
  - The safety valve must be installed in an upright position.
  - The flow area of the port must be greater than the valve opening.
  - Protect valve against splashes
- 

Maintenance:

- In accordance with current Pressure Equipment Directives, the safety valve must be periodically checked for operation and reliability.
- Refill annually lubricating oil:  
Oil filling position:  
Hole on the spacer (see arrow, Figure 1)
- Oil level: Fill oil into the hole until oil comes out of the hole.

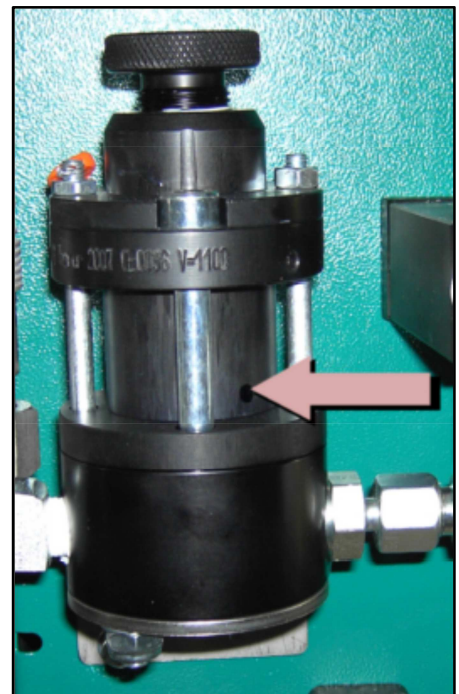

Figure 1: Position for oil refill

*To be used lubricating oil for the safety valve: L&W Article N°.: 008500 (content: 30 ml)*

---



INFORMATION ON THE  
SERVICE LIFE OF  
L&W HIGH PRESSURE HOSES





## CONTENTS

---

Testing hose lines	
Testing hose lines .....	3
Testing after assembly and before commissioning .....	3
Recurring test .....	4
Procedure for hose lines found to be "defective" .....	4
Test intervals.....	4
Persons qualified to test hose lines.....	5
 Maintenance	
Replacing hose lines .....	6
Immediate replacement of hose lines .....	6
 Service life	
Service life of L&W high pressure hoses.....	7
 Storage	
Storing hose lines .....	8
 Annex	
Scope of testing, test criteria .....	10 - 11





## TESTING HOSE LINES

---

### **Testing hose lines**

An essential factor in ensuring operational safety when handling L&W compressors is the proper testing of the hose lines used.

Tests are necessary:

- After assembly and before commissioning the hose line.
- After accidents, changes (modifications) to the compressor system, longer periods of non-use and damage due to, for example, collisions or natural phenomena (extraordinary test).
- After carrying out repair work on the compressor system that could compromise safety.
- Recurrently at fixed, regular intervals.

The proprietor must determine the type, scope and deadlines for the tests according to his or her individual operating conditions and on the basis of a risk assessment. **The specifications and recommendations of the manufacturer must be observed.** The specifications made regarding type, scope and deadlines (as well as the replacement intervals) must be documented in writing as occupational health and safety measures.

The results of the tests must also be recorded, e.g. together with the test report of the machine, and kept at least until the next test.

The above-mentioned tests may only be carried out by persons who are qualified to do so and who are authorized by the company (employer).

### **Testing after assembly and before commissioning**

In the test after assembly and before commissioning, factors relating to assembly or factors that can only be evaluated on the fully assembled machine must be assessed.

The assembled hose lines must also be assessed.

Some test points can already be assessed during a visual inspection when the machine is switched off.

An overview of the recommended scope of testing for a visual inspection of hose lines is given in the appendix.

Further test points included in the test of hose lines before commissioning, require a functional test with the machine running.

A recommendation for the scope of testing is given in the appendix.



## TESTING HOSE LINES

---

### **Recurring test**

Since hose lines are subject to influences that cause damage during operation and can lead to dangerous situations, they must be tested recurrently at fixed intervals. The aim of recurring tests is to detect and repair damage in good time.

The objective is to ensure that the system remains in a safe condition.

### **Procedure for hose lines found to be "defective"**

If defects are found during the testing of the hose line that impair the safe condition of the work equipment, these must be rectified immediately. If this is not possible, suitable measures must be taken to ensure that the machine cannot be used further before it is repaired. Defective hose lines must be replaced before the machine can be used further.

It is not permitted to repair or reassemble damaged hose lines with old, previously used parts!

If several hose lines are replaced at the same time, precautions must be taken to prevent mix-ups of the connections or the installation points.

### **Test intervals**

Deadlines for the recurring tests of the hose lines should already be set before commissioning.

Otherwise, there is a risk that work equipment will continue to be used or operated for too long without being tested.

The intervals between the recurring tests must be selected in such a way that deviations from the safe operating condition of work equipment can be detected and eliminated in good time.

The intervals for recurring tests specified here are guidelines and based on experience. Shorter test intervals may have to be specified on the basis of the risk assessment; special operating conditions; or according to the manufacturer's specific instructions in the machine operating manual. Longer test intervals may also be specified, provided that this is justifiable and tenable from a safety point of view. The determination of the test intervals should be documented.

<b>Type of test</b>	<b>Recommended test intervals</b>
Visual inspection	Before commissioning the system
Functional test	Annually with previous visual inspection

### **Persons qualified to test hose lines**

A qualified person is a person who, through his or her professional training, professional experience and recent professional activity, has the necessary specialist knowledge required for testing work equipment - in this case for testing hose lines.

These requirements are defined in the Technical Rules for Industrial Safety TRBS 1203

"Qualified persons - general requirements" fulfilled if:

- the qualified person has completed a professional training that enables his or her professional knowledge to be determined in a comprehensible manner, i.e. based on professional qualifications or comparable evidence. For the testing of hose lines, the person concerned must have completed a technical professional training or another technical qualification sufficient for the intended testing tasks. The object is to guarantee that the tests will be carried out properly.
- proof of practical use at work of the equipment to be tested as well as the associated professional experience is provided. The qualified person must be sufficiently familiar with the conditions that demand the performance of tests, such as the result of the risk assessment or observations during the working day.
- there is proof of recent professional activity in the area of the upcoming tests and appropriate further training. The qualified person must also have gained experience with regard to the tests to be performed or comparable tests. He or she must also have knowledge of the state of the art with regard to the work equipment or components to be tested as well as the hazards to be considered. This also includes knowledge of the relevant technical regulations and the updating of this knowledge, e.g. through participation in training courses/instruction.

The qualified person is not subject to any technical instruction during the course of his or her testing activity and must not be disadvantaged because of this.

Experts who have carried out tests on the hose lines up to now and who meet the three criteria mentioned above and who have familiarized themselves with the contents of the German Ordinance on Industrial Safety and Health and the changes associated with it are also considered qualified persons to whom the tests can continue to be assigned.

See also:

- ⇒ § 2 para. 7 of the German Ordinance on Industrial Safety and Health,
- ⇒ Technical Rules for Operational Safety TRBS 1203.



### **Replacing hose lines**

As a general rule, even when stored properly and subjected to permissible stress during use, all hose lines are subject to natural aging, which changes the material and composite properties and reduces the performance of the hose lines.

This limits the service life of a hose line and the operator must ensure that hose lines are replaced at appropriate intervals.

### **Immediate replacement of hose lines**

Hose lines must be replaced immediately in the event of the following defects:

- External visible damage to the hose line or fittings.
- Internal damage to the tube or the reinforcement.
- Leakage from the hose line or the fittings.
- Deformation of the hose line or the fittings.



## SERVICE LIFE

---

### **Service life of L&W high pressure hoses**

When determining the service life or the replacement interval of the individual hose lines, the concrete specifications and recommendations of the hose line or machine manufacturer must be observed. Furthermore, empirical values resulting from previous tests done under the prevailing operating conditions on site are also relevant.

Guideline values for recommended replacement intervals of hose lines which have proven themselves in practice are summarized below.

<b>Hose line requirements</b>	<b>Recommended replacement intervals</b>
Standard requirements	6 years (Service life including a maximum of 2 years storage time)
Increased requirements, e.g. due to - increased operating time, e.g. multi-shift operation, or short machine or pressure pulse cycle times - strong external and internal influences (due to the medium), which greatly reduce the service life of the hose line	2 years (service life)

The guideline given above for a replacement interval of six years for hose lines meeting normal requirements includes a maximum storage period of two years. The guideline value of two years for hose lines meeting increased requirements represents the maximum permissible service life.

A prolongation of the guideline values given above for replacement intervals is possible if

- appropriate test values and empirical values are available from the operator of the machine which permit safe continued use beyond the recommended maximum service period,
- a hazard or risk assessment, documented in writing, has been carried out by the operator, which also takes into account protective measures in the event of failure of hose lines, and
- tests for safe working conditions are carried out by qualified persons at appropriately set, if necessary reduced, intervals.

It must be ensured that the prolongation of the replacement intervals does not result in a dangerous situation that could injure employees or other persons.

If hose lines fail during operation or if damage or defects are frequently detected during the recurring tests, then, in addition to investigating the causes, the test and replacement intervals must be shortened.



## STORAGE

---

### **Storing hose lines**

When storing hose lines, storage conditions must be aimed at minimizing the natural aging that occurs over time and the associated change in material and composite properties.

For this purpose, the following information must be provided:

- Store in a cool, dry and low-dust place.  
Low-dust storage can be achieved, for example, by wrapping the hoses in plastic film.
- Avoid direct sun or UV radiation.
- Shield from nearby heat sources.
- Avoid storage temperatures below -10 °C for elastomers.
- Do not use ozone-generating light fittings or electrical devices that may produce sparks in the immediate vicinity.  
(Ozone-generating light fittings are, for example, fluorescent light sources, mercury vapor lamps).

The most favorable storage conditions are temperatures between +15 °C and +25 °C, as well as a relative humidity below 65 %.

During storage, hose lines must not come into contact with substances that could cause damage, e.g. acids, alkalis, solvents. Penetration of ozone or other harmful air constituents can be prevented by sealing the ends or by wrapping the hoses in plastic film. They must be stored flat and free of tension.

The storage period for hose lines should not exceed two years.



# ANNEX

**Recommended scope of testing "visual inspection" (before initial commissioning or recommissioning)**

- Is all user information required for safe operation of the system available (e.g. flow chart, operating instructions)?
- Do the hose lines comply with the flow chart or parts list?
- Are there protective measures in place, such as pressure relief valves, for cases of unusually high pressure pulses or pressure amplifications?
- Are the hose lines marked with the name or abbreviation of the manufacturer, maximum permissible operating pressure, nominal diameter, quarter/year of manufacture?
- Are the hose lines installed in such a way that, in accordance with DIN 20 066
  - the natural position does not hinder movement?
  - turning or twisting of the hose is prevented, likewise tensile load caused by a line that is too short and a bending radii that is too small?
  - the hose is routed via a kink protector (if necessary on the connecting element)?
  - sufficient clearance prevents external mechanical influences or abrasion on the edges?
  - hose bridges prevent damage being caused by driving over the hose line?
  - hose guides (such as hose saddles and sufficiently wide hose brackets) protect loosely laid hose lines and
  - a heat shield protects against high temperature exposure?
- Are suitable protective measures, such as fixtures, safety gear or shielding provided for hose lines that, in the event of failure, pose a risk of whipping?  
A risk is to be assumed if persons are generally present in the immediate vicinity of the hose lines, for example.
- Do the hose lines of newly commissioned or re-commissioned machines already show signs of damage?
- Are the installed hose lines still within the storage/use period recommended by the relevant manufacturer?
- Are the hose lines free of paint?
- Are the hose lines free of chafe marks?
- Does the operating manual contain information on test intervals? If so, what?

Note:

The installed hose lines should not be made from used hoses or used press fittings that have already been in use as part of a hose assembly!





## ANNEX SCOPE OF TESTING; TEST CRITERIA

---

### **Recommended scope of testing "Functional test" (before initial or recommissioning)**

Note:

Visual inspection must be carried out before the functional test

- All parts of the system must be tested at least at the maximum working pressure that could be achieved taking into account all intended applications:
  - Are the hose lines and connecting elements free of leakage?
  - Have all hose lines withstood the pressure?

Note:

The installed hose lines should not be made from used hoses or used press fittings which have already been in use as part of a hose assembly!