



CHAPTER OVERVIEW

Operating Instructions	A
ECC - Electronic Compressor Control (if equipped)	B
Spare Parts Lists	C
Options (if equipped)	D
Attachment	E

Manufacturer in terms of 97/23/EC

The full name and address of the manufacturer is:

Lenhardt & Wagner GmbH

An der Tuchbleiche 39
68623 Hüttenfeld / Germany

Phone: +49 (0) 62 56 - 85 88 0 - 0

Fax: +49 (0) 62 56 - 85 88 0 - 14

E-Mail: service@lw-compressors.com

Internet: www.lw-compressors.com





SERVICE INFORMATION / WARRANTY

Compressor information

Type designation

Serial number

Date of construction

Purchase information

Purchase date

First commissioned on

Warranty period

Dealer's stamp

Warranty

L&W will uphold warranty claims made during a period of 12 months from the invoice date.

If the compressor was purchased from an official L&W dealer, the date on the dealer's invoice is valid. Warranty claims can only be made on presentation of the original invoice.

Should verifiably defective parts have been delivered, we will decide to either replace the parts or repair them. The resulting transport and assembly costs will be invoiced.

No reduction of the purchase price or changes to the contract can be made. The parts for which a claim is being made should be kept safe by the purchaser and, when requested, sent to us at their cost. Replaced parts become the property of L&W. If maintenance work is carried out without our knowledge or permission by the purchaser or a third party, we are absolved from any liability for warranty claims. As a matter of principle, warranty claims can only be made by the initial purchaser.

Operating Instructions

Breathing Air Compressor

LW 450 E Compact

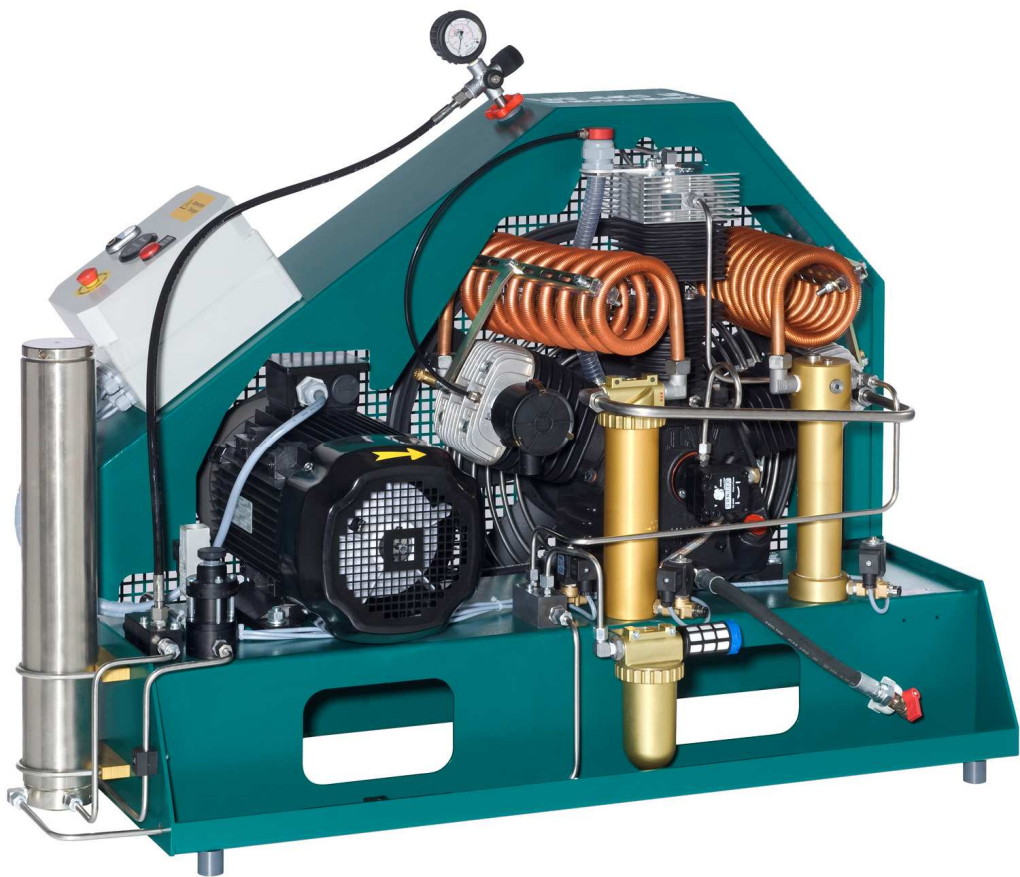



TABLE OF CONTENTS

General Information and Technical Data

General Information / Description of Warning Symbols	4
Scope of Delivery	5
Technical Data	6
Unit Assembly	7
Switchboard	8
Flow chart	9

Safety Precautions

Intended Use / Operators	11
Safety instructions on the unit	12
General Safety Precautions	13
Unit customised safety notices	14
Maintenance instructions	15
Transportation instructions / Safety regulations	16

Installation

Installation in closed rooms	18
Dimensions	19
Minimum distances	20
Ventilation	21
Electrical Installation	22 - 23

Operation

Important operation instructions	25
First commissioning	26 - 28
Daily commissioning	29
Filling procedure	30
Switch off the compressor	31

Remedying faults	32 - 36
-------------------------------	---------

Maintenance and Service

Service, Repair and Maintenance	38
Maintenance Lists / Maintenance Intervals	39 - 42
Service Kits	43
Check V-belt tension / Tension V-belt	44
Compressor lubrication / Check oil level	45
Oil change	46
Oil sieve change	47
Manual condensation dump system	48

A



TABLE OF CONTENTS

Maintenance and Service

Oil / water separator 1st stage - maintenance	49
Oil / water separators 2nd stage - maintenance	50
Filter housing / Filter cartridge	51
Filter cartridge change.....	52
Filter housing - Maintenance	53
Inlet filters / Inlet filter cartridge change	54
Cylinder heads and valves	55
Replace inlet and outlet valves 1st and 2nd stage	56 - 57
Replacement inlet and outlet valves 3rd stage	58
Safety valves	59
Pressure maintaining / non return valve	60
Pressure gas vessel test	61
Maintenance records	63 - 67

Storage

Conservation / storage of the compressor	68
De-conservation, commissioning	68
Transportation instructions / Disposal	69

A



GENERAL INFORMATION

General Information

We strongly recommend reading this manual thoroughly prior to operation and follow all the safety precautions precisely. Damage resulting from any deviation from these instructions is excluded from warranty and liability for this product. Carry out other commissioning steps only if you have fully understood the following contents.

Before commissioning and using the unit, carry out all the essential preliminary work and measures concerning legal regulations and safety. These are described on the following pages of this operation manual.

A

Description of marks and warning signs

The following warning signs are used in this document to identify the corresponding warning notes which require particular attention by the user. The warning signs are defined as follows:



Caution

Indicates an imminently hazardous situation which, if not avoided, could result in serious injury, physical injury or death.



Warning

Indicates a potentially hazardous situation which, if not avoided, could result in physical injury or damage to the product or environment.



Note

Indicates additional information on how to use the unit.



DESCRIPTION

Scope of Delivery

Compressors are provided in different equipped versions.

A

Versions

Filling pressure versions:

- PN 225 bar
- PN 330 bar
- PN 225 / 330 bar

Specifications

- Painted steel frame and V-belt guard (RAL 6026)
- Hour counter
- Start/ Stop and emergency stop switch
- Manual condensate drain
- 1 filling hose c/w filling valve
- Motor protection switch
- Pressure maintaining and non-return valve
- All pistons c/w steel piston rings
- Low pressure oil pump and filter
- Oil / water separators after each stage
- Safety valves after each stage
- 3 concentric suction/pressure valves

Options

- Automatic dump system
- Automatic stop at final pressure
- Auto start system
- Up to 3 extra filling hoses
- 200 and 300 bar parallel filling operation
- Oil pressure gauge and intermediate pressure gauge
- Oil pressure monitoring c/w auto shut down
- Cylinder head temperature monitoring with auto shut down
- Puracon filter monitoring
- Direction of rotation monitoring
- Power cable and plug

DESCRIPTION

Technical Data

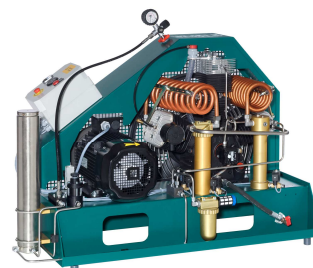

A

Technical Data	LW 450 E Compact
Capacity [l/min]:	450
Max. Operating Pressure [bar]:	350
RPM [min ⁻¹]:	1,100
Number of Pressure Stages:	3
Cylinder Bore 1st Stage [mm]:	Ø 95
Cylinder Bore 2nd Stage [mm]:	Ø 42
Cylinder Bore 3rd Stage [mm]:	Ø 18
Medium:	Compressed Air / Breathing Air
Intake Pressure:	atmospheric
Oil Pressure (at operating temperature) [bar]:	+1.5 (-0,2)
Oil Capacity [l]:	2.2
Intake Temperature [°C]:	0 < +45
Ambient Temperature [°C]:	+5 < +45
Cooling Air Volume [m ³ /h]:	> 3,300
Voltage:	400 V / 3 phase / 50 Hz
Protection Class Drive Motor:	IP 54
Drive Power [kW]:	11
RPM Motor [min ⁻¹]:	2,890
Start:	Star/Delta
Noise level [dB(A)]:	83 from a distance of 1 m
Dimensions L x W x H [mm]:	1300 x 600 x 900
Weight [kg]:	ca. 235
Content Volume Filter housing [l]:	1.7

DESCRIPTION

Unit Assembly

A

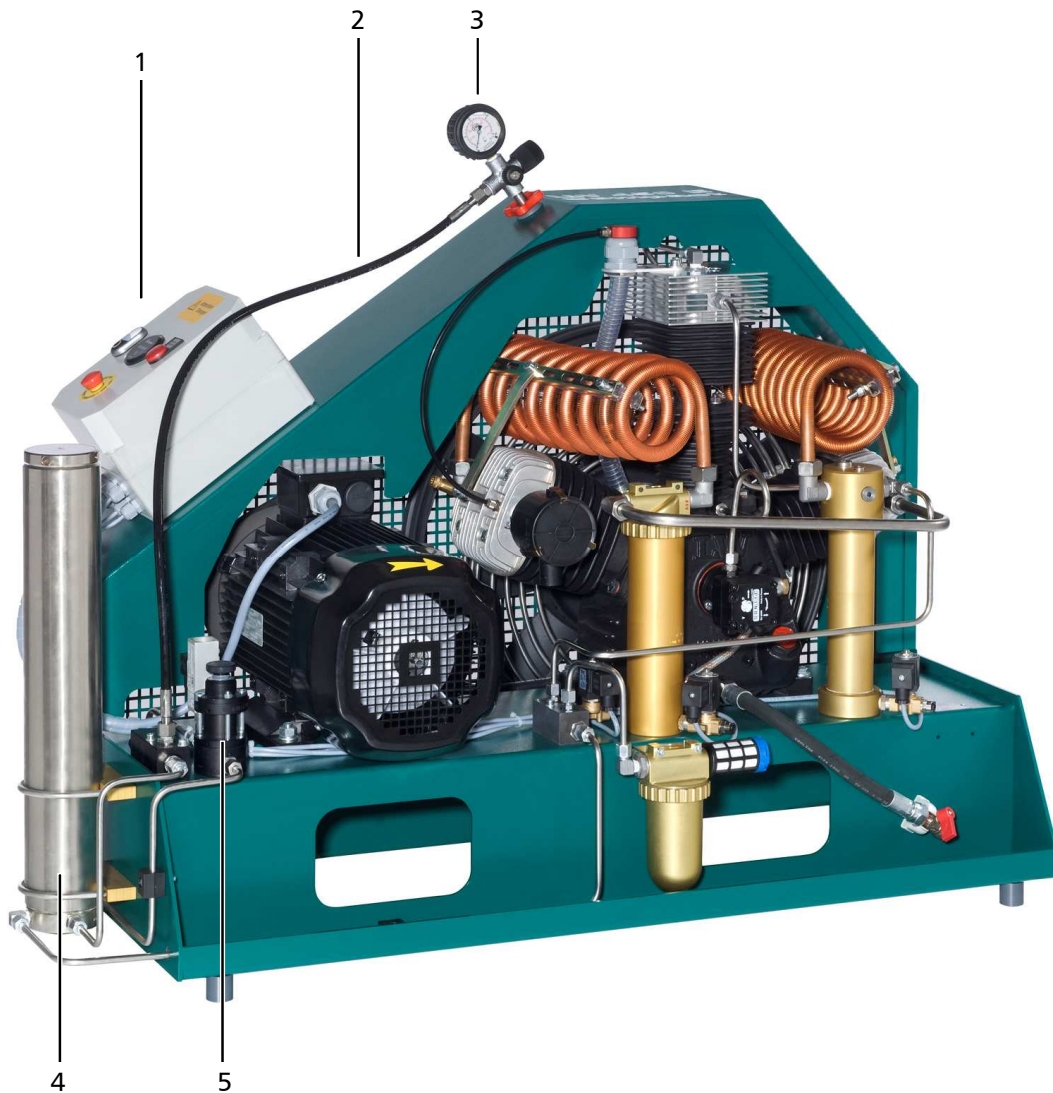

No.	Designation
1	Switch box
2	Filling hose
3	Filling valve with pressure gauge
4	Filter housing 1.7 litres
5	Final pressure safety valve

DESCRIPTION

Switchboard

A

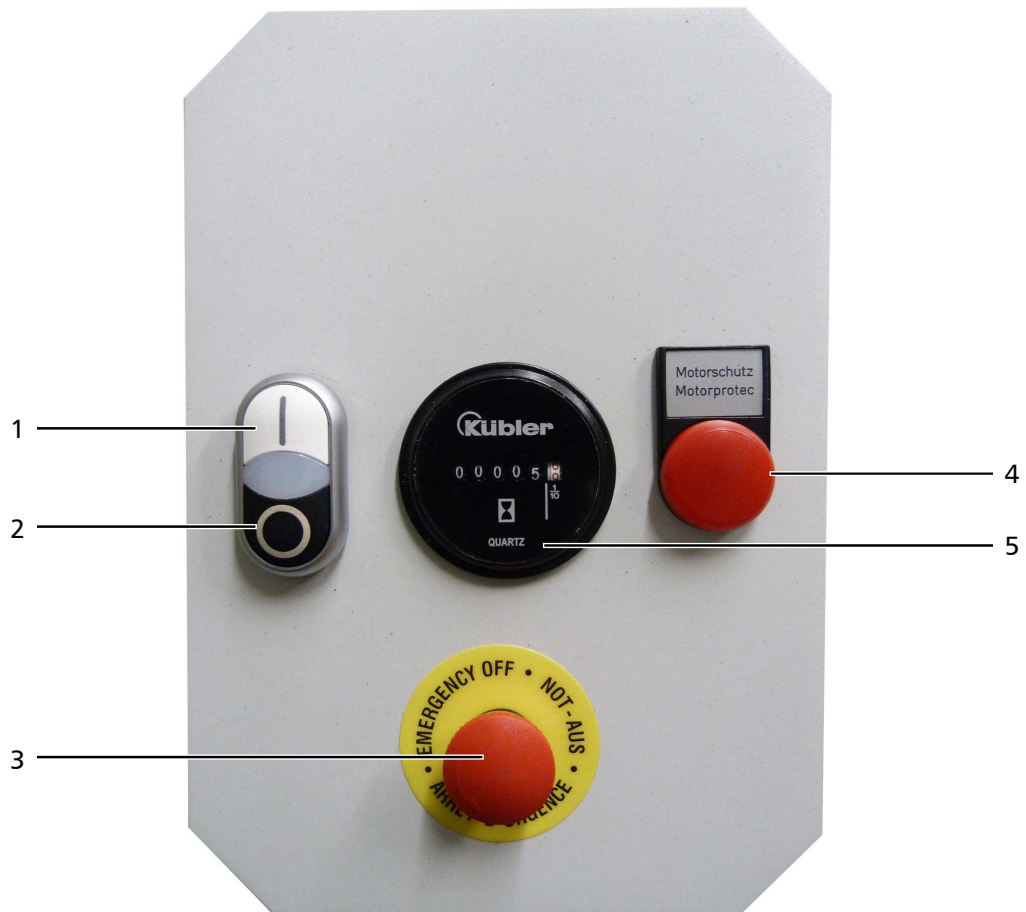

No.	Designation
1	ON button
2	OFF button
3	Emergency shut-off switch
4	Motor protection warning light
5	Hour counter

DESCRIPTION

Flow chart

A

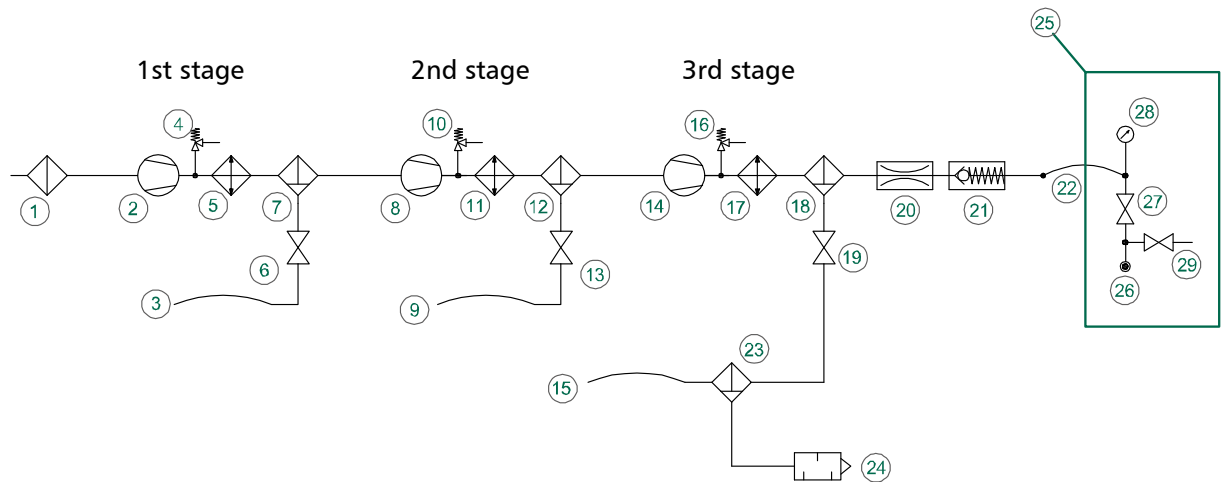

- | | |
|---|--|
| 1. Ansaugfilter / Intake Filter | 16. Sicherheitsventil 3. Stufe / Safety Valve 3rd Stage |
| 2. 1. Verdichterstufe / 1st Pressure Stage | 17. Wärmetauscher / Heat Exchanger |
| 3. Kondensat-Ablassschlauch / Condensate Drain Hose | 18. Öl- / Wasserabscheider / Oil- / Water Separator |
| 4. Sicherheitsventil 1. Stufe / Safety Valve 1st Stage | 19. Kondensat-Ablassventil / Condensate Release Valve |
| 5. Wärmetauscher / Heat Exchanger | 20. Druckhalteventil / Pressure Maintaining Valve |
| 6. Kondensat-Ablassventil / Condensate Release Valve | 21. Rückschlagventil / Non-Return Valve |
| 7. Öl- / Wasserabscheider / Oil- / Water Separator | 22. Hochdruckschläuche / HP-Hose |
| 8. 2. Verdichterstufe / 2nd Pressure Stage | 23. Öl- / Wasserabscheider / Oil- / Water Separator |
| 9. Kondensat-Ablassschlauch / Condensate Drain Hose | 24. Schalldämpfer / Silencer |
| 10. Sicherheitsventil 2. Stufe / Safety Valve 2nd Stage | 25. Baueinheit Füllventil / Filling Valve Unit |
| 11. Wärmetauscher / Heat Exchanger | 26. Flaschenanschlussstutzen / Tank Connector (DIN, CGA or INT Yoke) |
| 12. Öl- / Wasserabscheider / Oil- / Water Separator | 27. Füllventil / Filling Valve |
| 13. Kondensat-Ablassventil / Condensate Release Valve | 28. Fülldruckmanometer / Pressure Gauge |
| 14. 3. Verdichterstufe / 3rd Pressure Stage | 29. Entlüftungsventil / Vent Valve |
| 15. Kondensat-Ablassschlauch / Condensate Drain Hose | |



A

SAFETY PRECAUTIONS



SAFETY PRECAUTIONS

A

Intended Use

Only use the unit in perfect condition for its intended purpose, safety and intended use and observe the operating instructions! In particular disorders that may affect safety have to be eliminated immediately!

Use the unit exclusively for the determined medium (see "Technical Data"). Any other use that is not specified is not authorized. The manufacturer/supplier shall not be liable for any damages resulting from such use. Such risk lies entirely with the user. Authorization for use is also under the condition that the instruction manual is complied with and inspection and maintenance requirements are enforced.

No change and modification to the unit can be made without the written agreement of the manufacturer. The manufacturer is not liable for damage to persons or property resulting from unauthorised modifications.

Operators

Target groups in these instructions;

Operators

Operators are persons who are authorized and briefed for the use of the compressor.

Qualified personnel

Qualified personnel are persons who are entitled to repair, service, modify and maintain the system.



Warning

Only trained personnel are permitted to work on the unit!



Warning

Work on the electrical equipment on / with the machine / unit may only be carried out by qualified electricians.

SAFETY PRECAUTIONS

Safety instructions on the unit

Importance of notes and warning signs that are affixed to the compressor according to the application or its equipment.

A



Warning
High voltage!

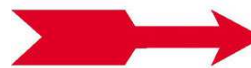

Note
Ensure correct direction of rotation!



SAFETY PRECAUTIONS

General Safety Precautions

- Read the Operating Instructions of this product carefully prior to use.
- Strictly follow the instructions. The user must fully understand and strictly observe the instructions. Use the product only for the purposes specified in the intended use section of this document.
- Do not dispose the operating instructions. Ensure that they are retained and appropriately used by the product user.
- Only trained and competent personnel are permitted to use this product.
- Comply with all local and national rules and regulations associated with this product.
- Only trained and competent personnel are permitted to inspect, repair and service the product.
- Only authentic L&W parts and accessories may be used for maintenance work. Otherwise, the proper functioning of the product may be impaired.
- Do not use faulty or incomplete products. Do not modify the product.
- Inform L&W in the event of any product or component fault or failure.
- The quality of the air supply must meet EN 12021 specifications for breathing air.
- Do not use the product in areas prone to explosion or in the presence of flammable gases. The product is not designed for these applications. An explosion might be the result if certain conditions apply.

A



SAFETY PRECAUTIONS

Unit customised safety notices

Organisational measures

- In addition to the instruction manual, observe and comply with universally valid legal and other obligatory regulations regarding accident prevention and environment protection.
- In addition to the instruction manual, provide supplementary instructions for supervision and monitoring duties taking into consideration exceptional factors e.g. with regard to organisation of work, production, personnel employed.
- Supervise personnel's work in accordance with the instruction manual, taking into account safety and danger factors.
- Observe all safety and danger notices on the compressor and check readability and completeness.

Safety instructions operation

- Take measures to ensure that the machine is only taken into operation under safe and functional conditions. Only operate the compressor if all protective and safety equipment, e.g. detachable protective equipment, are provided and in good working order.
- Check the compressor at least once per day for obvious damage and defects. Inform the responsible department / person immediately if anything is not as it should be (including operation performance). Shut down the machine immediately if necessary and lock it.
- In case of malfunction, stop the compressor immediately and lock it. Repair malfunctions immediately.
- If there is a failure in the electric energy supply, shut the machine / unit down immediately.
- Ensure safe and environmentally friendly disposal of consumables and old parts.
- The stipulated hearing protectors must be worn.
- Soundproofing equipment on the compressor has to be activated in safety function during operation.
- When handling with fats, oils and other chemical agents, observe the note for the product-related safety.

A



SAFETY PRECAUTIONS

Maintenance instructions

- Hoses have to be checked by the operator (pressure and visual inspection) at reasonable intervals, even if no safety-related defects have been detected.
- Immediately repair any damage. Escaping compressed air can cause injury.
- Depressurise system and pressure lines before beginning repair work.
- Pressurised air lines must be laid and mounted by qualified personnel. Connections must not be mixed up. Fittings, length and quality of the piping must correspond to requirements.
- Adjustment, maintenance and inspection activities and keep appointments, including information on replacement parts / equipment, prescribed in the operating instructions have to be respected.
- If the machine / equipment is completely off during maintenance and repair work, it must be protected against unexpected restart. Turn off main control device and remove the key and/or display a warning sign on the main switch.
- The machine and especially the connections and fittings should be cleaned from oil, fuel and maintenance products at the beginning of the maintenance / repair. Do not use aggressive cleaning agents. Use fibre-free cleaning cloths.
- Switch off compressor and clean with a slightly damp cloth. Remove dirt from cooling pipes by using a brush.
- After cleaning, examine all pipes for leaks, loose connections, chafing and damage. Immediately eliminate any faults.
- Always retighten any screw connections loosened for maintenance or repair work.
- If it is necessary to remove safety devices for maintenance and repair work, these must be replaced and checked immediately after completion of the maintenance or repair work.
- The electrical equipment of the compressor must be regularly checked. Defects, such as loose screw connections or burnt wires, must be immediately rectified by electrically skilled personnel.
- Only personnel with particular knowledge and experience with pneumatics may carry out work on pneumatic equipment.
- Only personnel with particular knowledge and experience in gas equipment may carry out work on gas equipment.

A



SAFETY PRECAUTIONS

Transportation instructions

- Parts which need to be dismantled for transport purposes must be carefully replaced and secured before taking into operation.
- The transport may only be carried out by trained personnel.
- For transportation, only use lifting devices and equipment with sufficient lifting power.
- Do not stand or work under suspended loads.
- Also separate from minor relocation machinery / system of any external energy supply. Before recommissioning, reconnect the machine to the mains according to regulations.
- When recommissioning, proceed according to the operating instructions..

Safety regulations

- Inspections according to legal and local obligatory regulations regarding accident prevention are carried out by the manufacturer or by authorised expert personnel. No guarantees whatsoever are valid for damage caused or favoured by the non-consideration of these directions for use.

A



A

INSTALLATION

INSTALLATION

Installation in closed rooms



Danger

No operation in explosion-hazard areas.

The unit is not approved for operation in areas prone to explosion.

A

For installation in closed rooms, observe the following:

- Install the unit horizontally and level. The floor must be vibration-free and capable of taking the load of the system weight.
- The compressor room must be clean, dry, dust free and as cool as possible. Avoid direct exposure to sunlight. If possible, install unit in such a manner that the compressor fan can intake fresh air from outside. Ensure adequate ventilation and exhaust air opening.
- When locating the compressor in rooms of less than 30 m³ space where natural ventilation is not ensured or other systems having high radiation are operating in the same room, measures must be taken to provide artificial ventilation.
- Intake air must be free from noxious gas e.g. smoke, solvent vapours, exhaust fumes etc.
- Observe the specified operating temperature (see "Technical Data")!

INSTALLATION

Dimensions

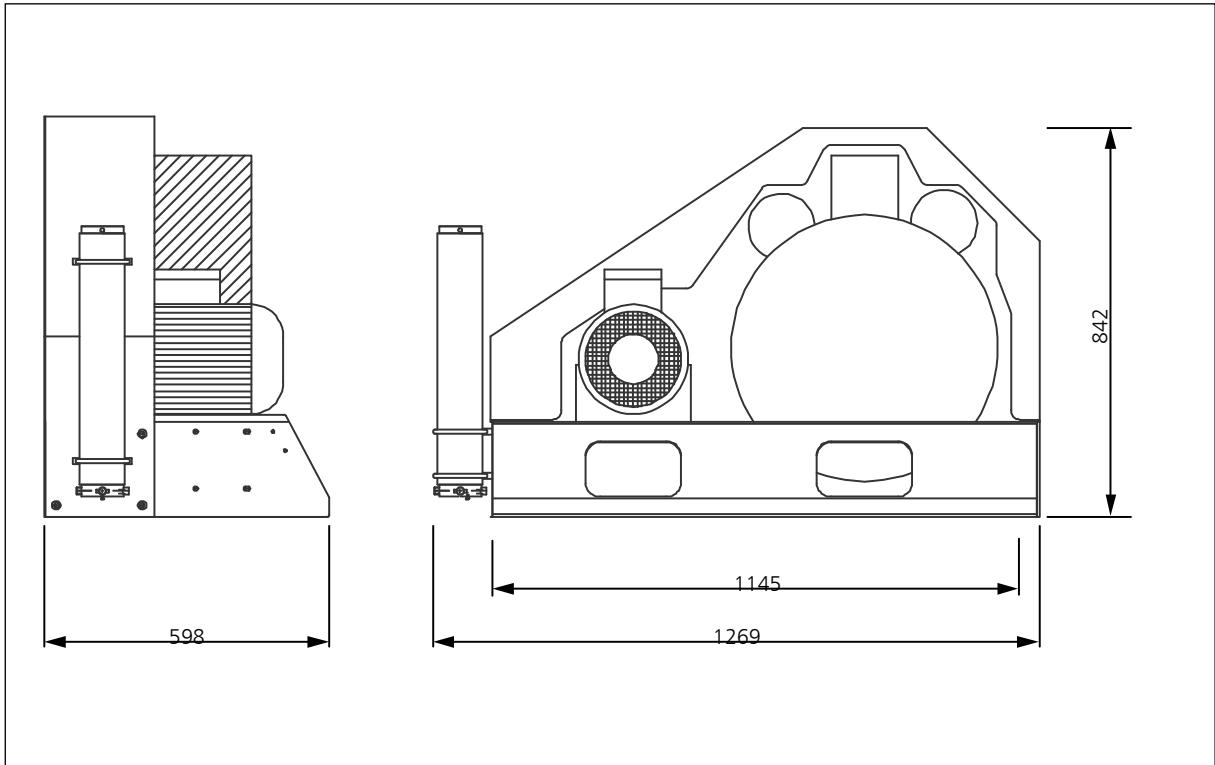

Fig. Dimensions

A

INSTALLATION

Minimum distances



Note

Minimum distances must be adhered!

- Make sure that the compressor always has a sufficient amount of fresh air available.
- To prevent serious damage, ensure that the cooling air flow can flow freely.
- The following minimum distances must be adhered:
Front side min. 1500 mm, sides min. 500 mm, rear side min. 500 mm.
Avoid anything in this area which can restrict the cooling air flow.

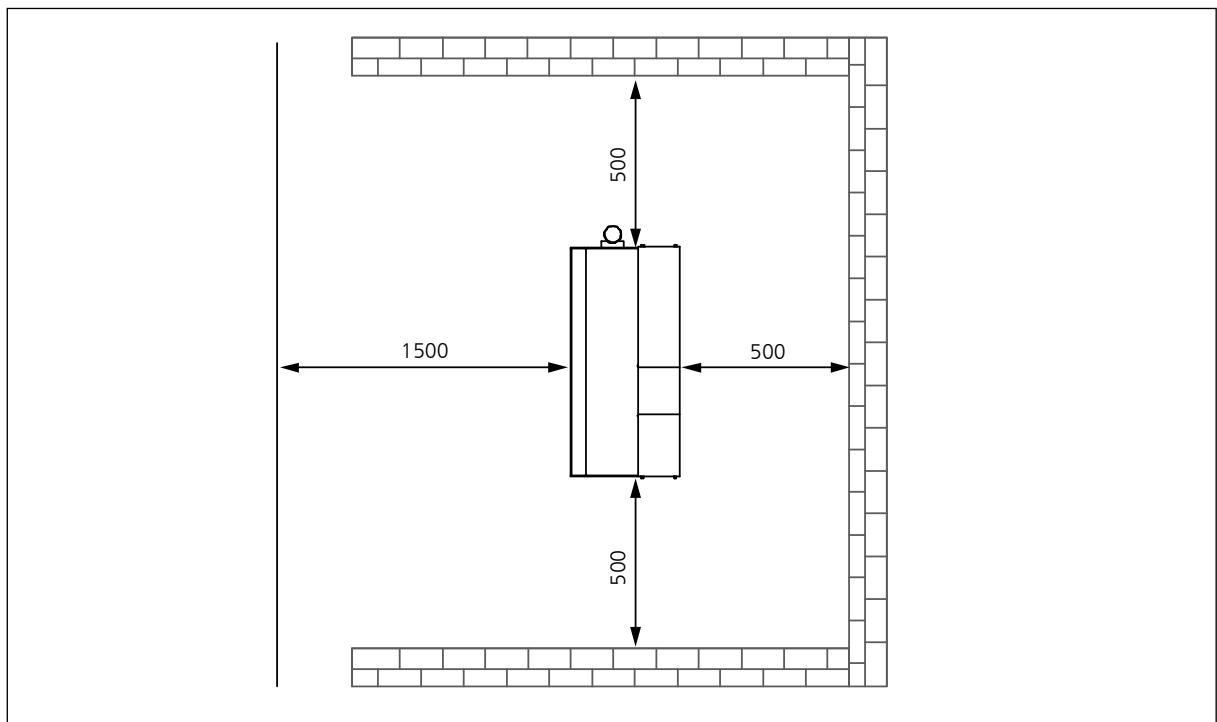

Fig. Minimum distances

INSTALLATION

Ventilation

- Make sure that the compressor always has a sufficient amount of fresh air available for cooling.
- To prevent serious damage, ensure that the cooling air flow can flow freely.
- The necessary cooling air flow can be calculated by using the following formula:
 $300 \times \text{drive power [kW]} = \text{required cooling air flow [m}^3/\text{h]}$
 Example 11kW motor: $300 \times 11\text{kW} = 3300 \text{ m}^3/\text{h} = \text{required cooling air flow.}$
- The fan capacity for fresh air and warm air must meet at least the required cooling air flow.
 The fans must have the same capacity.

A

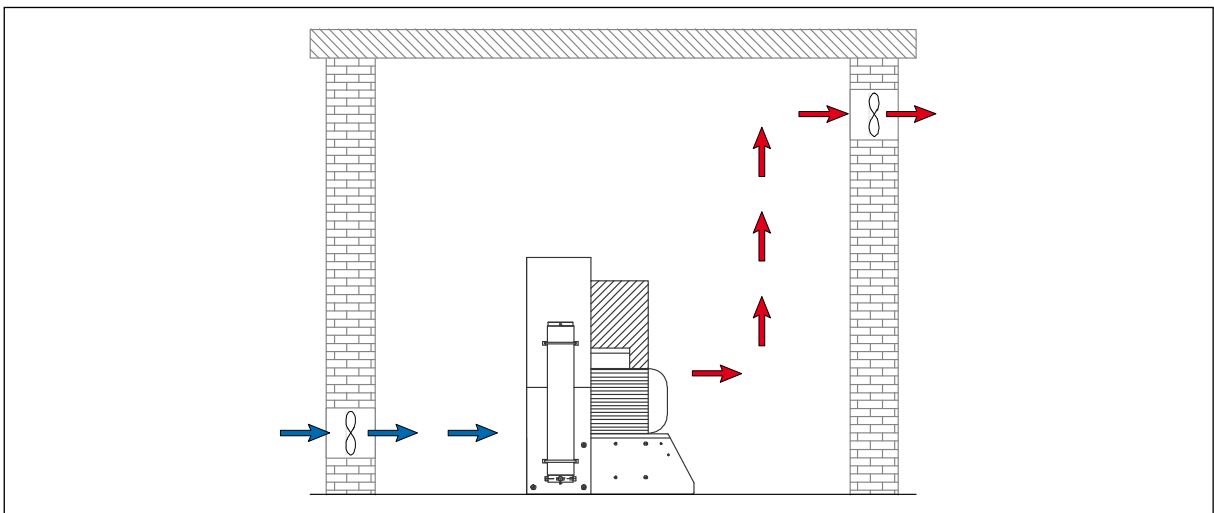

Fig. Ventilation through facade

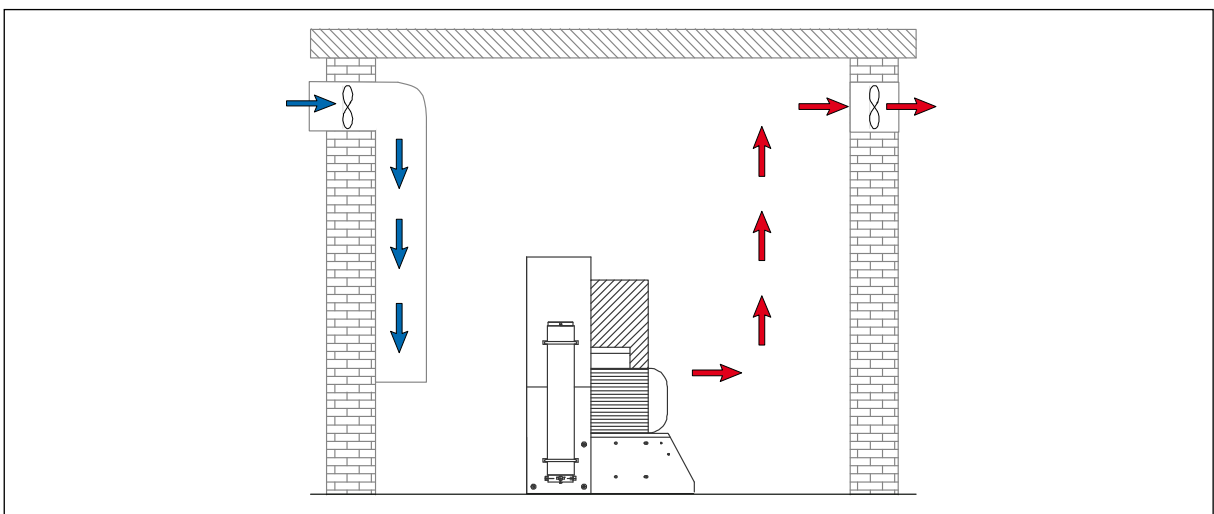

Fig. Ventilation via ventilation stack

INSTALLATION

Electrical Installation



Warning

Work on the electrical equipment on / with the machine / unit may only be carried out by qualified electricians.

For installation of electrical equipment, observe the following:

- If control devices are delivered by the factory, refer to the appropriate wiring diagram.
- Ensure correct installation of protective conductors.
- Check conformity of motor and control device tension and frequency with those of the electric network (see name plate on the compressor).
- The fusing should be done in accordance with the valid regulations of the responsible electricity supply company.
- When connecting the unit to the electrical supply, check the compressor direction of rotation (see chapter "Maintenance" -> Check turning direction).
- Fuse the motor correctly (see table; use slow-blow fuses).

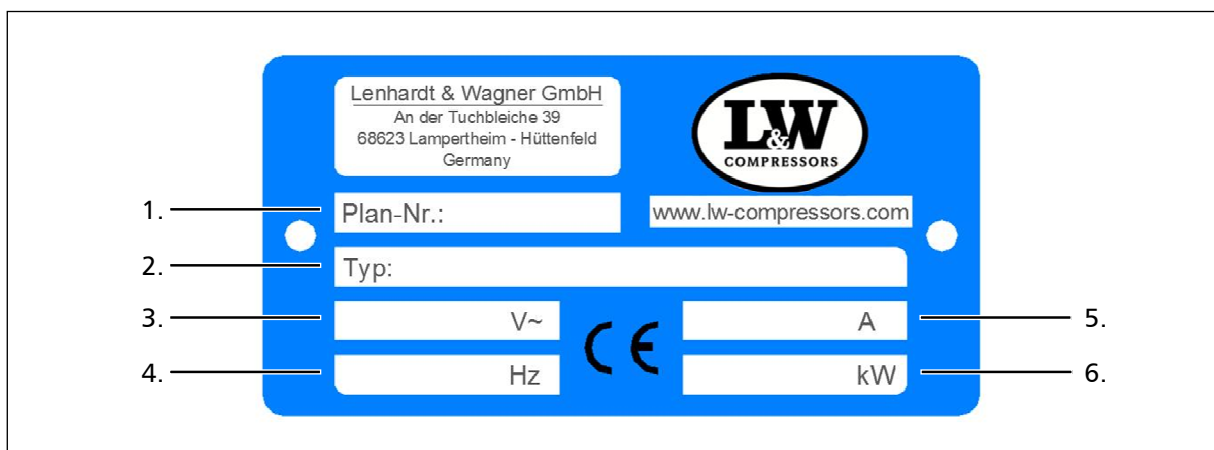

Fig. Compressor name plate

No.	Designation
1.	Circuit diagram number
2.	Compressor type
3.	Power supply
4.	Frequency
5.	Motor current consumption
6.	Nominal motor power

INSTALLATION

Electrical Installation

The standard compressor version is prepared for the connection to three phases (brown, black, grey), neutral conductor (blue) and protective earth conductor (green/yellow).

Fig. - Connection to the switch box

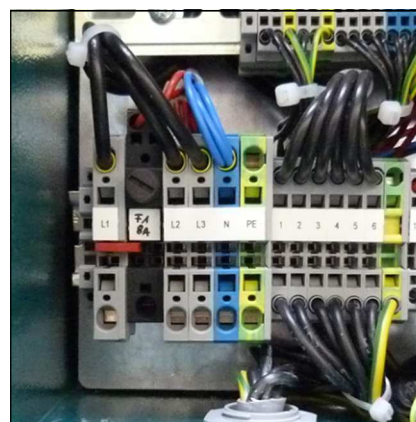

A

Recommended fuses for 360 - 500 V operating voltage

Nominal motor power		Fusing start A		Connection in mm ²	
[kw]	[A]	Direct	Star/Delta	Contactor supply	Motor S/D
2.2	5	10	-	1.5	1.5
4	8.5	20	-	2.5	1.5
5.5	11.3	25	20	2.5	1.5
7.5	15.2	30	25	2.5	1.5
11	21.7	-	35	4	2.5
15	29.9	-	35	6	4
18.5	36	-	50	6	4
22	41	-	50	10	4
30	55	-	63	10	6

Recommended fuses for 220 - 240 V operating voltage

Nominal motor power		Fusing start A		Connection in mm ²	
[kw]	[A]	Direct	Star/Delta	Contactor supply	Motor S/D
2.2	8.7	20	-	1.5	1.5
4	14.8	25	-	2.5	1.5
5.5	19.6	35	25	4	2.5
7.5	26.4	50	35	6	4
11	38	-	50	6	4
15	51	-	63	10	4
18.5	63	-	80	16	6
22	71	-	80	16	6
30	96	-	125	25	10



A

OPERATION



OPERATION

Important operation instructions



Note

Ensure that all persons handling the compressor are familiar with function and operation of the unit.



Wear hearing protection

When working on a running machine, always wear hearing protection.

A

FIRST COMMISSIONING

A

Prior to first commissioning, observe the following:

Necessary steps are described on the next page.

- Ensure that cooling air can flow freely.
- Check compressor oil level by the oil sight glass (see next page).
- Check all connections and retighten if necessary.
- Check if the filter cartridge is in place (see "Service and Maintenance").
- Check the V-belt tension (see next page).
- Check if all filling valves are closed. Open one filling valve and hold tight manually!

Start the compressor

1. Start the compressor by pushing the ON button.
2. Check turning direction - see the rotary direction arrow on the housing of the electric motor (see next pages). If the turning direction is wrong, immediately stop the compressor by pushing the OFF button and contact an authorised electrician.



Warning

Wrong impeller rotation direction!

Immediately after switching the compressor on, check the rotation direction. Depending on the place of installation, the phase sequence can influence the rotation direction.

3. Check oil pressure (if oil pressure gauge is installed).
4. Run the compressor for about 2 minutes.
5. Close the open filling valve carefully.
6. Run the compressor up to maximum pressure and check if the safety valve opens at the adjusted set pressure. (The set pressure value is engraved on the knurled screw of the safety valve.) If this function can not be ensured, the unit must be immediately taken out of service. - > Change safety valve!
7. Stop the compressor by pushing the OFF button.
8. Check the compressor unit for leaks (little smoke emission and release noises from the inlet filter housing can be ignored).
9. Now check the condensate drain valves:
 - Fix the black condensate hoses
 - Open manual condensate drain valves
 - If correct, air escapes
10. Open all filling valves carefully to vent.

FIRST COMMISSIONING

Check oil level



Warning

Check oil level daily. Never start the compressor with a too low oil level. Risk of accidental loss, destruction or deterioration.

Check oil before each operation of the system!

The oil level should be between the middle and upper end of the oil sight glass. Never start the compressor with a too low oil level.

Refill new compressor oil at least when the oil level reached the middle of the indicated area.

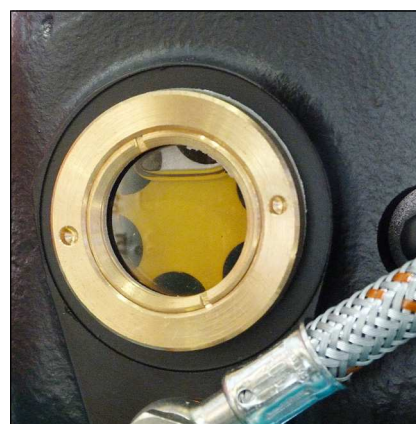

Oil sight glass

Check V-belt tension

The V-belt could lose tension during transportation. Please check the V-belt tension before starting the compressor.

Tension V-belt

To tighten V-belt tension, loosen 4 mounting nuts of the drive motor. Use the tensioning screw to move the electric motor until the V-belt tension is sufficient. Then, tighten mounting nuts and check V-belt tension.

We recommend using a V-belt tension gauge.

Correct V-belt tension

Do not tension V-belt too tight. This damages bearings of compressor and motor. The V-belt should only be tensioned until there is no noise caused by slipping during start.

Settings

Motor Type	Initial Installation	Operation after running in
Electric motors 50Hz	600 N	450 N
Electric motors 60Hz	500 N	400 N

FIRST COMMISSIONING

Check turning direction



Warning

Wrong impeller rotation direction!

Immediately after switching the compressor on, check rotation direction. Depending on the place of installation, the phase sequence can influence the rotation direction.

Before starting the compressor for the first time, check rotation direction (see the rotary direction arrow on the housing of the electric motor).

If the direction of rotation is wrong, the guide pistons of the 2nd and 3rd stages can not be sufficiently lubricated, with the consequence that the pistons will be damaged. Furthermore, cooling air flow will not be sufficient.

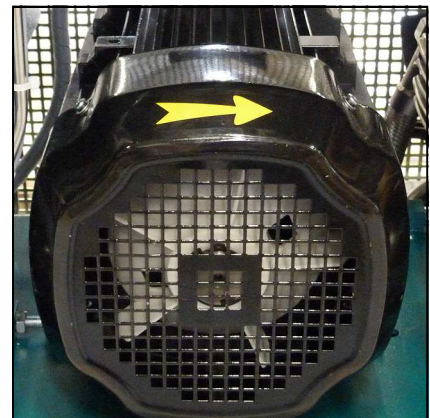

Rotation direction arrow

A



DAILY COMMISSIONING

Prior to daily operation observe the following:

- Ensure cooling air can flow freely.
- Check compressor oil level by the oil sight glass.
- Check if filter cartridge is in place / observe filter cartridge life!
- Ensure toxic-free, pure intake air.

A

OPERATION

Filling procedure

**Caution! Fill only cylinders which:**

- are marked with the test mark and the test stamp of the expert.
- have been hydrostatic tested (check last test date).
- are rated for the final pressure.
- are free from humidity.

**Note**

The unit must be stopped manually when final pressure is reached. No serial auto shut down. The unit must also be started manually.

**Caution**

Vent condensate drain valves every 15-30 minutes manually.

1. Close all filling valves.
2. Connect the closed compressed air cylinders.
3. Open cylinder valves.
4. Start the compressor by pushing the ON button.
5. When filling pressure gauge increases, open filling valves slowly.
6. Fill the compressed air cylinders to the desired pressure; subsequently close the filling valves slowly.
7. Switch off the compressor.
8. Close and vent all filling valves.
9. Disconnect all compressed air cylinders from filling valves.
10. Open condensate drain valves manually.



OPERATION

Switch off the compressor

The compressor unit is not equipped as standard with an auto shut down. The unit must always be stopped manually when final pressure is reached.

During filling process, the system can be shut down at any time by pushing the red button (OFF) or the emergency stop (only in case of emergency!).



Note

After switching off, open condensate drain valves manually to vent the unit.

A



A

REMEDYING FAULTS

REMEDYING FAULTS

A

Final pressure can not be reached

Cause of fault	Remedy
Connections leaky	Retighten or clean/replace if necessary
Final pressure safety valve leaky	Replace
Pipes / heat exchanger broken	Replace
Condensate drain valves leaky	Unscrew valves, check sealing surfaces, clean, replace if necessary
Final pressure switch stop unit	Verify settings, replace if necessary
Piston of pneumatic condensate valve sticks	Clean pneumatic condensate valve and restore function, check/replace o-rings, replace valve completely if necessary

Strong compressor vibration

Cause of fault	Remedy
V-belt tension too loose	Tension V-belt
Drive motor / Compressor unit loosely	Retighten mounting screws
Anti vibration mounts used up	Replace
Ground not levelled	Ensure a solid and level ground

Air supply too low

Cause of fault	Remedy
Inlet and outlet valves contaminated / defective	Clean, replace if necessary
Cylinder(s), piston(s) or piston ring(s) used up	Replace
V-belt slips	Tension V-belt
See chapter "Final pressure can not be reached"	See chapter "Final pressure can not be reached"



REMEDYING FAULTS

Compressor overheated

Cause of fault	Remedy
Inlet filter cartridge contaminated	Replace
Ambient temperature too high	Improve room ventilation / Reduce operation times
Cooling air inlet and outlet insufficient	Observe minimum distances (see Installation Instructions)
Air intake hose too long	Reduce length of the air intake hose
Air intake hose diameter too small	Use a larger diameter
Wrong compressor rotation direction	Ensure correct phase rotation, observe rotation direction arrow!
Inlet and outlet valves contaminated / defective	Clean, replace if necessary

Safety valve leaks

Cause of fault	Remedy
Inlet and outlet valves of the following pressure stage defective	Clean, replace if necessary
Sinter filter of the following water separator blocked	Replace
Safety valve leaky	Replace

Oil taste in the air

Cause of fault	Remedy
Mole carbon filter cartridge saturated	Replace
Compressor oil unsuitable	Use prescribed oil quality
Filter cartridge unsuitable	Use prescribed filter type
Cylinder(s), piston(s) or piston ring(s) defective	Replace

REMEDYING FAULTS

Automatic condensate drain defective

Cause of fault	Remedy
Solenoid coils defective	Replace
Cable / supply cable defective	Repair, replace if necessary
Timer / relais defective	Replace
Sinter filter of pneumatic condensate valve blocked	Replace
Piston of pneumatic condensate valve sticks	Clean pneumatic condensate valve and restore function, check/replace o-rings, replace valve complete if necessary

Condensate drain starts before reaching final pressure

Cause of fault	Remedy
Pressure stages are not as prescribed, control pressure of pneumatic condensate valve too low	Check corresponding inlet and outlet valve, replace if necessary.
Piston sealing of pneumatic condensate valve contaminated / used up	Clean, replace if necessary
Timer / relais settings not correct	Adjust as prescribed
Timer / relais defective	Replace

Compressor stops before final pressure

Cause of fault	Remedy
Final pressure switch settings not correct	Correct settings
Opening pressure of the pressure maintaining valve too high	Correct settings
Fuse / circuit breaker has tripped Valid only for E models	Check fusing of the power supply / observe regulations
Emergency stop switch has tripped	Unlock emergency stop switch, close compressor housing door correctly



REMEDYING FAULTS

Filter life not sufficient

Cause of fault	Remedy
Pressure maintaining valve settings not correct	Adjust as prescribed
Filter cartridge unsuitable	Replace by a prescribed filter cartridge type
Filter cartridge too old	Observe expiration date
Filter cartridge packaging incorrect / damaged / already opened. Filter cartridge already partly saturated before change	Store filter cartridges properly, dispose defective cartridges
Operating temperature too high	Ensure sufficient ventilation
Cylinder(s), piston(s) or piston ring(s) defective	Replace

Oil consumption too high

Cause of fault	Remedy
Cylinder(s), piston(s) or piston ring(s) defective	Replace
Compressor oil unsuitable	Use prescribed oil quality
Operating temperature too high	Observe prescribed operating temperatures
Oil leak at the compressor block	Tighten corresponding mounting screws, if necessary replace corresponding paper sealing / o-ring / shaft seal

A



A

MAINTENANCE AND SERVICE

MAINTENANCE AND SERVICE

Service, Repair and Maintenance

Carry out service and maintenance work exclusively when the compressor is stopped and depressurised. The unit should be leak-checked regularly. Leaks can be preferably localised by using a leak detector spray (if necessary, brush pipes with soapy water).

We recommend that only authorised L&W service technicians carry out service work on the bearing of the compressor (crankshaft and connecting rods).

We urgently recommend that all maintenance, repair and installation work must only be carried out by trained personnel. This is necessary because all maintenance work can not be explained exactly and detailed in this manual.

Only use authentic spare parts for service work.



Danger

Components under pressure, such as hose ends, can quickly come loose when manipulated and can cause potentially fatal injuries due to the pressure surge. Any work on system parts may only be performed in a pressure-compensated state.



Warning

The use of accessories that have not been tested can lead to death or serious injury or damage to the unit. Only use authentic spare parts for service work.



Warning

Carry out maintenance or service work when the unit is switched off and protected against unexpected restart.



Warning

Risk of burns!

Carry out maintenance or service work when the unit has cooled down.



MAINTENANCE AND SERVICE

Daily before taking unit into operation

Maintenance work	Type	Quantity	Order No.
Check oil level	-	-	000001
Check condition of all filling hoses	-	-	-
Check filter cartridge lifetime	-	-	-
Operate unit to final pressure and check function of final pressure switch	-	-	-

Every 3 months or as required

Maintenance work	Type	Quantity	Order No.
Check/Retorque all connections and bolts	-	-	-

Annually

Maintenance work	Type	Quantity	Order No.
Oil change, if less than 1000 operating hours	-	2.2	000001
Check opening pressure of final safety valve	-	-	-
Clean coolers	-	-	-
Clean all oil/water separators, if less than 500 operating hours	-	-	-
Service intake filter (depends on condition - if less than 500 operating hours)	-	-	-
Check all connections for leakage	-	-	-



MAINTENANCE AND SERVICE

Every 500 operating hours

Maintenance work	Type	Quantity	Order No.
Change intake filter	-	1	000170
Check pressure maintaining/non-return valve	-	-	-
Check V-belt tension and condition	-	-	-

A



MAINTENANCE AND SERVICE

Every 1000 operating hours

A

Maintenance work	Type	Quantity	Order No.
Replace V-belt	LW 450 E Compact (50Hz)	1	001409
	LW 450 E Compact (60Hz)	1	001453
Replace sintered metal filter element of water separators	1st stage	1	000184
	2nd stage	1	000173
Replace o-rings of water separators	1st stage	1	001294
	2nd stage	3	001272
Replace o-ring of oil separator	-	1	001294
Replace silencer	-	1	000178
Replace sintered metal filter of oil separators	-	1	000184
Replace sintered metal filter of pneumatic condensate valve	-	1	000188
Replace oil sieve / oil pump cover gasket	-	1	002569
Oil change	-	2.2	000001
Replace o-rings of the final filter housing	-	2	001287
Replace back-up rings of the final filter housing	-	2	001285



MAINTENANCE AND SERVICE

Every 4000 operating hours (Latest in 10 years)

A

Maintenance work	Type	Quantity	Order No.
Replace all o-rings and gaskets of 1st, 2nd and 3rd stage	gasket	3	000240
	o-ring	1	001274
Replace all inlet and outlet valves incl. gaskets	1st stage	1	000259
	2nd stage	1	000256
	3rd stage	1	000524
	Upper gasket 1st	1	000257
	Upper gasket 2nd	1	000254
	Lower gasket 1st	1	000258
	Lower gasket 2nd	1	000253
Replace oil intake hose	-	1	000376
Replace needle bearings for conrod 2nd and 3rd stage	-	2	003836
CU-Ring (Ø10 x 16 x 2mm)	-	1	001323
CU-Ring (Ø10,4 X 13,4 X 1mm)	-	1	001324
CU-Ring (Ø13,5 x 18 x 1,5mm)	-	1	001327
CU-Ring (Ø14,5 X 20 X 1,5mm)	-	1	001329

MAINTENANCE AND SERVICE

Service Kits

The service kits contain parts for maintenance according to the factory requirements.

The use of the service kits ensures that all required parts are ordered and replaced and gives assurance that all parts are included in the order. Depending on the model and interval, the service kits include parts such as O-Rings, Sinter Filter, Inlet Filter, V-Belts, Silencers, In-&Outlet Valve, Valve Seals and Compressor oil.



Service Kits

A

Service Kits LW 450 E Compact for 50 Hz

Compressor	Frequency	Operating Hours	Order No.
LW 450 E Compact	50 Hz	1000 h	003841
LW 450 E Compact	50 Hz	4000 h	003834

Service Kits LW 450 E Compact for 60 Hz

Compressor	Frequency	Operating Hours	Order No.
LW 450 E Compact	60 Hz	1000 h	006718
LW 450 E Compact	60 Hz	4000 h	006719



MAINTENANCE AND SERVICE

Check V-belt tension

The V-belt could lose tension during transportation. Please check the V-belt tension before starting the compressor.

Tension V-belt

To tighten V-belt tension, loosen 4 mounting nuts of the drive motor. Use the tensioning screw to move the electric motor until the V-belt tension is sufficient. Then, tighten mounting nuts and check V-belt tension.

We recommend using a V-belt tension gauge.

Correct V-belt tension

Do not tension V-belt too tight. This damages bearings of compressor and motor. The V-belt should only be tensioned until there is no noise caused by slipping during start.

Settings

Motor Type	Initial Installation	Operation after running in
Electric motors 50Hz	600 N	450 N
Electric motors 60Hz	500 N	400 N

MAINTENANCE AND SERVICE

Compressor lubrication

Crankshaft bearings of the 1st and 2nd stage get lubrication by an oil slinger. In addition, 1st and 2nd stage are lubricated by spray oil. The guide cylinder of the 3rd stage is lubricated by a mechanical oil pump.

A

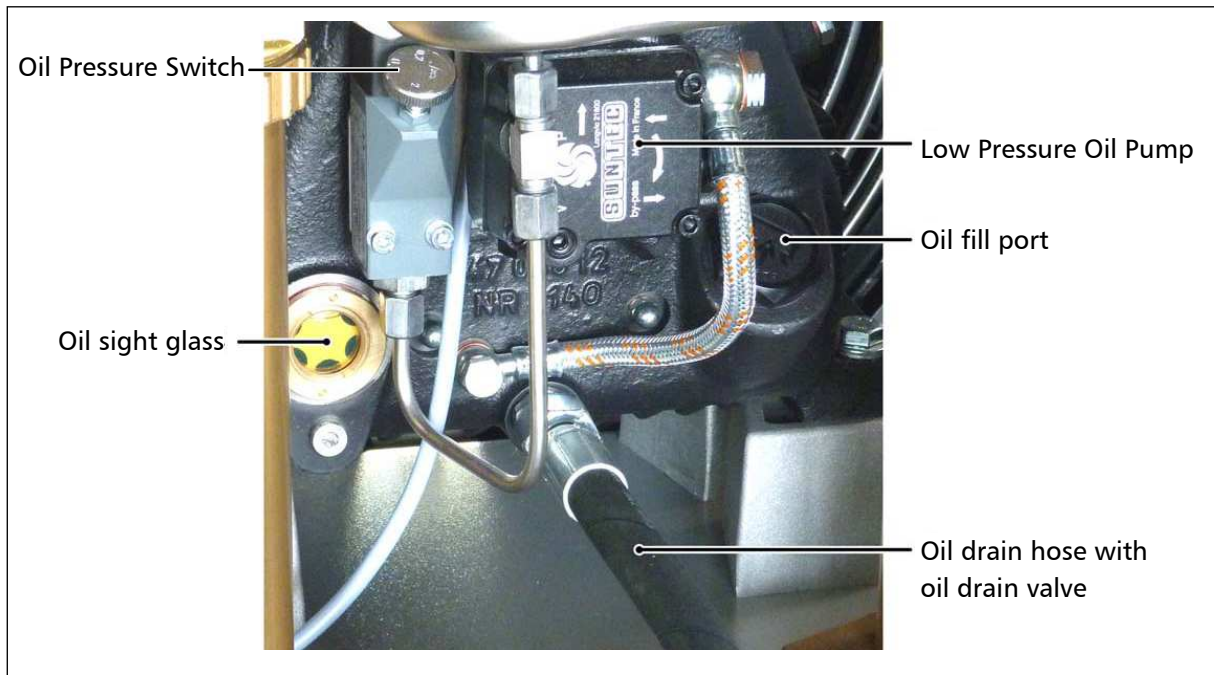

Lubricating System

Check oil level



Warning

Check oil level daily. Never start the compressor with a too low oil level. Risk of accidental loss, destruction or deterioration.

Check oil before each operation of the system!

The oil level should be between the middle and upper end of the oil sight glass. Never start the compressor with a too low oil level.

Refill new compressor oil at least when the oil level reached the middle of the indicated area.

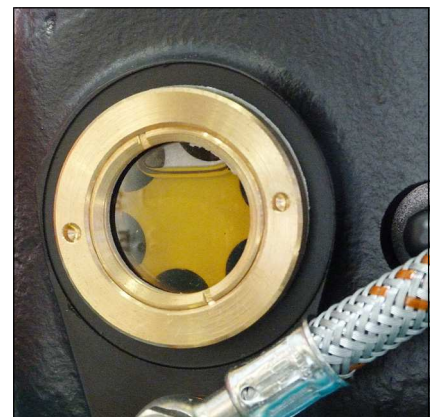

Oil sight glass



MAINTENANCE AND SERVICE

Oil change



Note

We recommend oil change at least once a year - depending on total operating hours.

A

Oil change as follows:

- Run compressor warm for approx. 2 min.
- Switch off and vent compressor.
- Place a suitable oil drain tray under the drain hose.
- Open carefully oil drain valve and drain oil completely.
- Close oil drain valve.
- Loosen oil fill port with an appropriate adjustable wrench (AF 0-40 mm) and unscrew manually.
- Fill oil by using a funnel.
- Check oil level. The oil level should be between the middle and upper end of the oil sight glass.
- Screw oil fill port manually in and tighten with the adjustable wrench.

The oil change is now completed.

Maintenance intervals

- First oil change after 25 operating hours (total hours).
- All further changes after each 1,000 operating hours.

Oil and oil capacity

Approx. 2,200 ml synthetic compressor oil is necessary for one oil change. Only use synthetic compressor oil which is recommended as suitable from L&W.

MAINTENANCE AND SERVICE

A

Oil sieve change

Oil sieve change as follows:

- Loosen cover screws (4 pcs).
- Remove the cover, the cover gasket and the oil sieve.
- Clean the oil sieve with petroleum-ether or replace the defective oil sieve.
- Replace the gaskets.
- Soak the gaskets with oil before placing (respect mounting direction).
- Be sure to position the arrow (see Fig., Pos. 1) from the new oil sieve opposite to inlet and return ports of the pump (see Fig., Pos. 2).
- Remount the cover with the 4 cover screws. Tightening torque: 4.5 - 8 N.

The oil sieve change is now completed.

Maintenance intervals

- We recommend cleaning or replacing the oil sieve every 1,000 working hours.
- Service Kit oil pump (002569). Consists of: 000798—Oil sieve + 000672—oil pump cover gasket

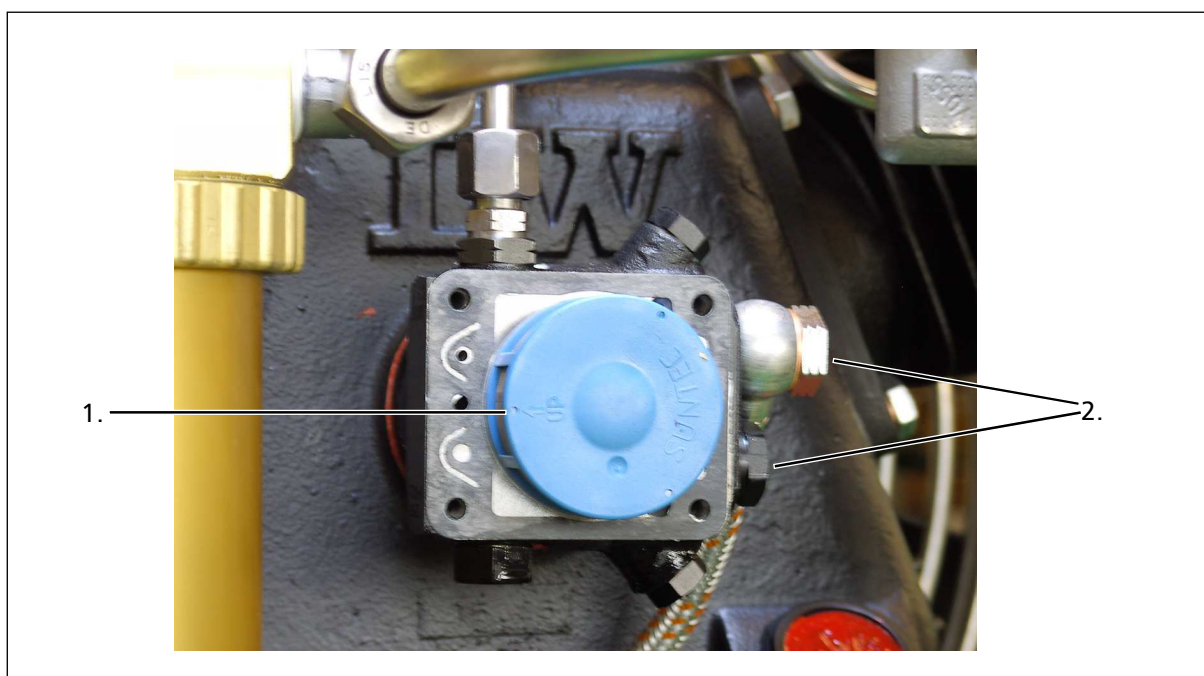

Correct oil sieve mounting direction

MAINTENANCE AND SERVICE

Manual condensation dump system



Note

The collected condensate can contain oil and has to be disposed according to regulations.

Oil- / water separators

The LW 450 E Compact comes as standard with an automatic condensation dump system. Drain condensate separators every 15 minutes.

To release the complete condensate through the black plastic hoses we recommend using a 20 l container at least.

The drain noise can be kept to a minimum by using a silencer.

Manual drain



Warning

Open valve spindle max. 1.5 turns.
The pressure in the housing can shoot out the valve spindles at high speed.

To drain manually, open the condensate drain valves of the 1st and the 2nd stage of the oil / water separators and the condensate drain valve of the filter housing (Fig. 2).

Open valve spindle max. 1.5 turns anti-clockwise. The condensate will be drained.

Then close valve spindle clockwise.

Maintenance intervals

We recommend to clean oil and water separators every 500 operating hours or at least once a year, to check for corrosion damage and to replace o-rings if necessary.

All oil / water separators have an integrated sinter filter which has to be replaced every 1,000 operating hours.

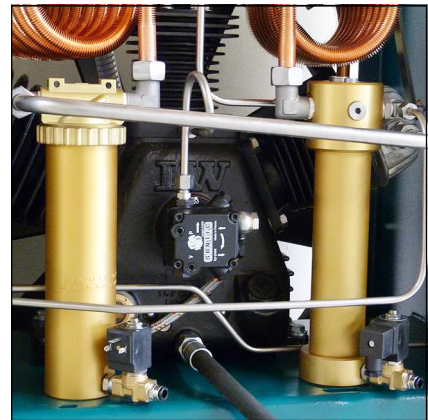

Fig. 1 Oil / water separators 1st and 2nd stage with automatic condensate drain system

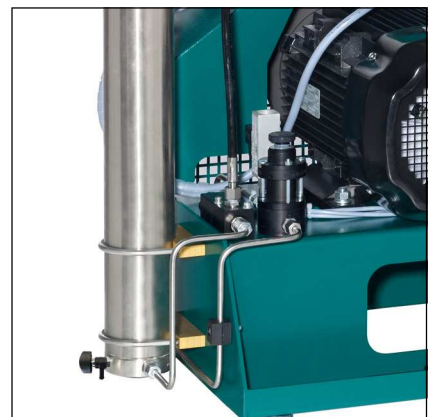

Fig. 2 - Condensate drain valve of the filter housing



Fig. 3 - Condensate drain valve

A

MAINTENANCE AND SERVICE

Oil / water separator 1st stage - maintenance



Note

Clean all parts thoroughly before assembly.

Change / clean oil / water separators 1st stage as follows:

- Loosen pipe connections and mounting screws.
- Remove oil / water separators.
- Open ring nut and remove separator top (Fig. 1).
- Open nut and remove separator top (Fig. 2).
- Change sinter filter (Fig. 3).
- Reassemble all parts and tighten nut.
- Change o-ring, previously grease new o-ring (Fig. 4).
- Place separator top and tighten ring nut manually.
- Mount oil / water separators.
- Tighten pipe connections and mounting screws.

Oil / water separator maintenance is now completed.

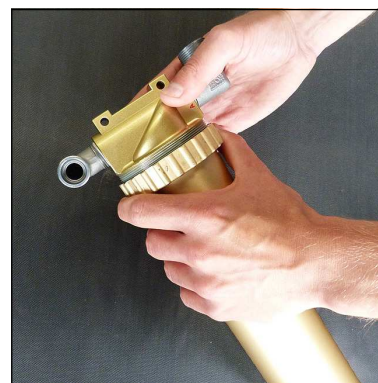

Fig. 1 - Open ring nut and remove separator top



Fig. 2 - Loosen nut at the separator top

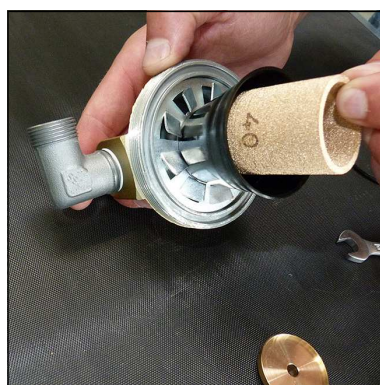

Fig. 3 - Change sinter filter



Fig. 4 - Change o-ring

MAINTENANCE AND SERVICE

Oil / water separators 2nd stage - maintenance



Note

Clean all parts thoroughly before assembly.

Maintenance / cleaning of oil / water separators 2nd stage as follows:

- Loosen pipe connections and mounting screws.
- Remove oil / water separators.
- Unscrew and remove filter top (Fig. 1).
- Open nut and remove separator top (Fig. 2).
- Change sinter filter (Fig. 3).
- Reassemble all parts and tighten nut.
- Change o-ring, previously grease new o-ring (Fig. 4).
- Place separator top and tighten manually.
- Remove bottom part (Fig. 5)
- Change o-ring, previously grease new o-ring
- Press in bottom part
- Mount oil / water separators.
- Tighten pipe connections and mounting screws.

The oil / water separator maintenance is now completed.



Fig. 1 - Unscrew and remove filter top



Fig. 2 - Loosen nut at the separator top



Fig. 3 - Change sinter filter

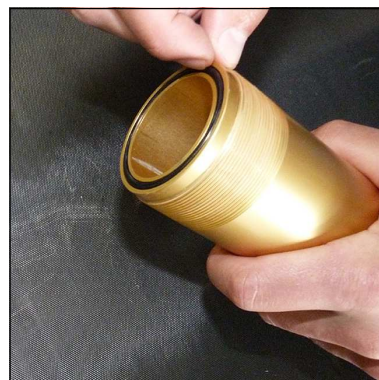

Fig. 4 - Change o-ring



Fig. 5 - Bottom part

MAINTENANCE AND SERVICE

Filter housing

The mole carbon filter housing is installed on the right hand side of the compressor housing.

Inside the filter housing a jet blows air on to the housing wall. Condensation water and oil are led by centrifugal force to the bottom of the housing. Air flows through the mole carbon filter cartridge, which purifies the air from residual moisture and odours.

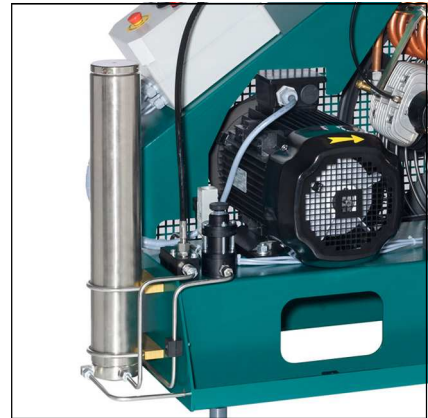

Filter housing

Filter cartridge

The high-pressure compressor is equipped with an integrated breathing air purification system. Air is compressed up to 330 bar, dried and odour- and tasteless purified. Oil residues are bounded. The breathing air filter cartridge consists of a molecular sieve and activated-carbon filter.

Cartridge capacity: approx. 1.7 l

All breathing air filter cartridges are factory vacuum sealed.

We recommend unpacking the filter cartridges just before installation. Filter cartridges which are exposed too long could be saturated with moisture and become unusable.

Maintenance intervals

Filter cartridges should be changed at the following intervals, at +20°C or more often, depending on humidity and ambient temperature:

- 33 hours for LW 450 E Compact

MAINTENANCE AND SERVICE

Filter cartridge change

Filter cartridge change as follows:

- Run the compressor up to a pressure of 100 bar.
- Stop compressor.
- Open filling valve.
- Unscrew filter housing cover by using the special filter tool (Fig. 1).
- Place the T-piece end of the filter tool in the recess of the filter cartridge (Fig. 2).
- Unscrew the filter cartridge anti-clockwise and pull the cartridge out of the housing (Fig. 3).
- Open the packing of the new filter cartridge and place it with the filter tool in the filter housing.
- Screw the new filter cartridge hand tight in by using the filter tool.
- Screw the cover of the filter housing first manually in.
- After it has been completely screwed in, turn cover anticlockwise for 90°. This avoids tightening of the cover due to vibration..

The filter cartridge change is now completed.



Note

Ensure that the old filter cartridge is disposed correctly at an approved waste point.



Fig. 1 - Unscrew the filter housing cover.



Fig. 2 - Place the T-piece end of the filter key in the top of the filter cartridge.



Fig. 3 - Pull the cartridge out of the housing.

A

MAINTENANCE AND SERVICE

Filter housing - maintenance



Note

Clean all parts thoroughly before assembly.

Filter housing maintenance as follows:

- Open Filter Cover (Fig. 1).
- Change o-ring and back-up ring, previously grease both (Fig. 2).
- Grease filter cover thread and close.

Dismount filter housing

- Loosen pipe connections and nuts (Fig. 3).
- Remove filter housing.
- Dismount filter housing base.
- Change o-ring and back-up ring, previously grease both (Fig. 4).
- Screw filter base tight in.

Mount filter housing

- Connect pipe connections and tighten.
- Adjust holding clamp and tighten nuts.

The filter housing maintenance is now completed.



Fig. 1 - Open Filter cover

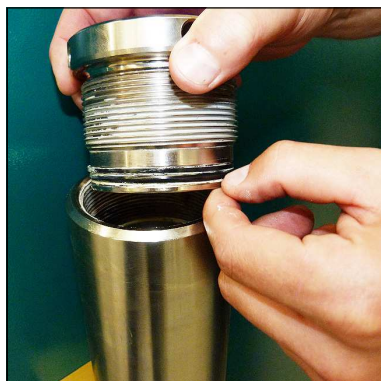

Fig. 2 - Change o-ring and back-up rings

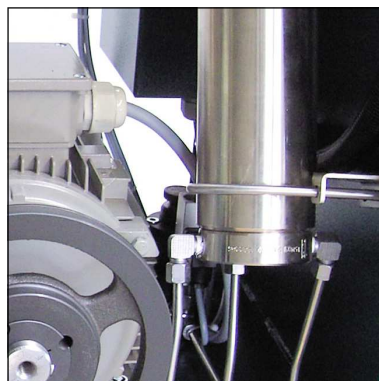

Fig. 3 - Loosen pipe connections and nuts



Fig. 4 - Change o-ring and back-up rings

MAINTENANCE AND SERVICE

Inlet filters



Note

Dirty filters make intaking air difficult and reduce delivery capacity. Risk of compressor overheating.

A micro filter cartridge is used as an air inlet filter. Check air inlet filter regularly or replace it. Defective air inlet filters should be immediately replaced with a corresponding filter.

Maintenance intervals

We recommend that the filter cartridge should be replaced every 1,000 working hours (depending on pollution grade).

Inlet filter cartridge change

Inlet filter cartridge change as follows:

- Loosen cover by pushing the three clips apart.
- Remove inlet filter cartridge and replace it by a new one.
- Refit cover and snap the three clips until a loud 'click' can be heard.

The inlet filter cartridge change is now completed.

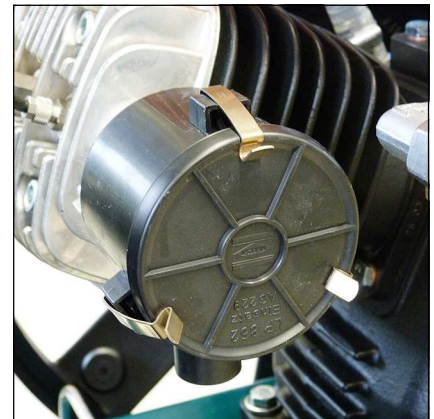

Air filters

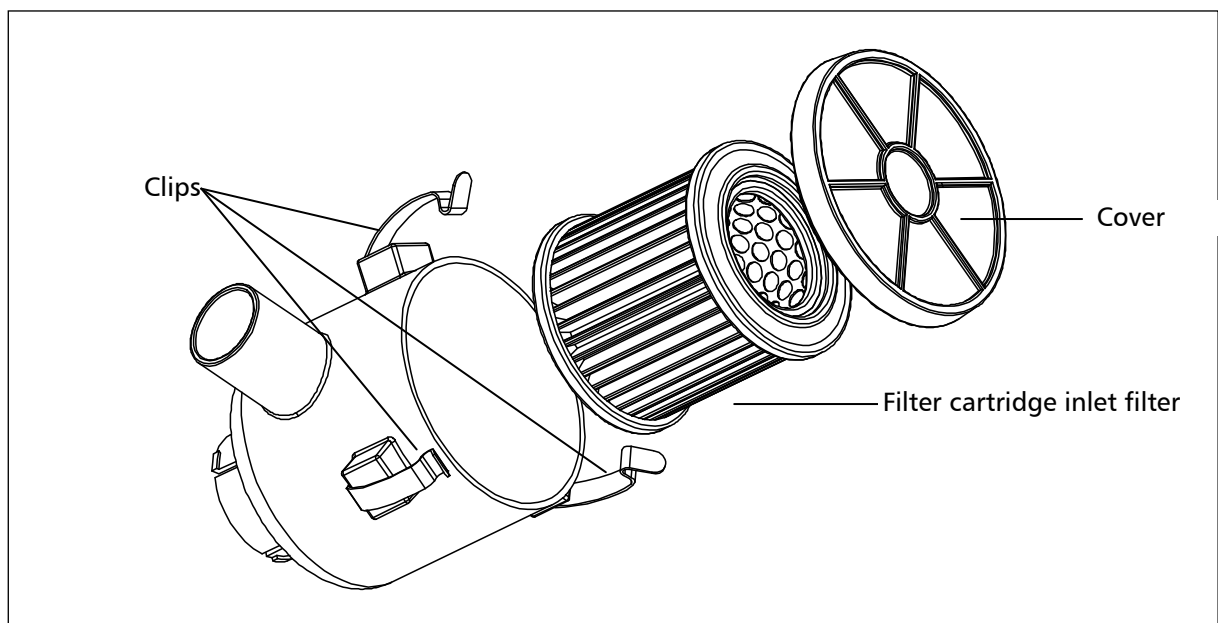

Filter cartridge inlet filter

MAINTENANCE AND SERVICE

Cylinder heads and valves

Inlet and outlet valves of the specific compressor stages are located between valve head and cylinder. Outlet valves open while piston downstroke, inlet valves open while upstroke or compression stroke.

Valves are subject to normal wear and tear and have to be replaced at certain intervals (depending on specific operating conditions). Dismount valve heads to change valves. The three valves are combined inlet and outlet valves. The first and second stage valves are plate valves. The third stage contains a spring operated piston which acts inside a bronze cylinder.



Valve head 3rd stage

Maintenance intervals

All valves should be replaced after 4,000 working hours due to normal wear and tear. To replace valves the cylinder heads have to be removed. There are no special tools required to replace these valves.

Available special tools

Special tools are not necessary for dismounting inlet and outlet valves but make work easier.

Order number: 006847



Special tool

MAINTENANCE AND SERVICE

Replace inlet and outlet valves 1st and 2nd stage



Note

The figures of the parts can differ due to the different stages.

Change inlet and outlet valves 1st and 2nd stage as follows:

Remove Inlet / Outlet Valve

- Loosen pipe connections
- Loosen valve head screws (Fig. 1)
- Remove valve head
- Pull out inlet and outlet valve (Fig. 2). CAUTION: Observe that the lower copper valve ring is also pulled out. (It can still stick inside the cylinder)
- Check valve head if defective

Install Inlet / Outlet Valve - see following page

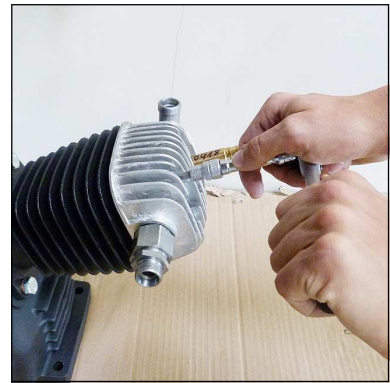

Fig. 1 - Loosen valve head screws



Fig. 2 - Pull out inlet and outlet valve

Replace inlet and outlet valves 1st and 2nd stage - continued from previous page

A



Caution

The exact alignment of upper and lower valve gasket is very important. Inlet and outlet channels have to be exactly centred. Do not turn inlet and outlet valve after insertion. The copper valve ring could cover outlet channels.

Install Inlet / Outlet Valve

- Grease the lower valve gasket slightly and place on the new inlet and outlet valve.
CAUTION: Observe correct copper valve ring position (centre inlet and outlet channels).
- Place the new inlet and outlet valve straightly into the cylinder (Fig. 3).
CAUTION: Do not turn the inlet and outlet valve inside the cylinder! The copper valve ring could cover outlet channels!
- Place the upper valve gasket on the inlet and outlet valve.
CAUTION: Observe the correct paper gasket position (centre inlet and outlet channels). (Fig. 4)
Note: Valve head screws can be inserted into the valve head to secure the upper valve gasket.
- Refit the valve head and tighten the valve head screws crosswise.

Starting torques:

1. nd Stage 45 Nm
2. nd Stage 30 Nm

The replacement inlet and outlet valves 1st and 2nd stage is now completed.

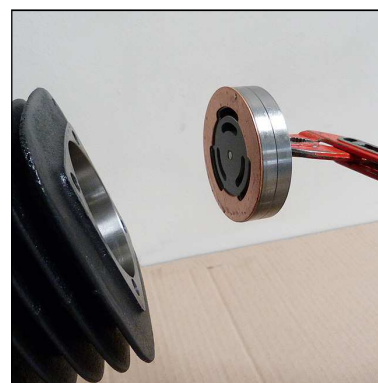

Fig. 3 - Place new inlet and outlet valve straightly into cylinder



Fig. 4 - Ensure the correct mounting position of the paper gasket

MAINTENANCE AND SERVICE

Replacement inlet and outlet valves 3rd stage

Replacement inlet and outlet valves 3rd stage as follows:

- Loosen pipe connections
- Loosen valve head screws (Fig. 1)
- Remove lower valve gasket (Fig. 2)
- Dismount inlet and outlet valve (Fig. 3). Observe that the upper valve gasket is also pulled out. (It can still stick inside the cylinder head)
- Check valve head if defective (check centre pin)
- Mount valve gasket on inlet and outlet valve.
CAUTION: Ensure correct mounting position of the upper valve gasket (Fig. 4).
- Insert new inlet and outlet valve into valve head.
CAUTION: Observe correct position between valve centre hole and valve head centre pin.
- Place bottom valve gasket
- Place valve head with the new inlet and outlet valve. Tighten valve head screws crosswise (tightening torque 30 Nm).

Replacement inlet and outlet valves 3rd stage complete.



Fig. 1 - Loosen valve head screws



Fig. 2 - Remove lower valve gasket



Fig. 3 - Remove inlet and outlet valve



Fig. 4 - Ensure correct mounting position of the upper valve gasket

A

MAINTENANCE AND SERVICE

Safety valves

Every pressure stage is equipped with a separate over pressure safety valve. Safety Valves avoid a non permissible high pressure at the specific pressure stages and limit maximum operation pressure of the compressor.

Safety valves are adjusted to:

- 1st Stage: 8 bar
- 2nd Stage: 50 bar
- 3rd Stage: max. final pressure

The adjusted blow-off pressure [bar] of the safety valves is indicated on their housings.

All safety valves are factory sealed with special L&W safety seals to avoid manipulation of the limit value settings.

Safety valves with removed seals have to be immediately checked for the prescribed settings and replaced if necessary.

The safety valve of the final stage is furthermore equipped with a knurled screw to be activated once.

Turning the knurled screw clockwise could vent the valve completely and therefore the final filter housing.

During normal operation conditions, the knurled screw has to be turned anti-clockwise up to the upper stop. An integrated circlip avoids complete unscrewing.

If a safety valve blows off, it indicates problems with either inlet or outlet valve of the following stage.



Note

Replace defective safety valves immediately!

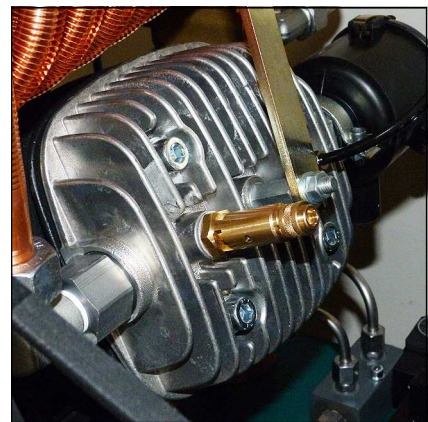

Safety valve 1st stage

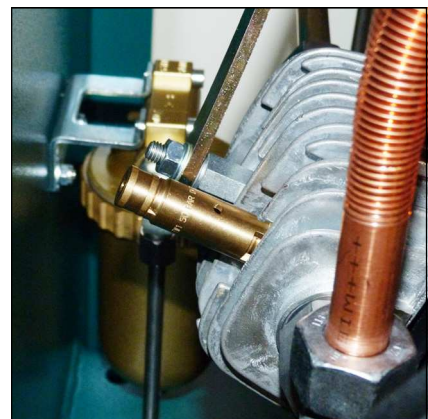

Safety valve 2nd stage



Safety valve 3rd stage

A

Pressure maintaining / non return valve

**Note**

If the adjusted opening pressure of the pressure maintaining valve is higher than the final pressure of the compressor, the final pressure safety valve blows off before pressure maintaining valve opens (final pressure = 0 bar). When valve settings are not clear (e.g. after disassembly / repair), start the adjustment with a low basic setting (turn adjusting screw approx. 3 times in).

A pressure maintaining / non return valve is installed after the mole carbon filter housing. It maintains a pressure of at least 150 bar inside the filter housing - this optimises filter efficiency.

Pressure maintaining valve

The pressure maintaining valve drains a large part of the water content of the compressed air mechanically by ensuring the minimum outlet pressure. This guarantees optimal drying and purification of the breathing air.

After starting the compressor, the pressure inside the final filter housing constantly increases. The pressure maintaining valve prevents the compressed air from blowing off (final pressure gauge = 0 bar).

When the adjusted opening pressure is reached (150 and 180 bar), the purified compressed air flows via pressure maintaining and non return valve to the filling valve.

The value of the opening pressure of the pressure maintaining valve can be read at the final pressure gauge. When opening pressure is reached, the pressure gauge value increases within a few seconds.



Pressure maintaining/non-return valve

Test of pressure equipment

According to the Pressure Equipment Directive (PED 97/23/EC) and TÜV Darmstadt (German supervising authorities). State: 10th of December, 2005

Subject: pressure equipment with a product permissible operating pressure [bar] x content volume [litres] from 200 up to 1000.

Example: Filter housing 1.7 l

Maximum operating pressure: 350 bar

Content volume: 1.7 litres

$350 \text{ bar} \times 1.7 \text{ litres} = 595$

595 is smaller than 1000 -> result: Test is applicable!!

Example: Filter housing 2.3 l

Maximum operating pressure: 350 bar

Content volume: 2.3 litres

$350 \text{ bar} \times 2.3 \text{ litres} = 805$

805 is smaller than 1000 -> result: Test is applicable!!

Pressure equipment from 200 up to 1000 have to be tested as follows:

1. Examination after 5 years by a qualified person or authorized organisations.

Visual inspection, inside and outside.

2. Examination after 10 years by a qualified person or authorized organisations.

Visual inspection, inside and outside.

In addition, a water pressure test is carried out at 1.5 times of the permissible vessel operating pressure.



A

MAINTENANCE RECORDS



STORAGE

Conservation / storage of the compressor

If the compressor unit is not to be used for an extended period of time, we recommend to carry out the following work before storage time:

- Run the compressor at 200 bar filling pressure for approximately ten minutes (control the flow with the filling valve to maintain constant pressure).
- Replace compressor oil, open filling valve(s) and run compressor for a few minutes.
- Stop compressor and open drain valves (depending on the compressor type, this may happen automatically). Remove top cap of final filter housing: clean throat, grease o-ring and throat with a food grade grease or silicone grease. Close filter housing.
- Remove intake filter cartridge and undo intake pipes on all valve heads.
- Start compressor unit. Spray a few drops of compressor oil into intake connectors.
- Stop compressor unit and insert intake filter cartridge. Bring intake pipes back in position and fix connections and nuts. Close filling- and drain valves.
- Store the compressor in a cool dry place free from dust and contamination. A dust cover is recommended as long as condensation can be avoided.
- If compressor unit should be stored for a period of more than one year, an oil change is strongly recommended before it's been re-used.
- Fuel driven units only: fill up fuel tank to top level to avoid corrosion.

De-conservation, commissioning

After the compressor has been stored, the following steps are to be taken:

- If compressor hasn't been used for longer than 12 months, we strongly recommend an oil change before any use.
- Replace intake filter cartridge and check oil level.
- Clean compressor unit, check for foreign objects. Check condition and tension of V-belts, replace if necessary. Check condition of filling hoses, replace if necessary.
- Secure hoses against whipping and open filling valves and run compressor for approximately 10 minutes.
- Check condition of final filter cartridge, replace if necessary.
- Close filling valves and run compressor up to final pressure.
- Check safety valve relief pressure of final stage and/or pressure switch setting.
- Check all connections and pipe work for leaks.

Once all above steps are completed, compressor unit is now ready for use.

STORAGE

Transportation instructions

- Parts which need to be dismantled for transport purposes must be carefully replaced and secured before taking into operation.
- The transport may only be carried out by trained personnel.
- For transportation, only use lifting devices and equipment with sufficient lifting power.
- Do not stand or work under suspended loads.
- Also separate from minor relocation machinery / system of any external energy supply. Before recommissioning, reconnect the machine to the mains according to regulations.
- When recommissioning, proceed according to the operating instructions..

Disposal

The product must be disposed in accordance with national waste disposal regulations and by an appropriate waste disposal company.

Electric and electronic components

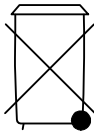

EU-wide regulations for the disposal of electric and electronic appliances which have been defined in the EU Directive 2002/96/EC and in national laws are effective from August 2005 and apply to this device.

Common household appliances can be disposed by using special collecting and recycling facilities. However, as this device has not been registered for household usage, it must not be disposed of through these means.

The device can be returned to L&W. Please do not hesitate to contact us if you have any further questions on this issue.

Operating Instructions

ECC - Electronic compressor control





TABLE OF CONTENTS

General Information

General Information	3
Description of Warning Symbols	3

Description

Specifications / Options	4
Switchboard	5

Operation and Function

Main Menu	6
Selection Menu (M100)	7
Display Menu (M200)	8
Inter-Stage Pressure Display.....	8
Display II (M270)	9
Settings Menu (M300).....	10
Set Stop Pressure - automatic mode (M320).....	11
Set Restart Pressure - automatic mode (M330).....	11
Set Stop Pressure - semi-automatic mode (M340)	11
Test Menu (M400)	12
Test Solenoids (M420)	12
Test safety valve (M430)	13
Test stop without venting (M440)	13
Statistics Menu (M500).....	14
Maintenance Menu (M600)	15
Confirm Maintenance (M680).....	16
Operation Mode (M700).....	17
Language Menu (M750)	17
Adjusting Display Backlight.....	18
Software Update	18
Spare part lists.....	19
Manufacturer in terms of 97/23/EC.....	20

B



GENERAL INFORMATION

General Information

We strongly recommend reading this manual thoroughly prior to operation and follow all the safety precautions precisely. Damage resulting from any deviation from these instructions is excluded from warranty and liability for this product. Carry out other commissioning steps only if you have fully understood the following contents.

Before commissioning and using the unit, carry out all the essential preliminary work and measures concerning legal regulations and safety. These are described on the following pages of this operation manual.

B

Description of marks and warning signs

The following warning signs are used in this document to identify the corresponding warning notes which require particular attention by the user. The warning signs are defined as follows:



Caution

Indicates an imminently hazardous situation which, if not avoided, could result in serious injury, physical injury or death.



Warning

Indicates a potentially hazardous situation which, if not avoided, could result in physical injury or damage to the product or environment.



Note

Indicates additional information on how to use the unit.



DESCRIPTION

Specifications and Options

All L&W compressors can be optionally equipped with the all-electrical computer supported control system "ECC". It is easy to operate and allows multiple and individual settings.

Specifications

- LCD-Display with key pad
- Automatic & semi-automatic operation mode
- Automatic dump system
- Integrated counter for operation hours
- Integrated counter for load cycles
- Maintenance intervals automatically displayed
- Required service part numbers automatically displayed
- Fully adjustable pressure ranges for start and stop
- Warning messages ("Housing Open" / "Emergency Switch")
- Check of end-pressure safety valve possible
- Auto switch-off when system is not running
- Extendable by additional modules (e.g. external filling panel)
- Easy to operate menu
- Door position switch (housing open message)
- Load-free or depressurised start cycles

Options

- Oil pressure control
- Oil temperature control
- Cylinder head temperature control
- Inter stage pressure monitoring
- PIN controlled access
- Master / slave option (if more than one ECC equipped compressors are combined)

DESCRIPTION

Switchboard



No.	Description
1	LCD Display
2	Key Pad
3	LED Display (Compressor OFF)
4	LED Display (Power)
5	LED Display (Compressor ON)



OPERATION AND FUNCTION

Main Menu

Immediately after the compressor has been connected to power, the ECC-display shows the following Main Menu::

Charging	0 min
Total	0,0 h
Start : 1	Stop : 0
Help: *	OFF
Final Press	0 bar

Present filling time in minutes

Total operation hours

Key 1 to start compressor / Key 0 to stop compressor

* Key leads to submenus Current operation state = Off

Present filling pressure

B

The following keys can now be used:

Key	Function / Description
1	Start - Starts the compressor
0	Stop - Stops the compressor
*	Leads to the submenus

After typing the * key the following Selection Menu appears.



OPERATION AND FUNCTION

Selection Menu (M100)

After typing the * key in the Main Menu the following Selection Menu appears.

Selection:		
2	Display	Key 2 leads to submenu "Display"
3	Settings	Key 3 leads to submenu "Settings"
4	Test	Key 4 leads to submenu "Test"
5	Statistics	Key 5 leads to submenu "Statistics"
6	Maintenance	Key 6 leads to submenu "Maintenance"
7	Operation Mode	Key 7 leads to submenu "Operation mode"
(M100)	Return : #	Key # leads back to "Main Menu"

(M100) tells that you are currently on menu page 100.



Note

At any time, the unit can be started with key 1 or shut down with key 0.
Caution: Risk of accident during maintenance work!

OPERATION AND FUNCTION

Display Menu (M200)

Pushing key 2 in the Selection Menu leads to Submenu "Display".

Display I:	
2	Press. Stage 1
3	Press. Stage 2
4	Press. Stage 3
5	Cyl. Head Temp.
6	Oil Temp.
7	Display II
(M200)	Return : #

Key 2 shows current pressure of the 1st stage*

Key 3 shows current pressure of the 2nd stage

Key 4 shows current pressure of the 3rd stage

Key 5 shows temperature of the final stage cylinder head

Key 6 shows the oil temperature

Key 7 shows Display II

Key # leads back to "Main Menu"

(M200) tells that you are currently on menu page 200.

By pushing key 2 (inter-stage pressure 1) the following Display appears.

Inter-Stage Pressure Display

Pushing key 2 in the Display Menu leads to the Inter-Stage Pressure 1 Display Menu.

Charging	0 min
Total	0,0 h
Start: 1	Stop: 0
Help:*	OFF
Press.	0 bar
1 st Stage	0,0 bar

Use keys 3 to 6 in the Menu "Display I" to change between the displayed values.



Note

Pushing key 8 in the display menu "Display II" leads to the option "Pressure200/300" for compressors with 2 filling pressures. Displayed in field 3 of the display menu "Display I".



OPERATION AND FUNCTION

Display II (M270)

Pushing key 7 in the Selection Menu leads to Menu "Display II".

Display II:

Press.	Temp.
4: 0	C: 0
5: 0	D: 0
6: 0	E: 0
7: 0	F: 0
bar	°C
(M270)	Return : #

This display shows further customer specific pressure and temperature values.

Key # leads back to "Main Menu"

B

OPERATION AND FUNCTION

Settings Menu (M300)

Pushing key 3 in the Selection Menu leads to the Settings Menu.

Settings:	
Automatic	
2	Stop pressure
3	Restart Press.
Semi-Automatic	
4	Stop Pressure
9	Close
(M300)	Return : #

Key 2 leads to submenu „Set Stop Pressure“

Key 3 leads to submenu „Set Restart Pressure“

Key 4 leads to submenu „Set Stop Pressure“

Key 9 leads back to submenu "Selection"

Key # leads back to "Main Menu"

B

Use menu M700 to change between "Automatic" and "Semi-Automatic" mode.

Restart pressure can only be set in "Automatic Mode".

Prior to setting the pressure, start the safety valve test.



Attention during maintenance

During automatic mode, the compressor can automatically start by itself at any time, depending on the selected restart pressure (see "Set Restart Pressure" M330).



OPERATION AND FUNCTION

Set Stop Pressure - automatic mode (M320)

Only valid in automatic mode, see menu M700.

Set
Stop Pressure:
Actual: 330 bar
7 New Value:
>> XXX bar
4 (050,, 333)
8 Confirm
(M320) Return : #

Current restart pressure
Key 7 if restart pressure should be changed
XXX indicates modified stop pressure
Chooseable pressure range for restart pressure
Key 8 confirms new restart pressure
Key # leads back to "Main Menu"

B

Set Restart Pressure - automatic mode (M330)

Only valid in automatic mode, see menu M700.

Set
Restart Pressure:
Actual: 180 bar
7 New Value:
>> XXX bar
4 (030,, 310)
8 Confirm
(M330) Return : #

Current restart pressure
Key 7 if restart pressure should be changed
XXX indicates modified restart pressure
Chooseable pressure range for restart pressure
Key 8 confirms new restart pressure
Key # leads back to "Main Menu"

Set Stop Pressure - semi-automatic mode (M340)

Only valid in semi-automatic mode, see menu M700.

Set
Stop Pressure:
Actual: 180 bar
7 New Value:
>> XXX bar
4 (030,, 310)
8 Confirm
(M340) Return : #

Current stop pressure
Key 7 if stop pressure should be changed
XXX indicates modified stop pressure
Chooseable pressure range for stop pressure
Key 8 confirms new restart pressure
Key # leads back to "Main Menu"

OPERATION AND FUNCTION

Test Menu (M400)

Pushing key 4 in the Selection Menu leads to the Test Menu.

Test:	
2	Solenoids
3	Safety Valve
4	Test-Stop
9	Close
(M400)	Return : #

Key 2 leads to submenu "Test Solenoids"

Key 3 leads to submenu "Test Safety Valve"

Key 4 leads to submenu "Test Stop without Venting"

Key 9 leads back to submenu "Selection"

Key # leads back to "Main Menu"

B

Test Solenoids (M420)

Pushing key 2 in the Selection Menu leads to Submenu "Test Solenoids".

Test Solenoids	
3	open
7	close
9	Close
(M420)	Return : #

Key 3 opens solenoids

Key 7 closes solenoids

Key 9 leads back to submenu „Test“

Key # leads back to "Main Menu"



Note

This menu can not be left unless solenoids have been closed by key 7.

OPERATION AND FUNCTION

Test safety valve (M430)

Pushing key 3 in the Test Menu leads to Submenu "Test Safety Valve".



Note

Prior to starting the Test, close all filling connections (also connected filling panels if necessary). During this test, the compressor passes the selected stop pressure (see Menu M320) to test the correct function of the final pressure safety valve. This would limit the maximum operating over pressure of the unit in case of malfunction.

B

Test

Safety Valve

Close Filling Valves!

5 Start	0 Stop
9 Close	
(M430) Return : #	

Key 5 to start test Key 0 to stop test

Key 9 leads back to submenu „Test“

Key # leads back to "Main Menu"

Test stop without venting (M440)

Pushing key 4 in the Test Menu leads to Menu "Test Stop without Venting".



Note

This test is only operable when the compressor has been started with key 1. This test mainly checks the leak tightness of pressure vessels, pressurised pipes, safety valves and the compressor block.

Test

stop without venting:

5 Stop	
6 Vent	
Pressure	0
	bar
9 Close	
(M440) Return : #	

Key 5 stops compressor during test run

Key 6 vents compressor after leak search has been finished

Shows current filling pressure

Key 9 leads back to submenu „Test“

Key # leads back to "Main Menu"



OPERATION AND FUNCTION

Statistics Menu (M500)

Pushing key 5 in the Selection Menu leads to Submenu "Statistics".

Statistics	
Operation Hours:	0,0 h
Start cycles:	00
Max Press	000 bar
9 Close	
(M500) Return : #	

Total operation hours of compressor unit

Total number of compressor starts

Maximum working pressure of unit (set by safety valve test)

Key 9 leads back to submenu „Selection“

Key # leads back to "Main Menu"

Push key 5 to get information on which ECC software version is currently installed on your system (M505), i.e.: By pushing key 2, the total load cycles of the filter housing are being indicated.

B

OPERATION AND FUNCTION

Maintenance Menu (M600)

Pushing key 6 in the Selection Menu leads to the "Maintenance Menu".

Hours remaining		
Oil change	14 h	Shows remaining hours of listed components (i.e. next oil change in 14 hours,...)
Sinter filt	989 h	
Silencer	4989 h	
Valves	5989 h	
Oil filter	1000 h	
8 Change done		Key 8 leads to submenu "Receipt Maintenance"
9 Close		Key 9 leads back to submenu „Selection“
(M600) Return : #		Key # leads back to "Main Menu"

Remaining hours depend on the type. At the end of any remaining hours, the display indicates a warning message. Furthermore, the display informs about any possibly necessary spare parts with the corresponding L&W service part number.



Attention during maintenance

During automatic mode, the compressor can automatically start by itself at any time, depending on the selected restart pressure (see "Set Restart Pressure" M330).



OPERATION AND FUNCTION

Confirm Maintenance (M680)

Confirm Maintenance	
2	Oil change
3	Sinter filters
4	Silencer
5	Valves
6	Oil filter
(M680)	Return : #

Key 2 receipts oil change
Key 3 receipts change of sinter filters
Key 4 receipts change of silencer
Key 5 receipts change of valves
Key 6 receipts oil filter
Key # leads back to "Main Menu"

B

Display confirms any reset of "Hours remaining" with the following message:

Confirm Maintenance	
Operation Hours Meter Set	
9	Close
(M680)	Return : #

Key 9 leads back to submenu "Hours remaining"
Key # leads back to "Main Menu"

OPERATION AND FUNCTION

Operation Mode (M700)

Pushing key 7 in the Selection Menu leads to the menu "Operation Mode".

Activated modes are always displayed in bolt letters (above example: **Semi-Automatic**).

Further settings can be made in the Settings Menu (M300).

B

Betriebsart:	
2	Automatic
3	Semi-Automatic
4	bar /mpa
5	Sprache
9	Close
(M700)	Return : #

Key 2 activates automatic mode

Key 3 activates semi-automatic mode

Key 4 selects between bar and MPa (optional)

Key 5 leads to the "Language Menu"

Key 9 leads back to submenu „Selection“

Key # leads back to "Main Menu"

Language Menu (M750)

Language Menu	
2	German
3	English
4	French
5	Spanish
6	Dutch
7	Language II
(M750)	Return : #

Key 7 optional language (e.g. Chinese)

Key # leads back to "Main Menu"

OPERATION AND FUNCTION

Adjusting Display Backlight

The brightness of the display can be adjusted with an adjusting screw on the back of the control.

Software Update

Software updates can only be carried out by L&W. To carry out an update, the device has to be send to the L&W service.

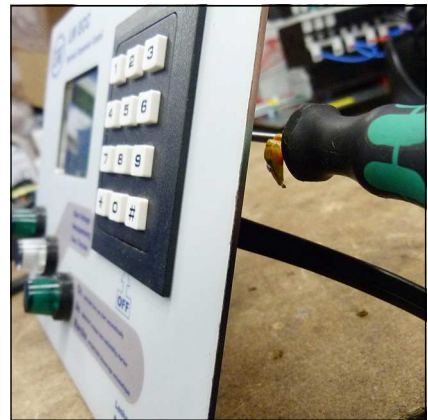

Adjust brightness

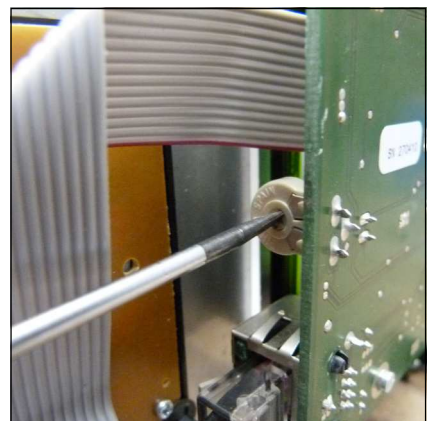

Adjust brightness

SPARE PART LISTS

Best.-Nr. / Order No.	Benennung	Description
002141	1. Stufe Druckaufnehmer 0-10 bar	1st stage pressure sensor 0-10 bar
002142	2. Stufe Druckaufnehmer 0-60 bar	2nd stage pressure sensor 0-60 bar
002143	Endstufe Druckaufnehmer 0-400 bar	Final stage pressure sensor 0-400 bar
006890	Druckaufnehmer 420 bar Version 0-600 bar	Pressure sensor 420 bar version 0-600 bar
004840	Öldruckaufnehmer 0-6 bar	Oil pressure sensor 0-6 bar
006912	Öltemperatursensor	Oil temperature sensor
003501	Zylinderkopf - Temperatursensor	Cylinderhead temperature sensor

B



002141 / 002142 / 002143 / 004840
Druckaufnehmer / Pressure sensor



006890 - Druckaufnehmer 420 bar /
Pressure sensor 420 bar



006912 - Öltemperatursensor
Oil temperature sensor



003501 - Zylinderkopf - Temperatursensor
Cylinderhead temperature sensor



LENHARDT & WAGNER GMBH

B

Manufacturer in terms of 97/23/EC

The full name and address of the manufacturer is:

Lenhardt & Wagner GmbH

An der Tuchbleiche 39
68623 Hüttenfeld / Germany

Phone: +49 (0) 62 56 - 85 88 0 - 0

Fax: +49 (0) 62 56 - 85 88 0 - 14

E-Mail: service@lw-compressors.com

Internet: www.lw-compressors.com





**ERSATZTEILLISTEN / SPARE PARTS LISTS
DETAILANSICHTEN / DETAILED VIEWS**

C



Inhaltsverzeichnis - Table of Contents

Gehäuse - Housing	1
Schalttafel - Control Board.....	3
Kompressorblock - Compressor Block	5
Öl+Wasserabscheider 1. Stufe - Oil+Water Separator 1st Stage.....	9
Öl+Wasserabscheider 2. Stufe - Oil+Water Separator 2nd Stage	11
Filtergehäuse 1,7 l - Filter Housing 1.7 ltr	13
Ansaugfilter - Air Intake Filter	15
Druckhalteventil - Pressure Maintaining Valve.....	17
Sicherheitsventil - Safety Valve	19
Motor	21
Ölpumpe - Oil Pump.....	23
Saug+Druckventil 1. Stufe - In+Outlet Valve 1st Stage.....	25
Saug+Druckventil 2. Stufe - In+Outlet Valve 2nd Stage	26
Saug+Druckventil 3. Stufe - In+Outlet Valve 3rd Stage	27
Kühler 1. Stufe - Cooler 1st Stage	28
Kühler 2. Stufe - Cooler 2nd Stage.....	30
Kühler 3. Stufe - Cooler 3rd Stage.....	32
Kolben 1. Stufe - Piston 1st Stage	34
Kolben 2. Stufe - Piston 2nd Stage.....	36
Kolben 3. Stufe - Piston 3rd Stage	38
Kurbelwelle - Crankshaft.....	40
Ölablassschlauch - Oil Drainage Tube	42
Füllschlauch - Filling Hose	44
Kreuzventil - Cross Design Valve	45



ERSATZTEILLISTE / SPARE PART LIST

Gehäuse / Housing

Best.-Nr. / Order No.	Benennung	Description
001041	Zylinderschraube M8x25mm DIN912 8.8 ZN	Allen Screw M8x25mm DIN912 8.8 ZN
001043	Zylinderschraube M8x35 DIN 912 8.8 ZN	Allen bolt M8x35 DIN 912 8.8 ZN
001159	Stopfmutter	Lock Nut M8 DIN 985 ZN
001181	U-Scheibe A8 DIN125 ZN	Washer A8 DIN125 ZN
001182	U-Scheibe A8 DIN9021 ZN	Washer A8 DIN9021 ZN
002081	Standfuss, PVC grün	Stand foot, PVC green
002720	Kompressorfuß mit Gummieinlage	Rubber Foot
006923	Grundkonsole LW 450 E Compact	Frame LW 450 E Compact
006924	Ventilatorschutz LW 450 E	Protective cover fan LW 450 E

C

DETAILANSICHT / DETAILED VIEW

Gehäuse / Housing

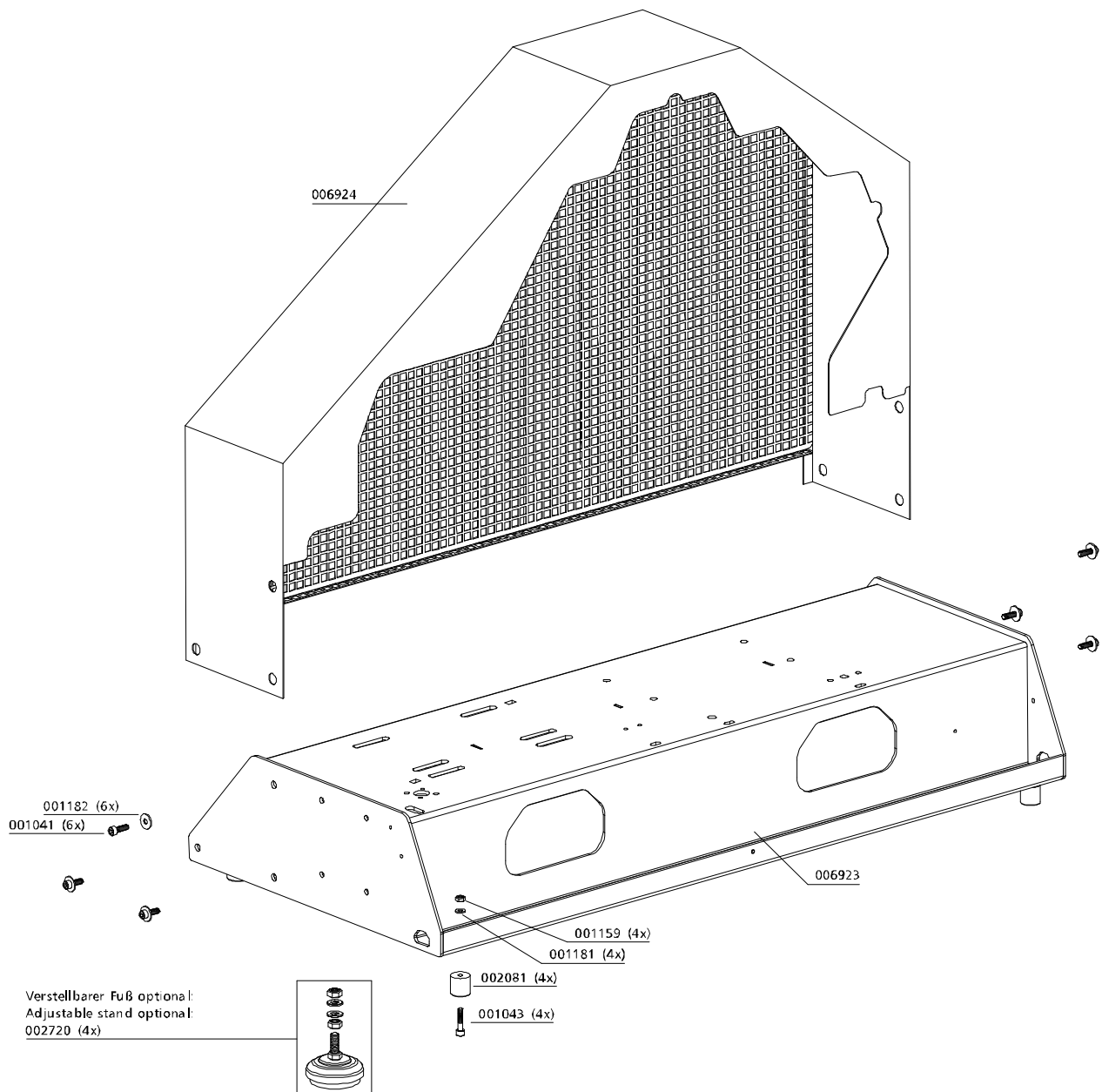

C



ERSATZTEILLISTE / SPARE PART LIST

Baugruppe: Schalttafel / Control Board

Best.-Nr. / Order No.	Benennung	Description
002089	Betriebsstunderzähler 230V	Hour Counter 230V
002942	Start/Stop Schaltelement	Start / Stop Button
003121	Not-Halt Schalter	Emergency switch
004701	Warnlampe	Warning lamp
006859	Schildträger	Label holder
006925	Einlegeschild	Label

C

DETAILANSICHT / DETAILED VIEW

Baugruppe: Schalttafel / Control Board

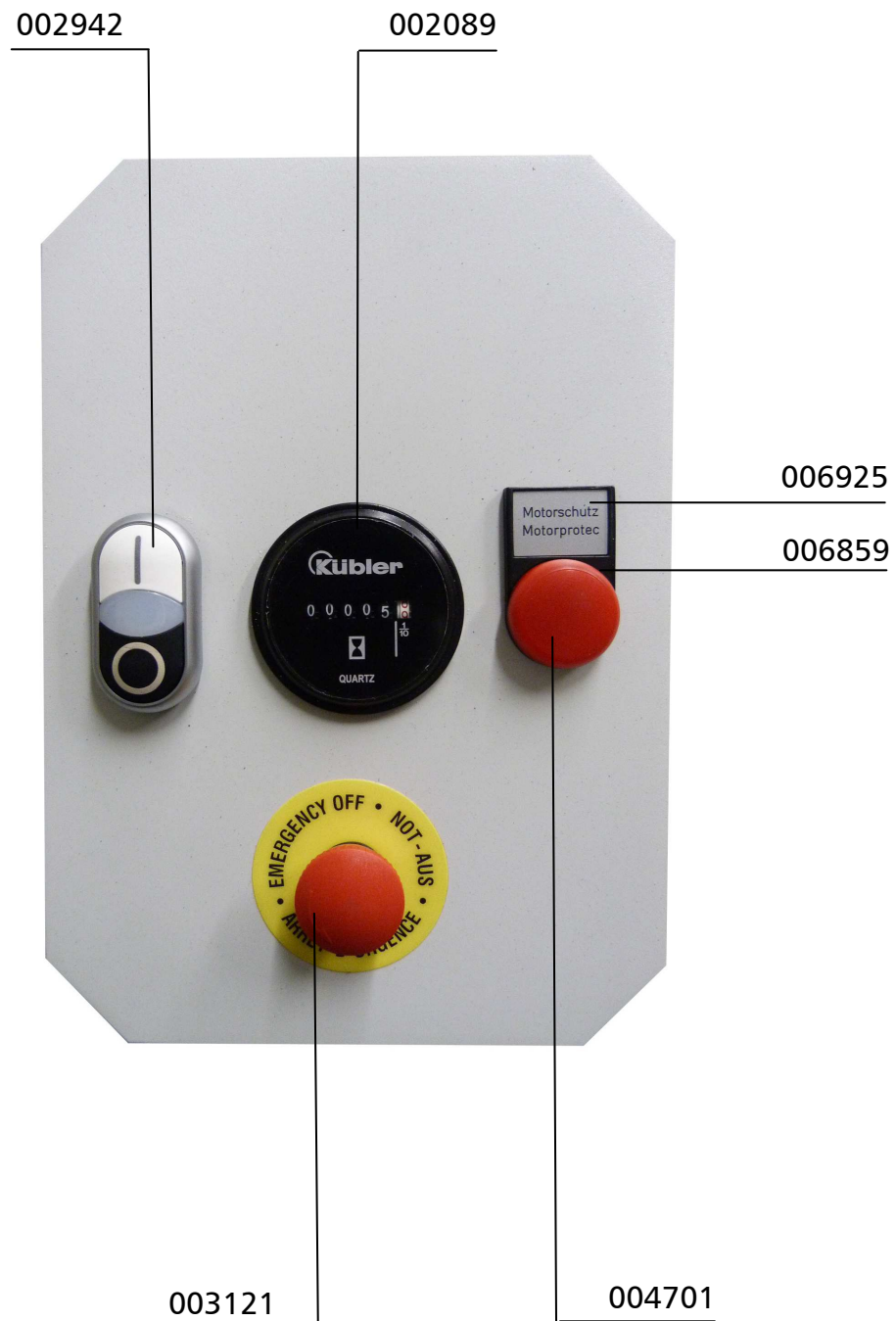

C



ERSATZTEILLISTE / SPARE PART LIST

Baugruppe: Kompressorblock / Assembly: Compressor Block

Best.-Nr. / Order No.	Benennung	Description
000180	Ölschlauchstutzen	Oil hose clip
000209	Öleinfüllstopfen	Oil Filler Plug
000220	Sicherheitsventil G3/8", 8bar	Safety valve G3/8", 8bar
000225	Sicherheitsventil G3/8", 50bar	Safety valve G3/8", 50bar
000239	Kugellager 450/570, 6308 C3	Ball Bearing 6308 C3
000240	Dichtung Zylinderflansch / Block	Paper Gasket Cylinder Flange
000241	Dichtung Lagerflansch	Gasket bearing flange
000243	Lagerring	Bearing bush
000244	Wellendichtung 40x72x10mm	Shaft Seal 40x72x10mm
000250	CU-Ring Ø6,2 x 10 x 1,5mm DIN7603A	Copper Washer Ø6,2 x 10 x 1,5mm DIN7603A
000253	Untere Ventildichtung 2.Stufe	Lower valve gasket 2nd stage
000254	Obere Ventildichtung 2.Stufe	Upper valve gasket 2nd stage
000257	Obere Ventildichtung 1.Stufe	Upper valve gasket 1 st stage
000258	Untere Ventildichtung 1.Stufe, Kupfer	Lower valve gasket 1 st stage, copper
000270	Ventilkopf 2.Stufe	Valve head 2nd stage
000271	Ventilkopf 1.Stufe	Valve head 1st stage
000273	Lagerdeckel	Main Bearing Flange
000274	Zylinder Æ42mm	Cylinder Æ42mm
000711	Verschraubung GE 06L R1/8"	Connection GE 06L R1/8"
000738	Verschraubung GE 08 PLR 1/4"	Connection GE 08 PLR 1/4"
000761	Verschraubung WE 08 PLR CFX 1/4"	Elbow Connection WE 08 PLR CFX 1/4"
000765	Schneidring 8mm PSR 08 LX	Olive Seal PSR 08 LX
000767	Mutter 08 S M16x1,5 IG	Union Nut 08 S M16x1,5 IG
000818	Verschraubung GE 15L R1/2"	Connection GE 15L R1/2"
000863	Verschraubung WE 18L R A3C	Elbow Connection WE 18L R A3C
000919	Reduzierung RI3/4X1/2CFX	Reducer RI3/4X1/2CFX
000951	Sechskantschraube M6x16 DIN 933 8.8	Hexagon screw M6x16 DIN 933 8.8
000961	Stiftschraube M8x25mm DIN939	Threaded Stud M8x25mm DIN939
001056	Zylinderschraube M8x60 DIN 912 8.8 ZN	Allen bolt M8x60 DIN 912 8.8 ZN
001058	Zylinderschraube M8x70 DIN 912 8.8 ZN	Allen bolt M8x70 DIN 912 8.8 ZN



ERSATZTEILLISTE / SPARE PART LIST

Baugruppe: Kompressorblock / Assembly: Compressor Block

Best.-Nr. / Order No.	Benennung	Description
001060	Zylinderschraube M8x80 DIN 912 8.8 ZN	Allen bolt M8x80 DIN 912 8.8 ZN
001088	Zylinderschraube M10x60 DIN 912 8.8 ZN	Allen bolt M10x60 DIN 912 8.8 ZN
001100	Sechskantschraube M10x25 DIN 933 8.8 ZN	Hexagon screw M10x25 DIN 933 8.8 ZN
001101	Sechskantschraube M10x35 DIN933 8.8 ZN	Hexagon Screw M10x35 DIN933 8.8 ZN
001104	Sechskantschraube M10x50 DIN933 8.8 ZN	Hexagon screw M10x50 DIN933 8.8 ZN
001158	Mutter M8 DIN 934 ZN	Nut M8 DIN 934 ZN
001163	Mutter M10 DIN 934 ZN	Nut M10 DIN 934 ZN
001181	U-Scheibe A8 DIN 125 ZN	Washer A8 DIN 125 ZN
001188	U-Scheibe A10 DIN 125 ZN	Washer A10 DIN 125 ZN
001271	O-Ring 47x2,5 NBR 70, bis 04/2012	O-Ring 47x2.5 NBR 70, up to 04/2012
001274	O-Ring 50 x 2,5 NBR70, ab 05/2012	O-Ring 50 x 2,5 NBR70, since 05/2012
001323	Kupferring Ø10x16x2 DIN7603A	Copper seal ring Ø10x16x2 DIN7603A
001346	Sicherungsring, A40 DIN471	Circlip, A40 DIN471
001426	Führungszylinder Æ42mm	Guide Zylinder Æ42mm
001828	U-Scheibe A10 DIN 6340 ZN	Washer A10 DIN6340 ZN
002111	Zylinder Æ95, 1.Stufe	Cylinder 1st stage
002358	Schnellkupplung gerade G1/8"- 6mm	Quick Release Coupling G1/8"- 6mm
002367	Ventilkopf 3.Stufe	Valve head 3rd stage
002478	Zylinder 3.Stufe, Æ18	Cylinder 3rd stage
002991	Kurbelgehäuse mit Bleibronze Lagerbuchse	Bearing sleeve in leaded bronze
003184	Oeldruckleitung kompl.	Oil pressure pipe compl.
003187	Halteblech Öleinfüllschlauch, Aluminium	Bracket oil filter hose, alloy
003188	Öleinfüllschlauch Ø18	Oil filler hose Ø18
003189	Schlauchschele	Hose Clip
003190	Entlüftungsschlauch	Ventilation Hose
003191	Öleinfüllstopfen	Oil filter plug
003286	Ölschauglas	Oil gauge glass
003766	Aludichtring für G3/8"	Alloy Seal Ring for G3/8"
004749	PG Schlauchdurchführung, PVC	PVC hose c/W connection



ERSATZTEILLISTE / SPARE PART LIST

Baugruppe: Kompressorblock / Assembly: Compressor Block

Best.-Nr. / Order No.	Benennung	Description
	BG Kurbelwelle	Ass: Crankshaft
	BG: Ventil 1.Stufe	Ass: Valve 1 st stage
	BG: Ventil 2.Stufe	ASS: Valve 2nd stage
	BG: Ventil 3.Stufe	ASS: Valve 3rd stage
	BG: Kolben 1.Stufe	Ass: Piston 1 st stage
	BG: Kolben 2.Stufe	ASS: Piston 2nd stage
	BG: Kolben 3.Stufe	ASS: Piston 3rd stage

C



ERSATZTEILLISTE / SPARE PART LIST

Öl- und Wasserabscheider 1. Stufe / Oil- and Water Separator 1st Stage

Best.-Nr. / Order No.	Benennung	Description
000175	Deckel, Wasserabscheider	Cover Water Separator
000183	Wasserabweiser	Filter Protector
000184	Sinterfilter Wasserabscheider	Sintered Filter, Oil Filter
000185	Halteteller	Plate
000186	Drallscheibe	Twist Disk
000187	Stiftschraube	Threaded Stud
000563	Wasserabscheider - Behälter	Container Water Separator
000820	Verschraubung WE 15L RX	Ellbow Connection
000822	Mutter 15L	Nut 15L
000823	Schneidring PSR 15 LX	Olive Seal 15mm
000861	Schneidring PSR 18 LX	Olive Seal 18mm
000862	Mutter M18L	Nut 18L
000863	Verschraubung WE 18L	Elbow Connection
001040	Zylinderschraube M8x20mm	Allen Screw M8x20mm DIN912 8.8 ZN
001181	U-Scheibe A8 DIN125 ZN	Washer A8
001294	O-Ring 68x3 NBR90	O-Ring 68x3
001431	Befestigungsring Wasserabscheider LW 450	Lock Ring Water Separator
002563	Wasserabscheider Oberteil	Water Separator Top
003077	Entwässerungsventil G1/4" AG	Drain valve G1/4" male
006845	Stopfmutter, Edelstahl, M6 DIN985	Lock Nut, s/s, M6 DIN985

C

DETAILANSICHT / DETAILED VIEW

Öl- und Wasserabscheider 1. Stufe / Oil- and Water Separator 1st Stage

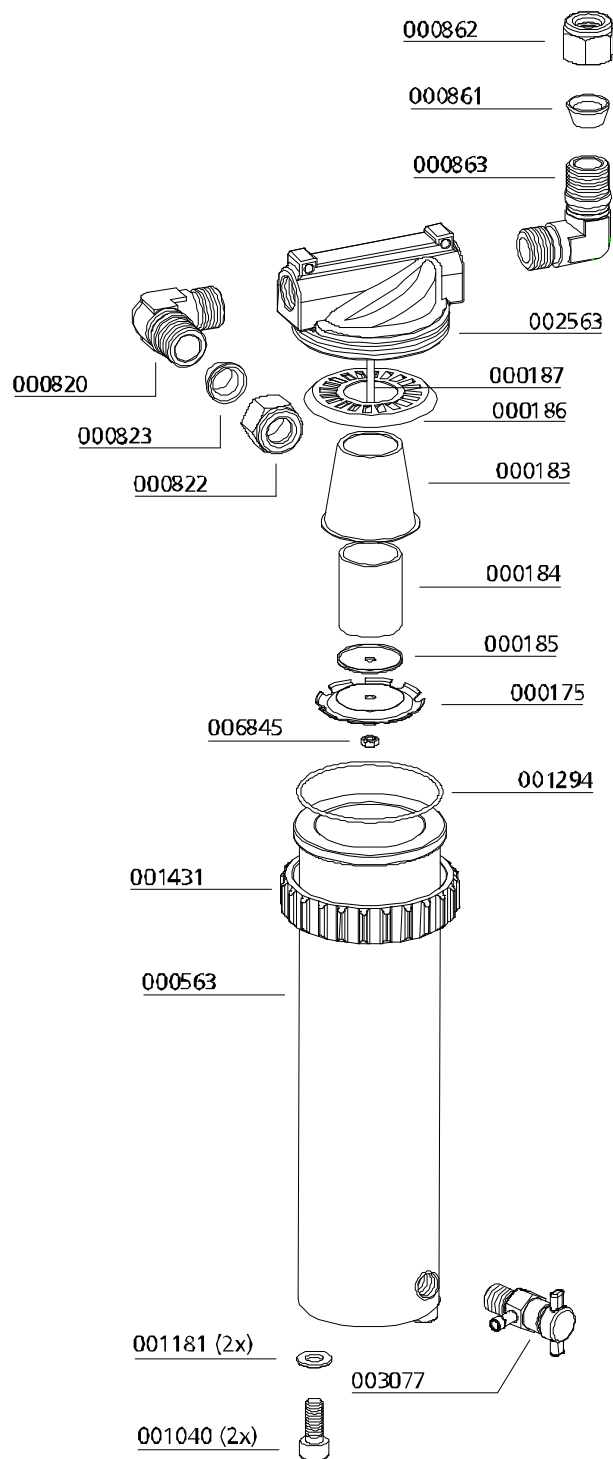

C



ERSATZTEILLISTE / SPARE PART LIST

Öl- / Wasserabscheider 2. Stufe / Oil- / Water Separator 2nd Stage

Best.-Nr. / Order No.	Benennung	Description
000172	Halteteller Wasserabscheider	Plastic Air Deflector
000173	Sinterfilter Wasserabscheider	Sintered Filter
000174	Drallscheibe, Wasserabscheider	Twist Disk
000176	Stiftschraube, Wasserabscheider	Treaded Stud
000177	Wasserabweiser, Wasserabscheider	Water Deflector, Plastic
000379	Wasserabscheider - Oberteil	Top ap Water Separator
000562	Wasserabscheider - Ring	Ring Water Separator
000564	Wasserabscheider – Behälter 2.Stufe LW450	Container Water Separator
000733	Schneidring SR06	Olive seal SR06
000758	Verschraubung T 1/4" seitlich	T-connection with 1/4" radial
000766	Mutter L08	Nut L08
000837	Verschlussstopfen, VSTI R1/4"ED CFX	Plug
000839	Verschlussstopfen, VSTI R3/8"ED CFX	Plug
000863	Verschraubung	Elbow Connection
000892	Doppelnippel	Double nibble
000921	Reduzierung R1/2X1/4CFX	Reducer R1/2X1/4CFX
001099	6-kant Schraube	Hexagon Screw
001190	Federring A10	Spring Washer A10
001272	O-Ring Wasserabscheider 47x3 NBR70	O-Ring 47x3
003077	Entwässerungsventil G1/4" AG	Drain valve G1/4" male
006845	Stopfmutter, Edelstahl, M6 DIN985	Lock Nut, s/s, M6 DIN985

DETAILANSICHT / DETAILED VIEW

Öl- / Wasserabscheider 2. Stufe / Oil- / Water Separator 2nd Stage

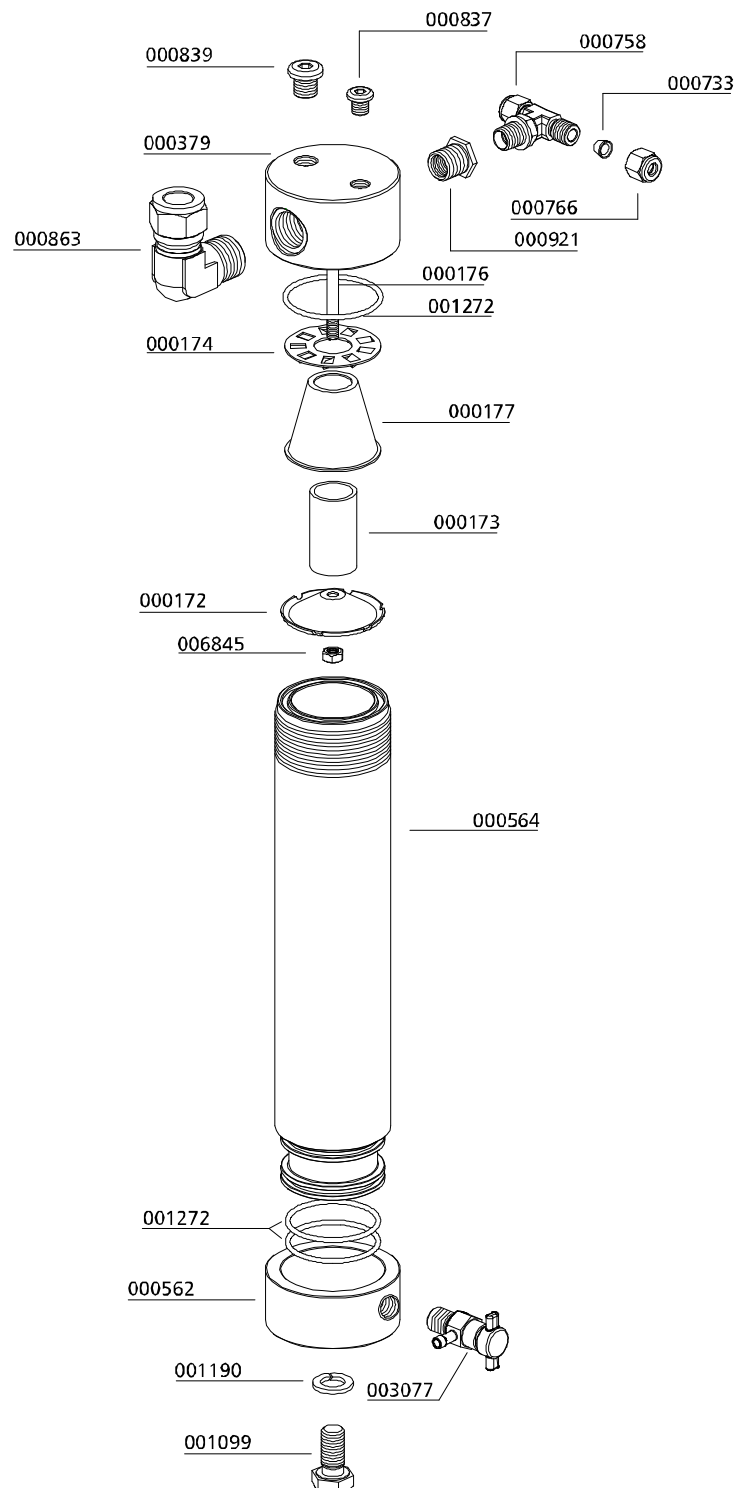

C

Filtergehäuse 1,7 l / Filter Housing 1.7 ltr

Best.-Nr. / Order No.	Benennung	Description
000002	Filterpatrone 1,7l	Filter Cartridge 1.7ltr
000272	Abstandshalter für Filtergehäuse	Spacer Bracket for Filtertower
000383	Messing Adapter für Filterpatrone	Brass Filter Adapter
000384	Düse Filtergehäuse	Jet Filter Housing
000738	Verschraubung GE08LRFCX	Connection GE08LRFCX
000761	Verschraubung WE08LRFCX	Elbow Connection WE08LRFCX
000765	Schneidring PSR 08 LX	Olive Seal PSR 08 LX
000766	Mutter M08LCFX	Union Nut M08LCFX
001160	Hutmutter M8 DIN1587 ZN	Domed Nut M8 DIN1587 ZN
001181	U-Scheibe A8 DIN125 ZN	Washer A8 DIN125 ZN
001184	Schnorr-Scheibe S8 N0110 ZN	Clamp Washer S8 N0110 ZN
001285	Stützring, Filtergehäuse	Back-up Ring Filter Housing
001287	O-Ring, Filtergehäuse	O-Ring filter housing
002140	Filterschlüssel 1,7 & 2,3 Liter Behälter	Filter tool 1,7 & 2,3 Litre
002147	Haltebügel für Filtergehäuse, beidseitig M8X35mm	Holder for filter housing, M8X35mm (both sides)
002366	Filtergehäuse, 1,7l	Filter housing 1.7ltr
003077	Entwässerungsventil G1/4"	Drain valve G1/4"
005244	O-Ring 16x2,5 NBR90	O-Ring 16x2,5 NBR90

DETAILANSICHT / DETAILED VIEW

Filtergehäuse 1,7 l / Filter Housing 1.7 ltr

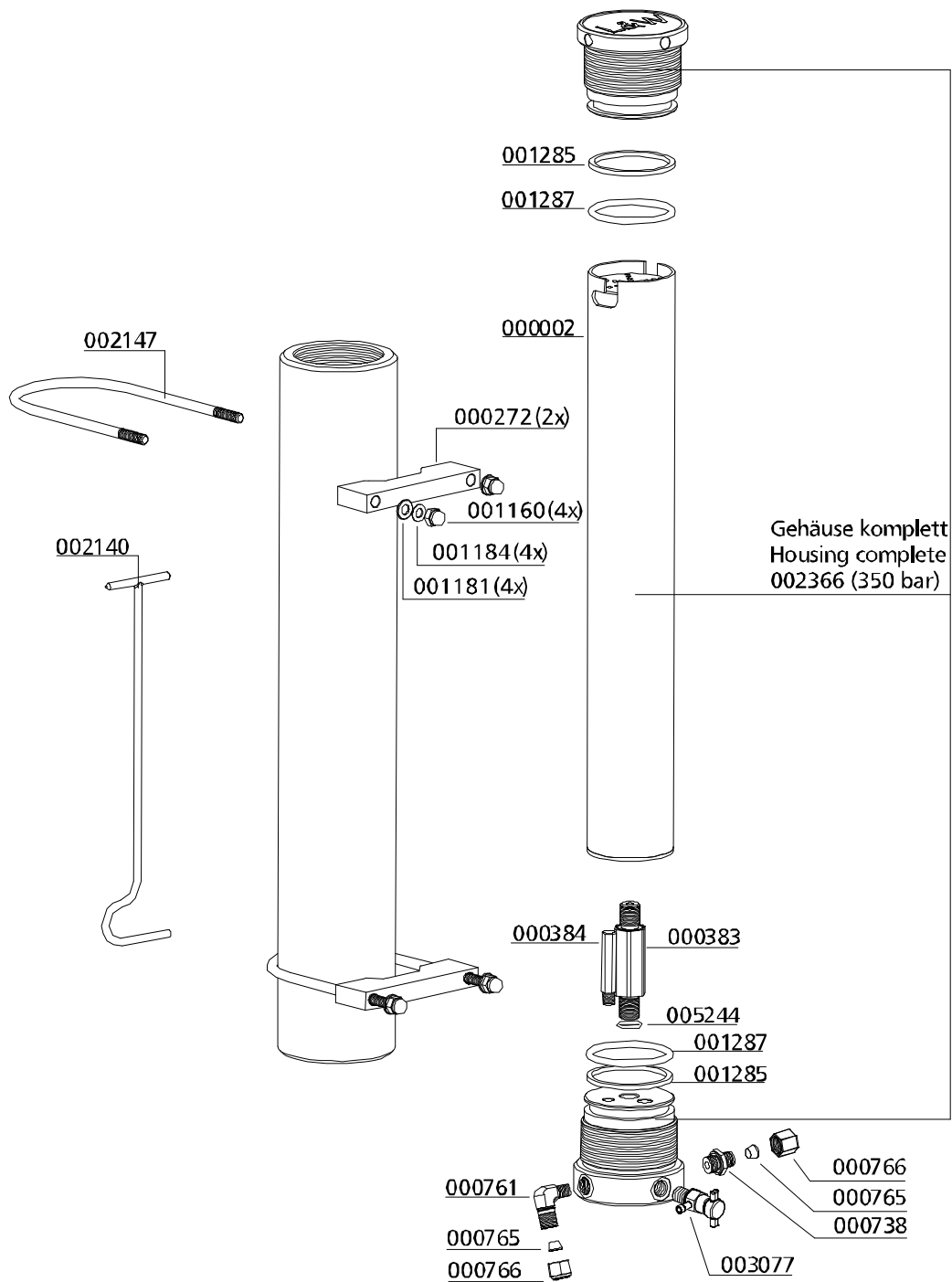

C



ERSATZTEILLISTE / SPARE PART LIST

Baugruppe: Ansaugfilter / Intake Filter

Best.-Nr. / Order No.	Benennung	Description
000170	Ansaugfilterpatrone	Air Intake Filter Cartridge
000171	Ansaugfiltergehäuse inkl. Patrone, kompl	Int. Filter Housing c/w filter
000201	Einschraubadapter Ansaugfilter	Adapter Inlet Filter Housing

C

DETAILANSICHT / DETAILED VIEW

Baugruppe: Ansaugfilter / Intake Filter

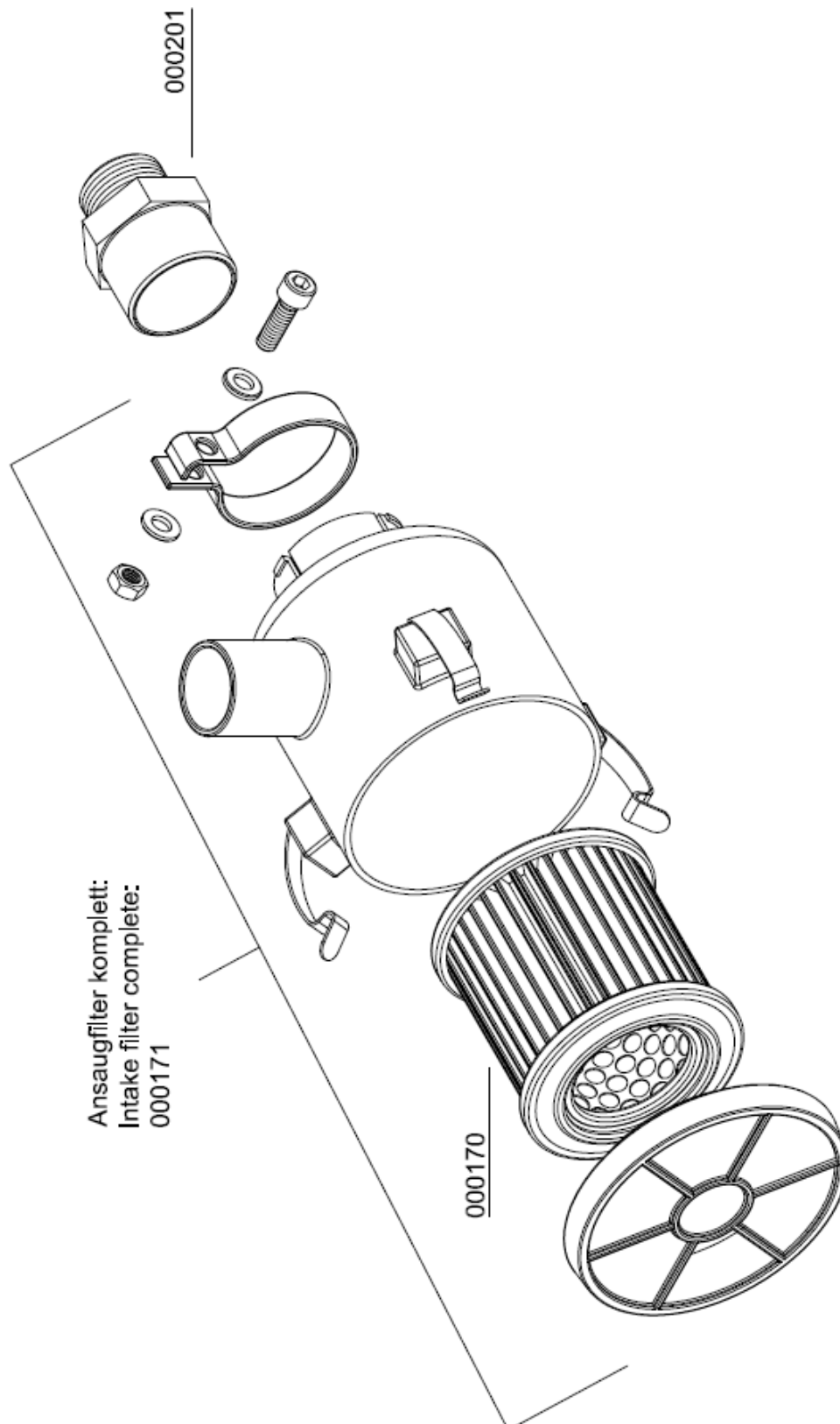

C



ERSATZTEILLISTE / SPARE PART LIST

Druckhalteventil / Pressure Maintaining Valve

Best.-Nr. / Order No.	Benennung	Description
000169	Druckhalterückschlagventil, schwarz	Pressure Maint. Valve black
000498	U-Scheibe DIN 125 A6	Washer DIN 125 A6
000506	Feder	Spring
000508	USIT Ring 13,7 x Ø20 x 1,5	Gasket Ring U-Sit 13,7 x Ø20 x 1,5
000511	Mutter, Druckhalterückschlagventil	Lock Nut PMV
000512	Schraube, Druckhalte-Rückschlagventil	Set Bolt PMV
000513	Druckstück für Druckhalteventil,	Spring Adapter PMV, spring adapter
000514	Stift Druckhalte-/Rückschlagventil	Stud PMV
000515	Gehäuse, Druckhalte-Rückschlagventil	Main Body PMV
000516	Nutring, Druckhalterückschlagventil 5 x 10 x 5/2,5 90° Blau	Seal Ring PMV 5 x 10 x 5/2,5 90° blue
000517	Feder, Druckhalterückschlagventil	Coil Spring PMV
000518	Unterlegscheibe, Messing	Washer, Brass
000519	Dichtkappe, Druckhalte Rückschlagventil, schwarz	Plastic Seal Piston PMV, black
000520	Hohlschraube, DHRV	Inlet Jet PMV
000765	Schneidring PSR 08 LX	Olive Seal PSR 08 LX
000767	Mutter 08 S	Union Nut 08 S
001023	Zylinderschraube	Allen Bolt

DETAILANSICHT / DETAILED VIEW

Druckhalteventil / Pressure Maintaining Valve

**Reparatursatz
003548:**

Bestehend aus:
Gelbmarkierte
Bestellnummern

**Repair kit
003548:**

Consists of:
Yellow marked
P/N's

000169 (complete)

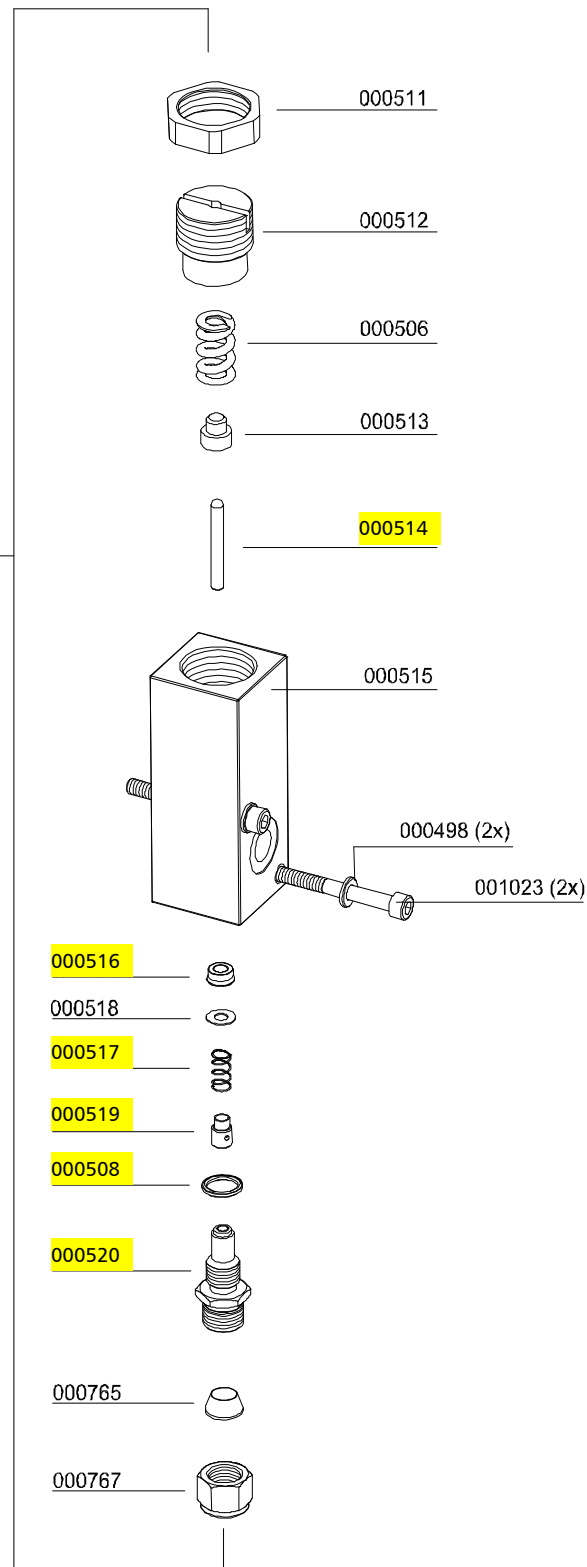

C



ERSATZTEILLISTE / SPARE PART LIST

Sicherheitsventil / Safety Valve

Best.-Nr. / Order No.	Benennung	Description
000233	Sockel für Sicherheitsventil mit TÜV, x G1/4" seitlich 180°	Base for Safety Valve TÜV type
000553	Sicherheitsventil 225bar mit TÜV	Safety Valve 225bar c/w TÜV
000554	Sicherheitsventil 250bar mit TÜV	Safety Valve 250bar c/w TÜV
000555	Sicherheitsventil 300bar mit TÜV	Safety Valve 300bar c/w TÜV
000556	Sicherheitsventil 330bar mit TÜV	Safety Valve 330bar c/w TÜV
000557	Sicherheitsventil 350bar mit TÜV	Safety Valve 350bar c/w TÜV
000738	Verschraubung GE08LRCFX	Connection GE08LRCFX
000765	Schneidring PSR 08 LX	Olive Seal PSR 08 LX
000766	Mutter M08LCFX	Nut M08LCFX
000838	Verschlussstopfen VSTIR1/4EDCF	Plug VSTIR1/4EDCF
001044	Zylinderschraube	Allen Bolt
001058	Zylinderschraube	Allen Bolt
001158	Mutter	Nut
001181	U-Scheibe	Washer
001244	O-Ring, Flansch Sicherheitsventil	O-Ring, Flange Safety Valve
001814	Sicherheitsventil 225bar mit CE	Safety Valve 225bar with CE
001815	Sicherheitsventil 250bar mit CE	Safety Valve 250bar with CE
001816	Sicherheitsventil 330bar mit CE	Safety Valve 330bar with CE
001817	Sicherheitsventil 350bar mit CE	Safety Valve 350bar with CE

C

DETAILANSICHT / DETAILED VIEW

Sicherheitsventil / Safety Valve

Druck/ Pressure	SV-Ventil mit CE-Prüfung/ Safety Valve with CE	SV-Ventil mit TÜV-Prüfung/ Safety Valve with TÜV
225 bar	001814	000553
250 bar	001815	000554
285/300 bar	-----	000555
330 bar	001816	000556
350 bar	001817	000557

Sonder-Einstelldrücke auf Anfrage! /
Special relieve pressures are available on request!

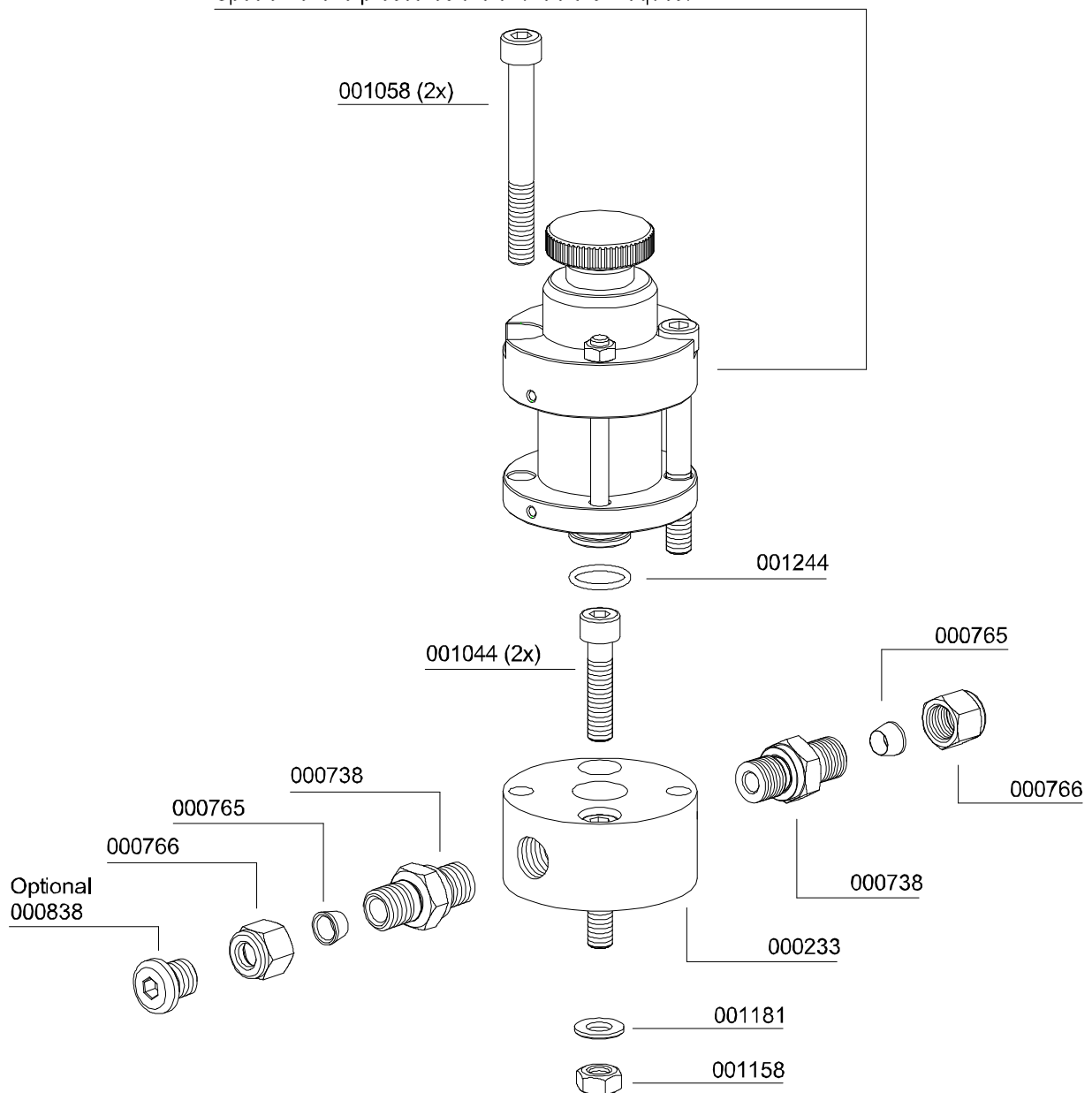



ERSATZTEILLISTE / SPARE PART LIST

Motor / Motor

Best.-Nr. / Order No.	Benennung	Description
001133	Sechskantschraube	Hexagon Bolt
001165	Mutter M12	Nut M12
001191	U-Scheibe A12	Washer A12
001192	Federring A12	Spring Washer A12
001409	Keilriemen	V-Belt
001453	Keilriemen	V-Belt
002872	Antriebsmotor 11 kW 230 V 50/60 Hz	Drive motor 11kW 230V(50/60Hz)
002974	Antriebsmotor 11 kW / 400V 50/60Hz	Drive Motor 11kW 400V 50/60Hz
002975	Riemenscheibe, kompl. mit Buchse	Pulley, c/w hub
003172	Schwungrad / Lüfterrad	Flywheel
003175	Passfeder (Motor) LW 300/450	Woodruff Key (motor)
004291	Antriebsmotor 7,5 kW / 400 V - 50/60 Hz	Motor 7,5kW, 400V, 50/60Hz
004395	Antriebsmotor 7,5kW / 230V / 50/60 Hz	Motor, 7,5kW, 230V, 50/60 Hz
005122	U-Scheibe Kurbelwelle	Washer, crank shaft
005207	Riemenscheibe, inkl. Spannbuchse	Pulley c/w taper bush

C

DETAILANSICHT / DETAILED VIEW

Motor / Motor

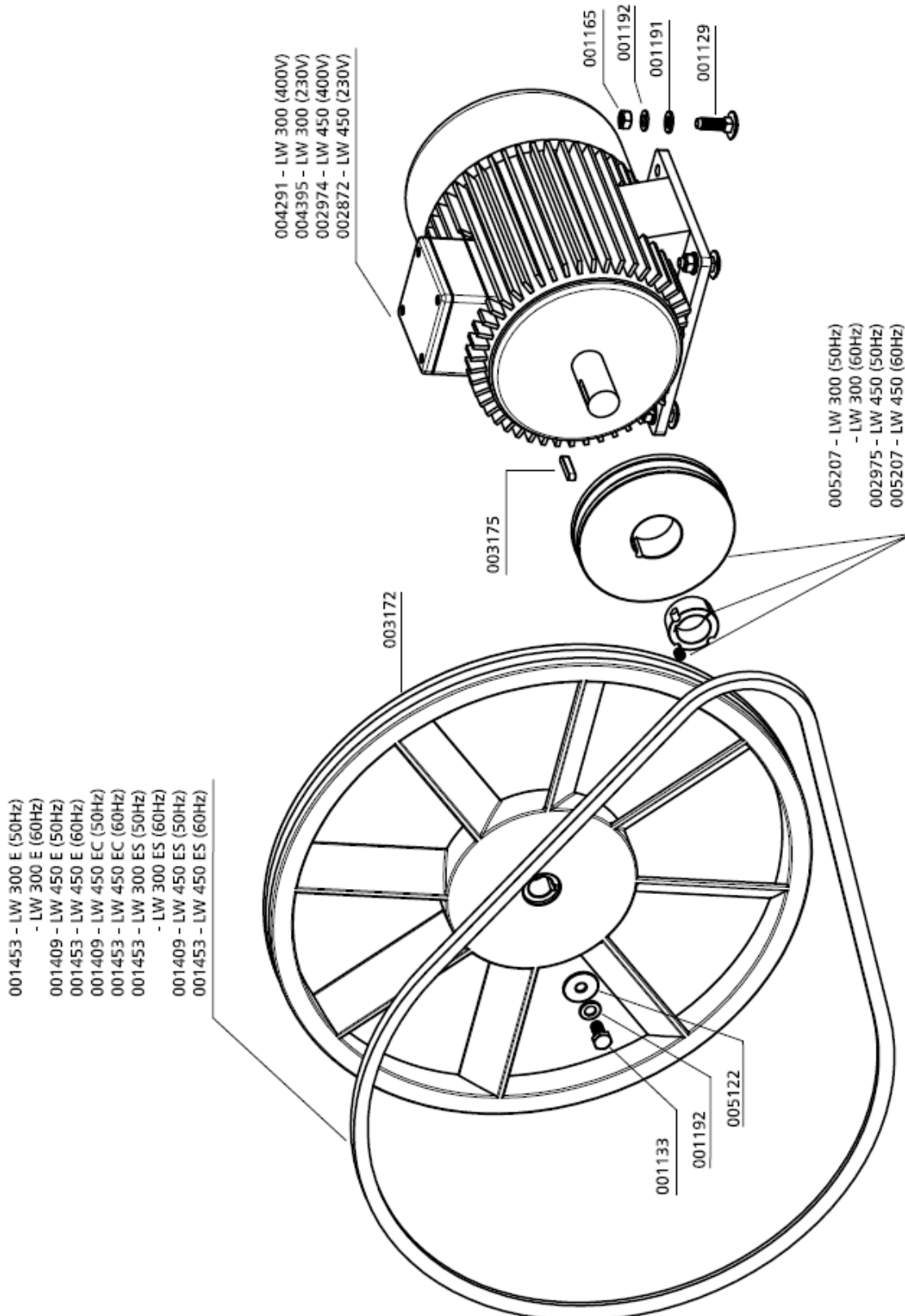

C



ERSATZTEILLISTE / SPARE PART LIST

Ölpumpe / Oil Pump

Best.-Nr. / Order No.	Benennung	Description
000200	Ölpumpenhalteflansch	Adapter Flange Oil Pump
000204	Ölpumpe, kompl.	Oil Pump compl.
000208	Ölpumpenantriebsflansch	Drive Flange Oil Pump
000250	CU-Ring Ø6,2 x 10 x 1,5mm DIN7603A	Copper Washer Ø6,2 x 10 x 1,5mm DIN7603A
000376	Ölansaugschlauch	Oil Hose
000710	Verschraubung GE06LRFCX	Connection GE06LRFCX
000952	Sechskantschraube M6X20mm, DIN933, 8.8	Hexagon Bolt M6X20mm DIN933, 8.8
000958	Gewindestift M8x16mm DIN914, 5.8 ZN	Worm Screw M8x16mm DIN914 5.8 ZN
001014	Gewindestift mit Zapfen M6X14mm DIN915	Allen Screw with Pin M6X14mm DIN915
001323	CU-Ring, Ø10 x 16 x 2mm, DIN7603A	Copper Seal Ring, Ø10 x 16 x 2mm, DIN7603A
001324	CU-Ring, Ø10,4 X 13,4 X 1mm, DIN7603A	Copper Seal Ring, Ø10,4 X 13,4 X 1mm,
001327	CU-Ring,m Ø 13 x 18 x 1,5mm DIN7603A	Copper Seal Ring, Ø 13 x 18 x 1,5mm
001329	CU-Ring, Ø14,5 X 20 X 1,5mm, DIN7603A	Copper Seal Ring, Ø14,5 X 20 X 1,5mm,
002340	O-Ring Ölpumpenflansch 32,2x3 NBR70	O-Ring, oil pump flange 32,2x3 NBR70
005271	Hohlschraube Ölansaugschlauch G1/8"	Banjo Bolt oil intake hose G1/8"
005272	Hohlschraube Ölansaugschlauch G1/4"	Banjo Bolt oil intake hose G1/4"

DETAILANSICHT / DETAILED VIEW

Ölpumpe / Oil Pump

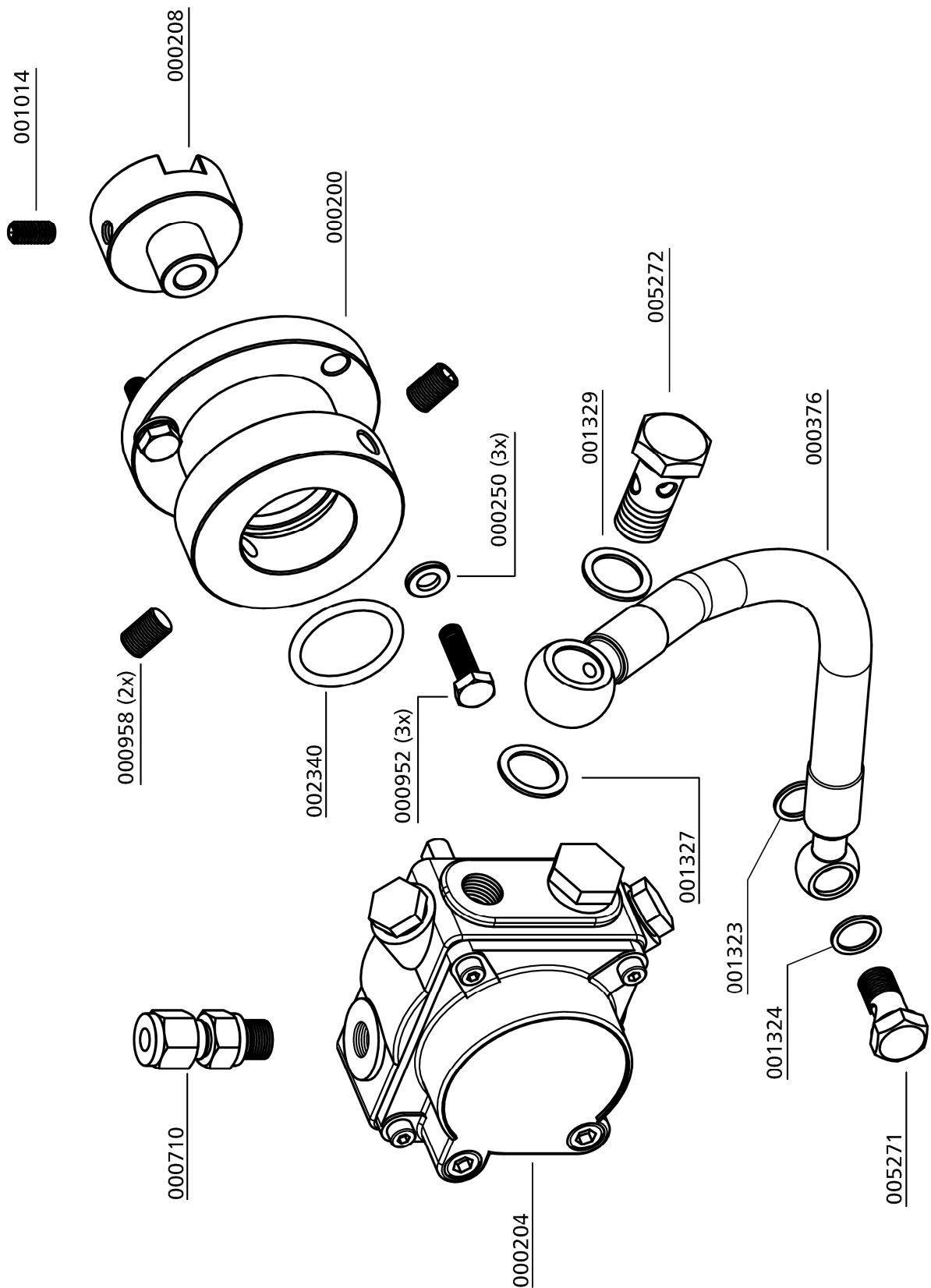

ERSATZTEILLISTE / SPARE PART LIST

Saug- und Druckventil 1. Stufe / In- and Outlet Valve 1st Stage

Best.-Nr. / Order No.	Benennung	Description
000259	Saug- Druckventil, 1. Stufe	In-&Outlet Valve, 1st Stage

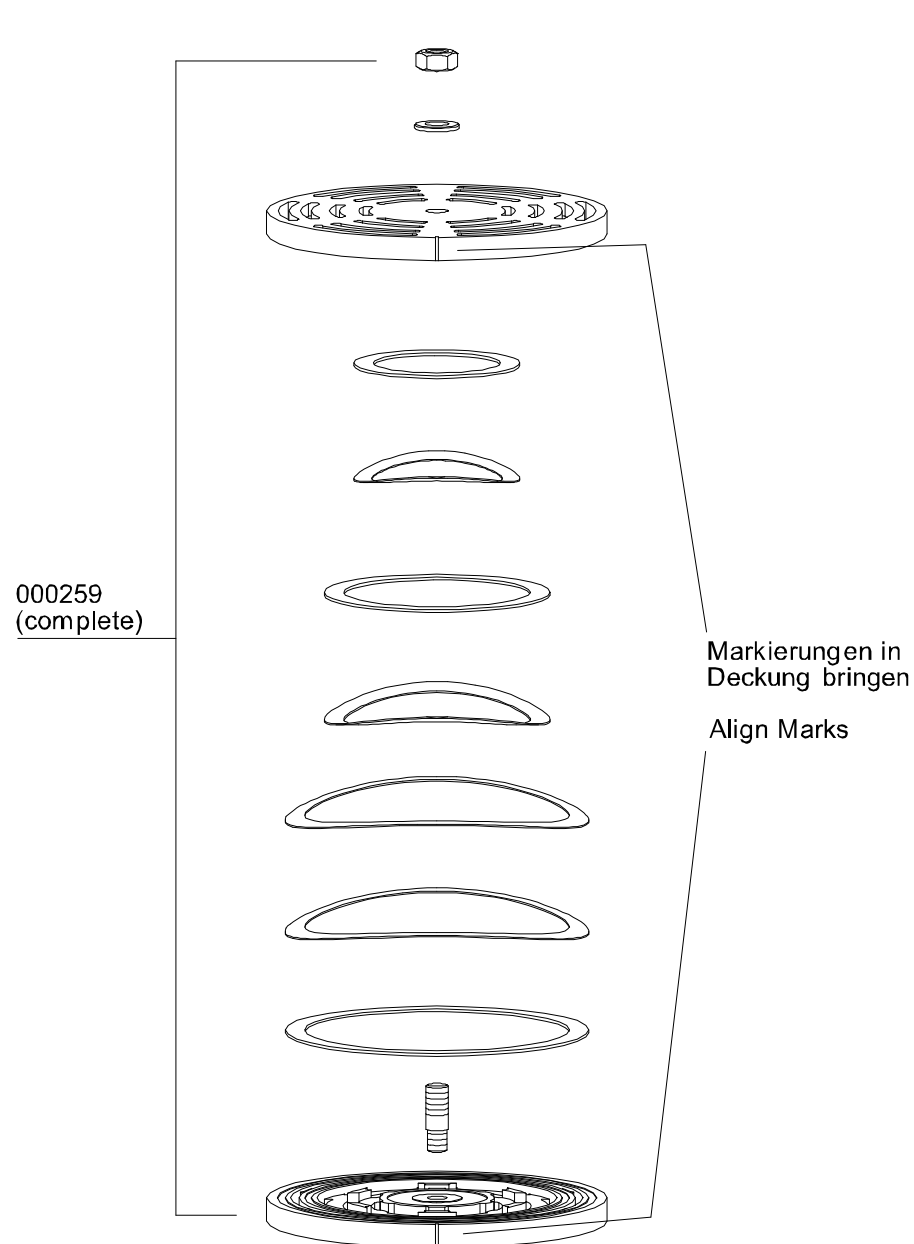

ERSATZTEILLISTE / SPARE PART LIST

Saug- und Druckventil 2. Stufe / In- and Outlet Valve 2nd Stage

Best.-Nr. / Order No.	Benennung	Description
000256	Saug- und Druckventil 2. Stufe	In- & Outlet Valve comp.2nd Stage

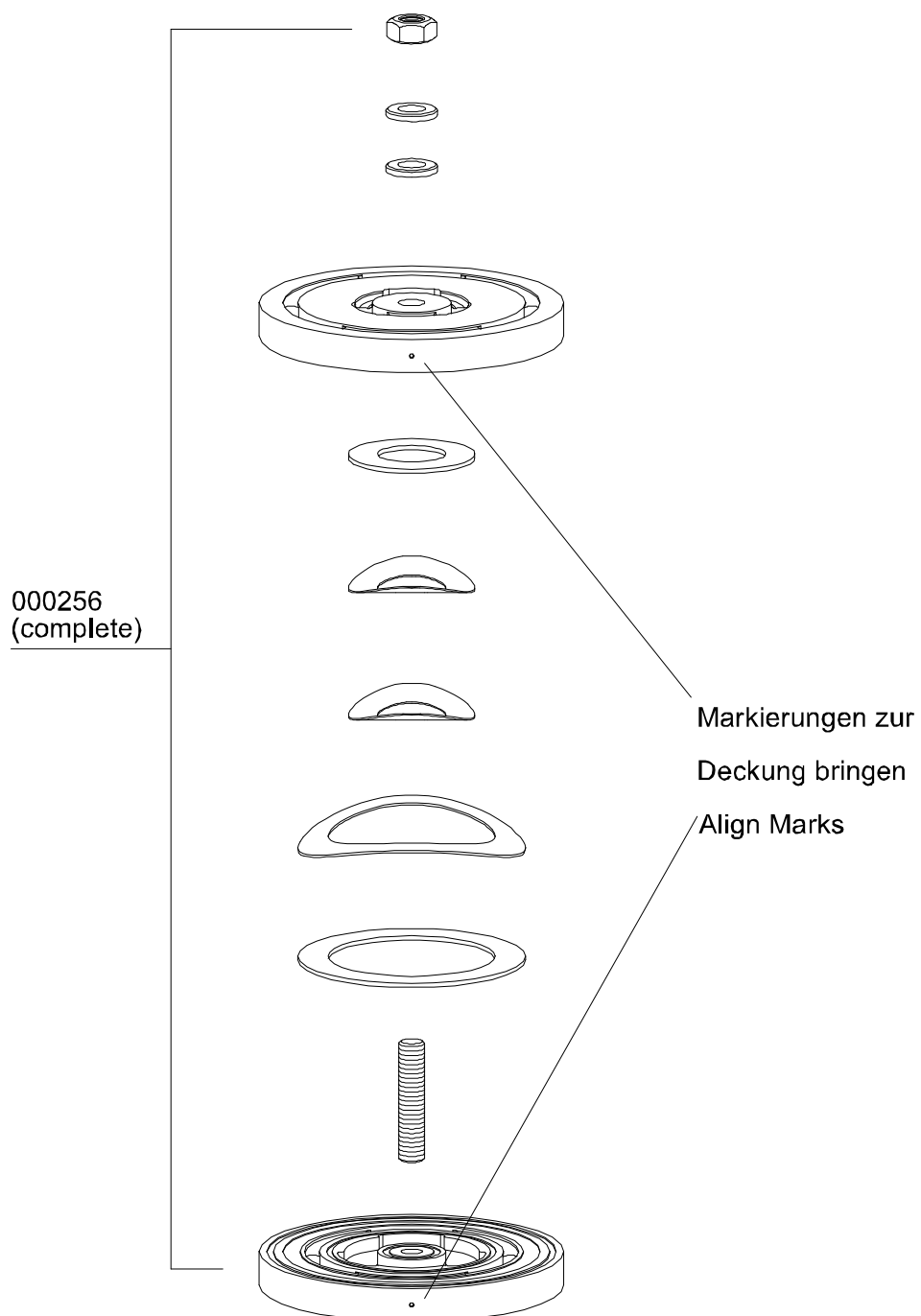

C

ERSATZTEILLISTE / SPARE PART LIST

Baugruppe: Ventil 3. Stufe / Assembly: Valve 3rd Stage

Best.-Nr. / Order No.	Benennung	Description
000527	Ventildichtung, Saug- & Druckventil	Lower Valve Gasket
000540	Dichtring / Dichtung	Upper Alloy Seal Ring
000524	Saug-Druckventil, inkl. Al-Dichtung	In- & Outlet Valve, c/w gasket

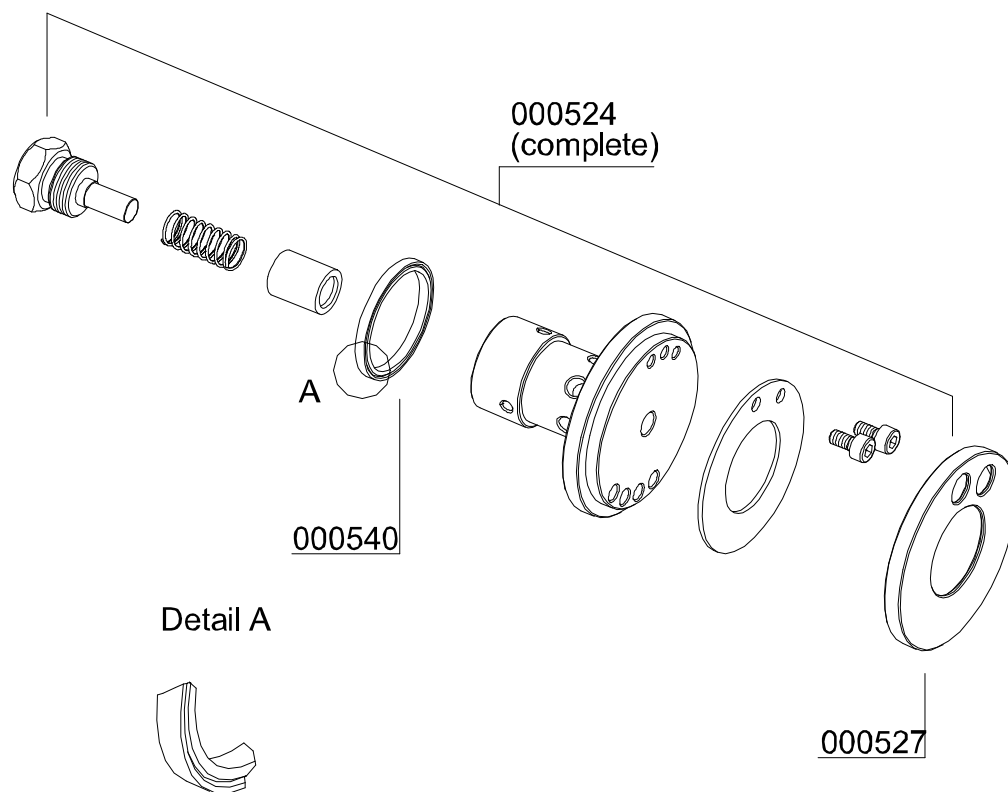



ERSATZTEILLISTE / SPARE PART LIST

Kühler 1. Stufe / Cooler 1st Stage

Best.-Nr. / Order No.	Benennung	Description
000521	Schiene 340mm	Metal Bar 340 mm
000568	Halterung	Bracket
000624	PVC Schlauch, transparent	PVC Hose for Bracket
000861	Schneidring PSR 18 LX	Olive Seal 18mm
000862	Mutter M18L	Nut 18L
001039	Zylinderschraube	Allen Screw
001058	Zylinderschraube M8x70mm DIN912 8.8 ZN	Allen Bolt
001159	Stoppmutter	Lock Nut M8
001181	U-Scheibe A8 DIN125 ZN	Washer A8
001205	4-kant Mutter	Square Nut M8
002106	Distanzbolzen M8xSW14x53mm	Spacers
002994	Wärmetauscher 1.Stufe LW 450 E inkl.	Heat Exchanger 1st Stage c/w Nut & Olive

C

DETAILANSICHT / DETAILED VIEW

Kühler 1. Stufe / Cooler 1st Stage

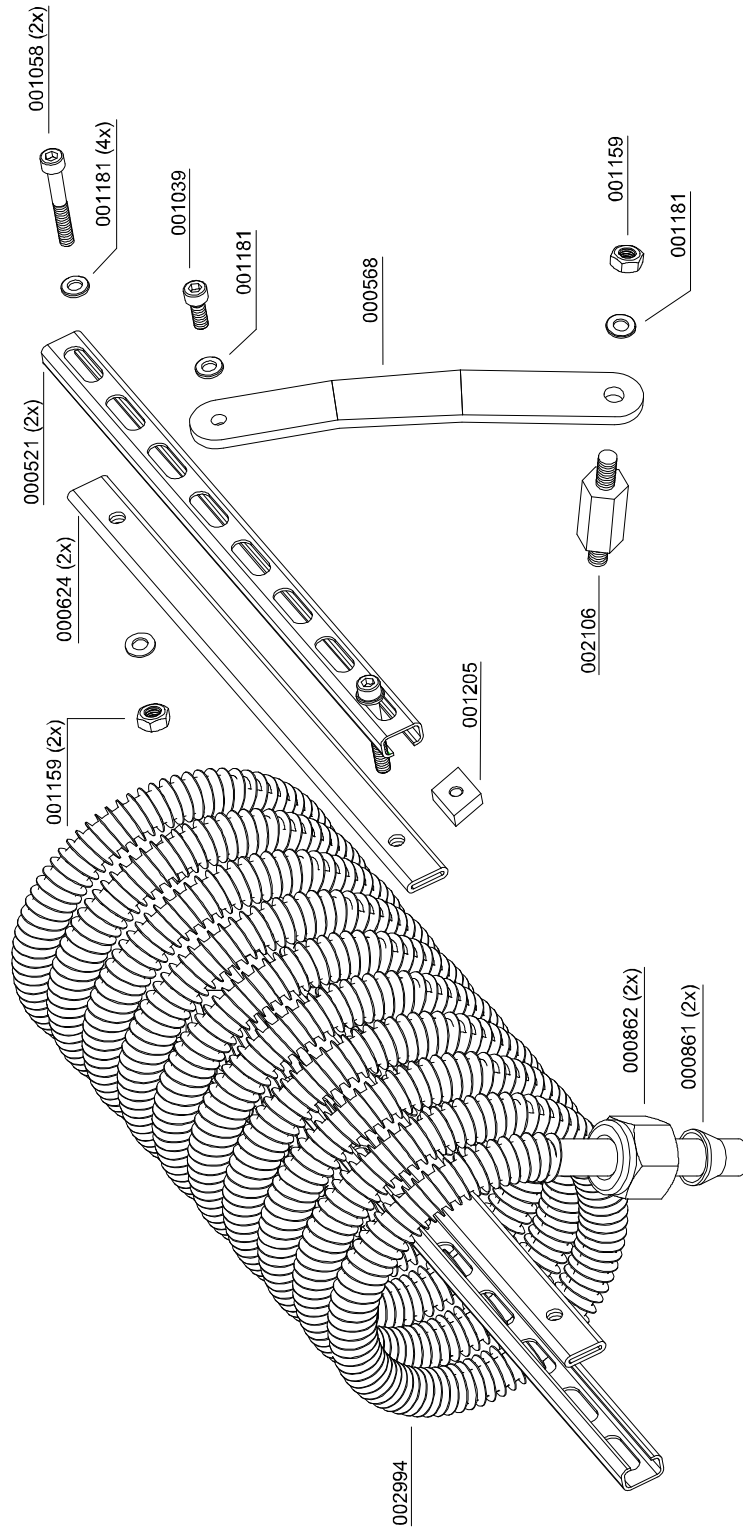

C



ERSATZTEILLISTE / SPARE PART LIST

Kühler 2. Stufe / Cooler 2nd Stage

Best.-Nr. / Order No.	Benennung	Description
000521	Schiene 340mm	Metal Bar 340 mm
000568	Halterung	Bracket
000624	PVC Schlauch, transparent	PVC Hose for Bracket
000861	Schneidring PSR 18 LX	Oliver Seal 18mm
000862	Mutter M18L	Nut 18L
001039	Zylinderschraube	Allen Screw
001058	Zylinderschraube M8x70mm DIN912 8.8 ZN	Allen Bolt
001159	Stopfmutter	Lock Nut M8
001181	U-Scheibe A8 DIN125 ZN	Washer A8
001205	4-kant Mutter	Square Nut M8
002995	Wärmetauscher 2.Stufe LW 450 D/E/ES	Heat Exchanger 2nd Stage LW 450 D/E/ES

C

DETAILANSICHT / DETAILED VIEW

Kühler 2. Stufe / Cooler 2nd Stage

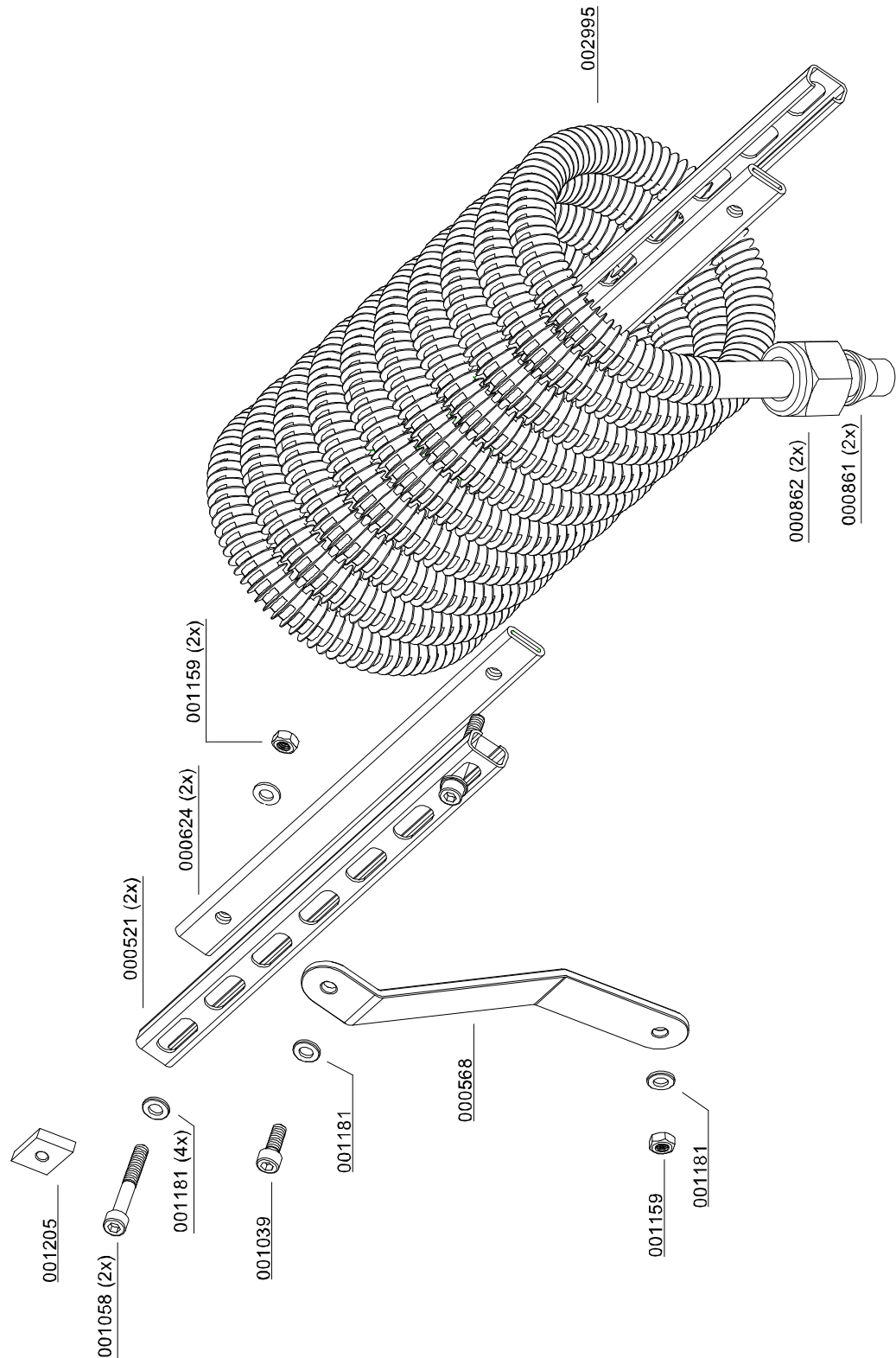

C



ERSATZTEILLISTE / SPARE PART LIST

Kühler 3. Stufe / Cooler 3rd Stage

Best.-Nr. / Order No.	Benennung	Description
000629	Doppelschelle 2 x 8mm 1 Paar	Pipe Clamp 2x8mm - 1 pair
000638	Doppelschelle 2 x 8 mm 1 Paar	Pipe Clamp 2x8mm 1pair
001026	Zylinderschraube M6x40mm DIN912 8.8 ZN	Allen Bolt M6x40mm DIN912 8.8 ZN
001028	Zylinderschraube M6x25mm DIN912 8.8 ZN	Allen Bolt M6x25mm DIN912 8.8 ZN
003224	Kühlerhalteblech	Bracket, Cooler Stage 3
003225	Kühlerhalteblech	Bracket, Cooler Stage 3
003226	Kühlrohr 3te Stufe kompl.	Cooler, 3rd stage kompl.
003574	Kühlspirale komplett inkl. Haltearme	Cooling coil (complete) incl. bracket

C

DETAILANSICHT / DETAILED VIEW

Kühler 3. Stufe / Cooler 3rd Stage

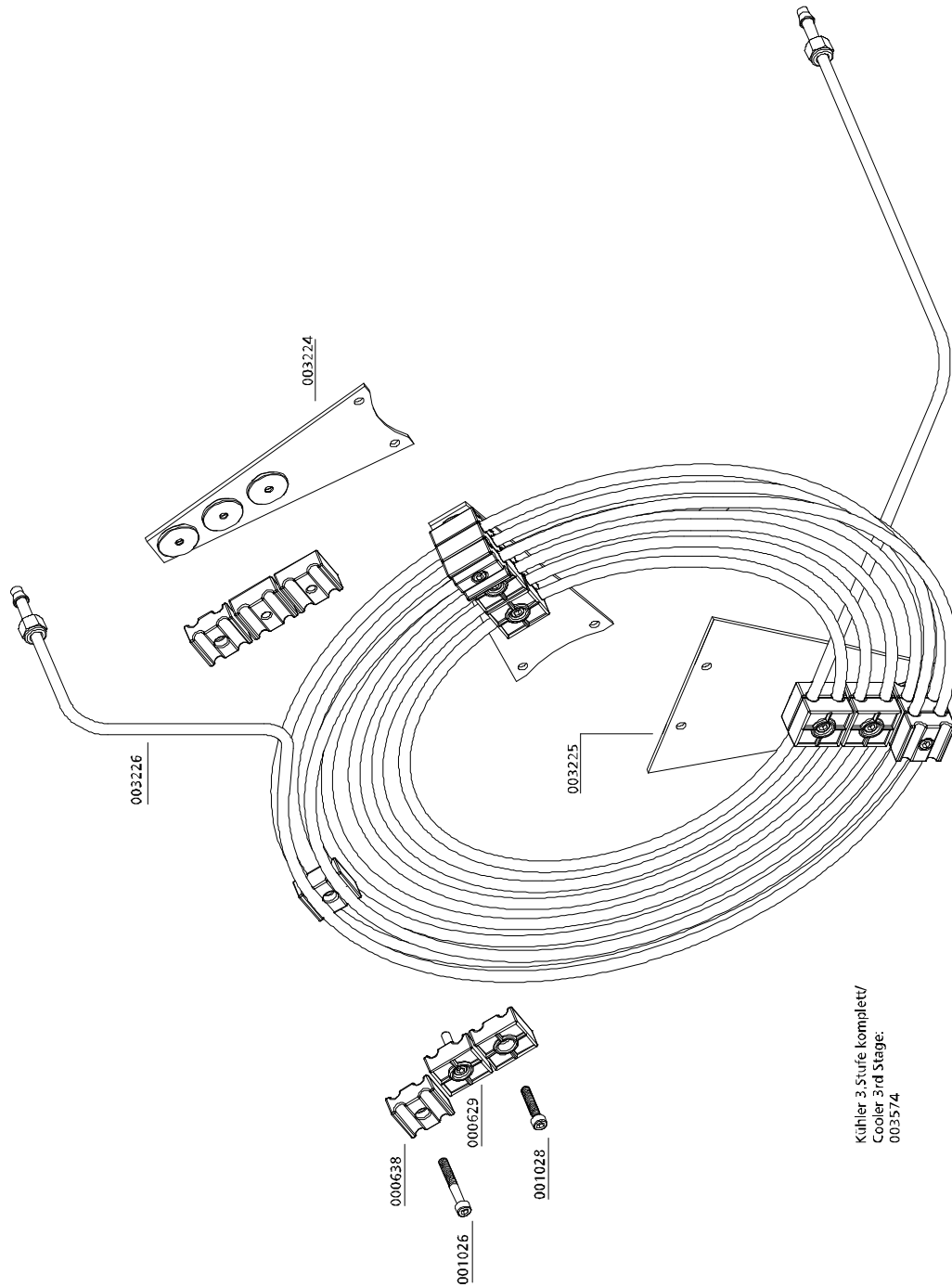

C



ERSATZTEILLISTE / SPARE PART LIST

Kolben 1. Stufe / Piston 1st Stage

Best.-Nr. / Order No.	Benennung	Description
000265	Kolbenringsatz 1.Stufe, Ø 95mm	Piston Ring Set 3pcs
000266	Kolben komplett 1.Stufe, Ø 95mm	Piston complete 1.Stage, Ø 95mm
001356	Sicherungsring, I22 DIN472	Circlip I22 DIN472
003900	Kolbenbolzen 1.Stufe, Ø 22x85mm	Piston Pin, 1.Stage, Ø 22x85mm

C

DETAILANSICHT / DETAILED VIEW

Kolben 1. Stufe / Piston 1st Stage

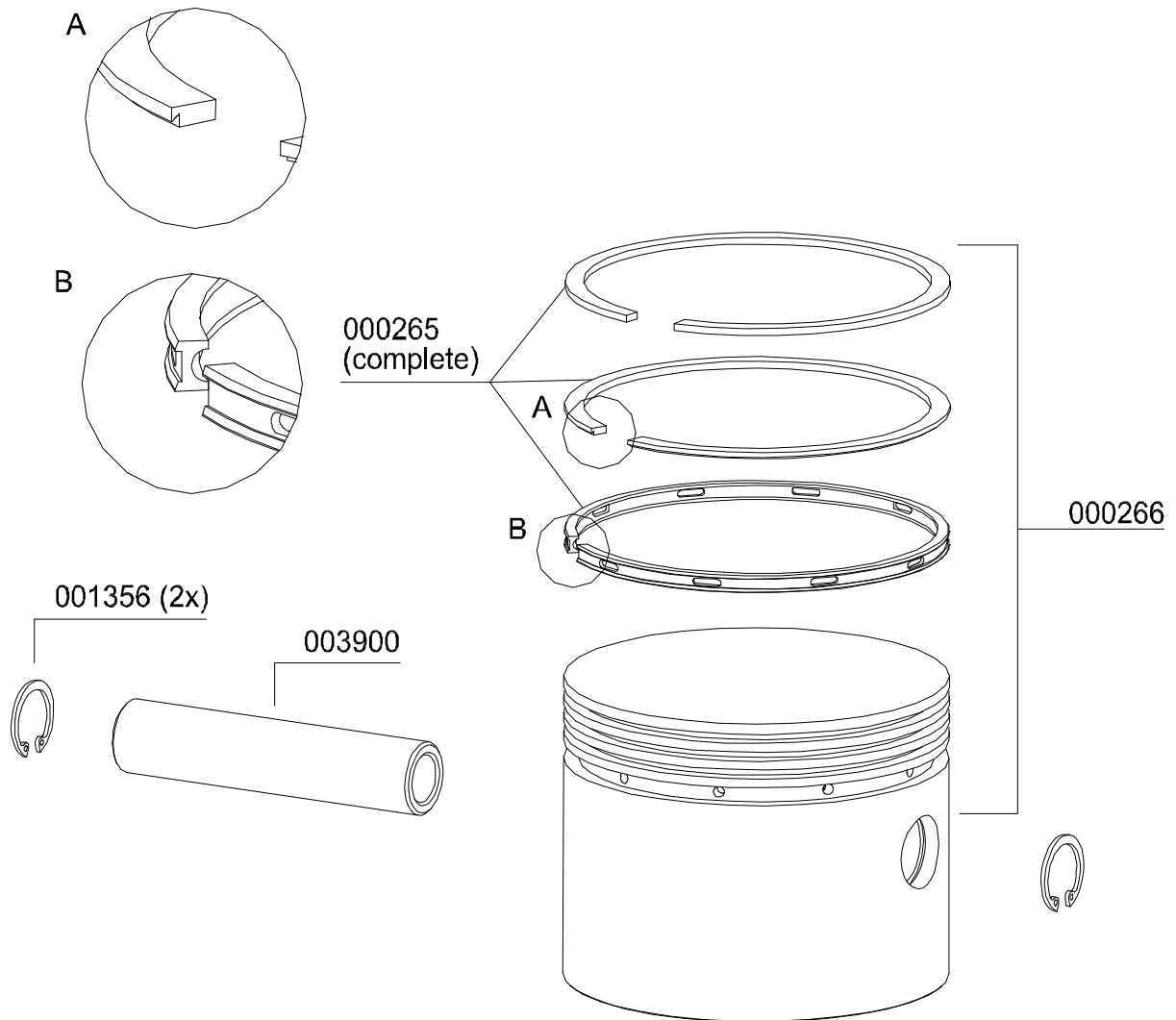



ERSATZTEILLISTE / SPARE PART LIST

Kolben 2. Stufe / Piston 2nd Stage

Best.-Nr. / Order No.	Benennung	Description
000263	Kolbenringsatz 2.Stufe, 4 Stk.,Ø42 mm	Piston Ring Set 2.Stage, 4pcs, Ø42mm
000264	Kolben kompl. mit Kolbenringen, 2.Stufe, Ø42x70mm	Piston c/w Rings, 2.Stage, Ø42x70mm
001002	Kolbenbolzen 2. + 3.Stufe, A16x33mm	Piston Pin 2.+3.Stage, A16x33mm
001353	Sicherungsring, I 16 DIN472	Circlip I 16

C

DETAILANSICHT / DETAILED VIEW

Kolben 2. Stufe / Piston 2nd Stage

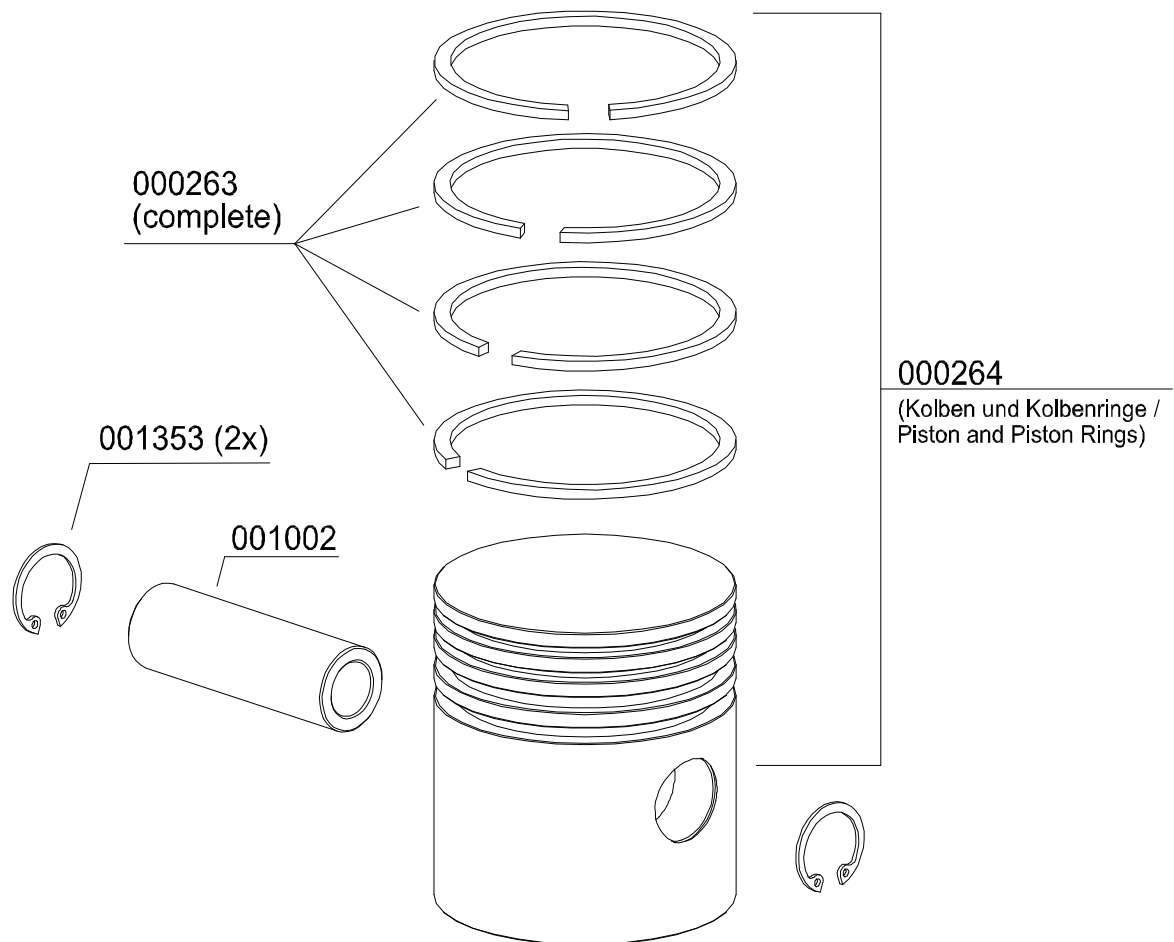

C



ERSATZTEILLISTE / SPARE PART LIST

Kolben 3. Stufe / Piston 3rd Stage

Best.-Nr. / Order No.	Benennung	Description
001002	Kolbenbolzen 2. +3.Stufe	Piston Pin 2. +3.Stage
001353	Sicherungsring, I 16 DIN472	Circlip I 16 DIN472
002126	Kolben kompl. mit Kolbenringen, Bolzen u. Sicherungsringen, 3.Stufe	Piston c/w Piston Rings, Piston Pin and Circlips
002324	Kolbenringsatz 3.Stufe,	Piston Rings 3.Stage
003285	Spezialwerkzeugsatz zur Kolbenring- u. Kolbenmontage	Special Tool Kit 3.Stage

C

DETAILANSICHT / DETAILED VIEW

Kolben 3. Stufe / Piston 3rd Stage

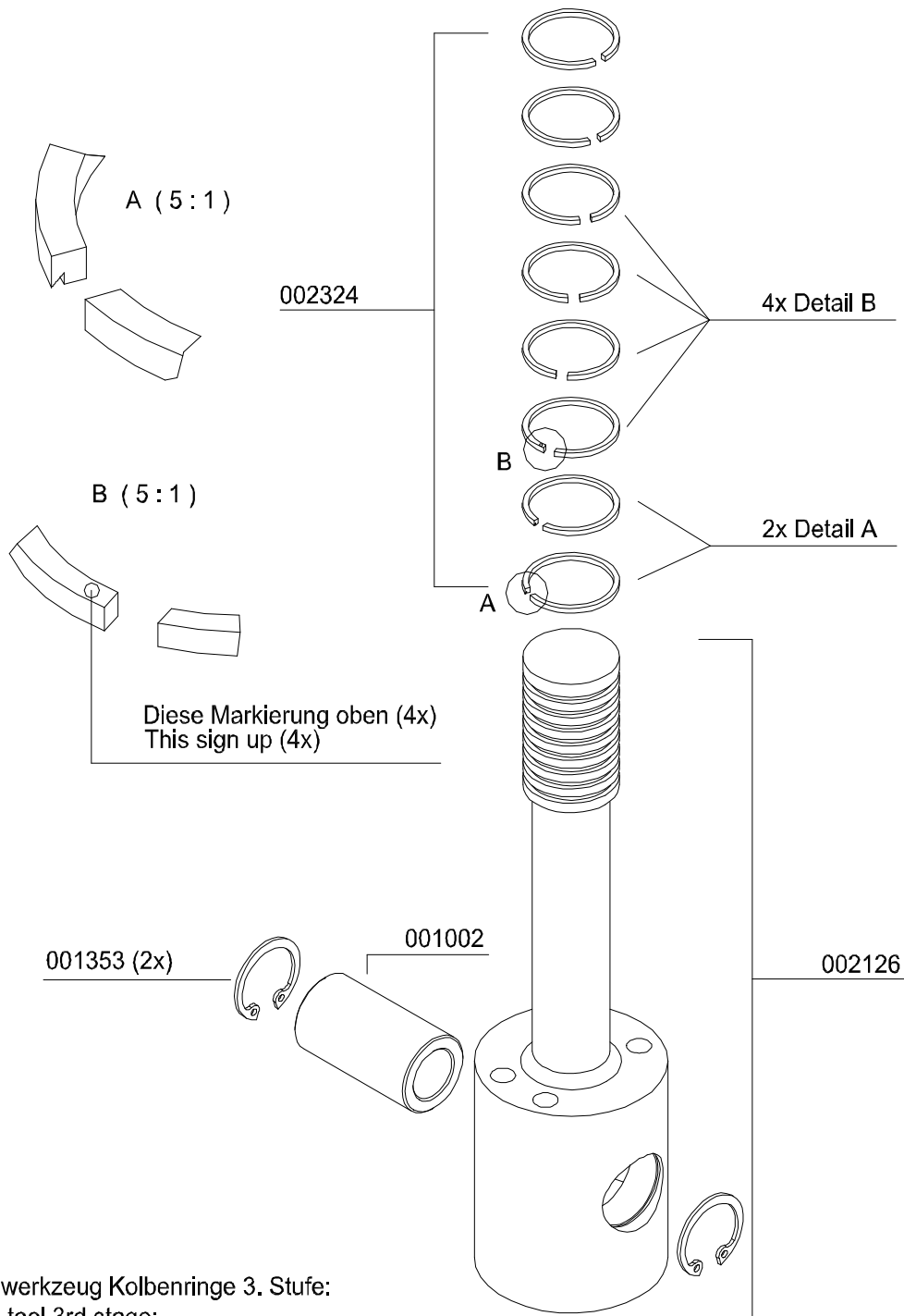

Spezialwerkzeug Kolbenringe 3. Stufe:
Special tool 3rd stage:
003285

C



ERSATZTEILLISTE / SPARE PART LIST

Kurbelwelle / Crankshaft

Best.-Nr. / Order No.	Benennung	Description
000242	Sicherung und Scheibe 450	Thrust Washer & Circlip
000247	Anlaufscheibe Kurbelwelle, mit Innenfase	Thrust Washer, chamfered version
000248	Ölschleuderring	Oil Splash Ring
000249	Gewindebügel M6x34x25	Threated Elbow M6x34x25
000250	CU-Ring $\text{Æ}6,2 \times 10 \times 1,5 \text{mm}$	Copper Washer
000267	Pleuel LW 450 1.Stufe	Conrod 1 st Stage LW 450
000268	Pleuel LW 450 2.&3.Stufe	Conrod c/w Needle Bearing
000269	Kurbelwelle komplett LW 450	Crankshaft c/w Counter Weight
001157	Hutmutter M6 DIN 1587 ZN	Domed Nut M6 DIN 1587 ZN
001189	Schnorrzscheibe S10 N0110 ZN	Clamp Washer S10 N0110 ZN
001207	Passfeder, A8x7x35mm DIN6885	Woodruff Key
003836	Nadellager	Needle Bearing
004809	Konischer Schraubenkopf, M6x8 mm,	Drive bolt
007267	Zylinderschraube M10x45mm DIN912 10.9	Allen Bolt M10x45mm DIN912 10.9

C

DETAILANSICHT / DETAILED VIEW

Kurbelwelle / Crankshaft

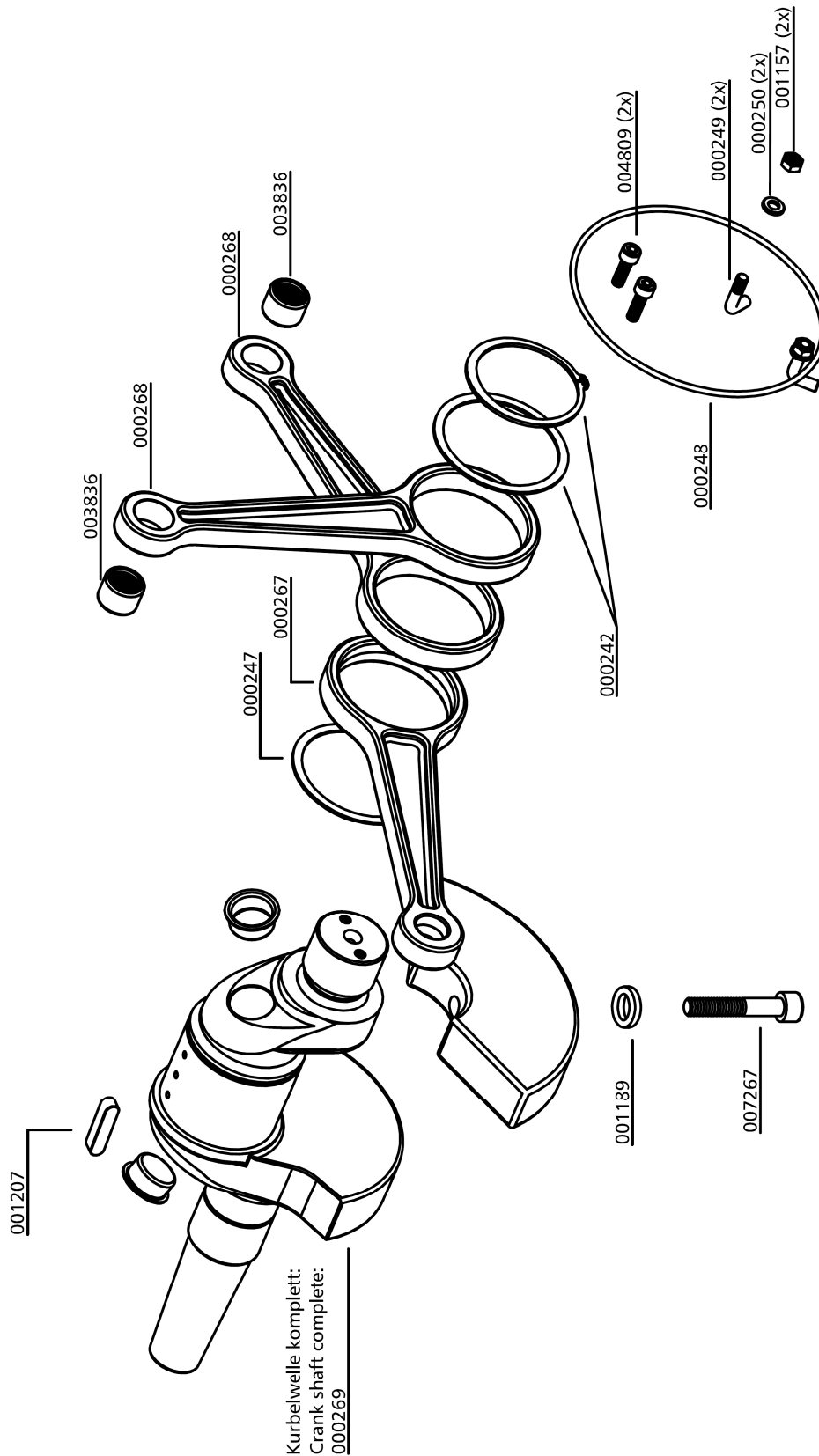



ERSATZTEILLISTE / SPARE PART LIST

Baugruppe: Ölablassschlauch / Assembly: Oil Drainage Tube

Best.-Nr. / Order No.	Benennung	Description
000817	Verschraubung	Connection
001005	Zylinderschraube, M5x16mm DIN912 8.8 ZN	Allen Screw, M5x16mm DIN912 8.8 ZN
001176	U-Scheibe, A5 DIN125 ZN	Washer, A5 DIN125 ZN
001548	Ölablassventil (Kugelhahn)	Oil Drain Valve - ball valve
002153	Ölablassschlauch inkl. Kugelhahn	Oil drain hose c/w ball valve
006417	Ölablassschlauch	Oil Drain Hose
006964	Klemmhalter Ölablassschlauch	Clamp Oil Drain Hose

C

DETAILANSICHT / DETAILED VIEW

Baugruppe: Ölablassschlauch / Assembly: Oil Drainage Tube

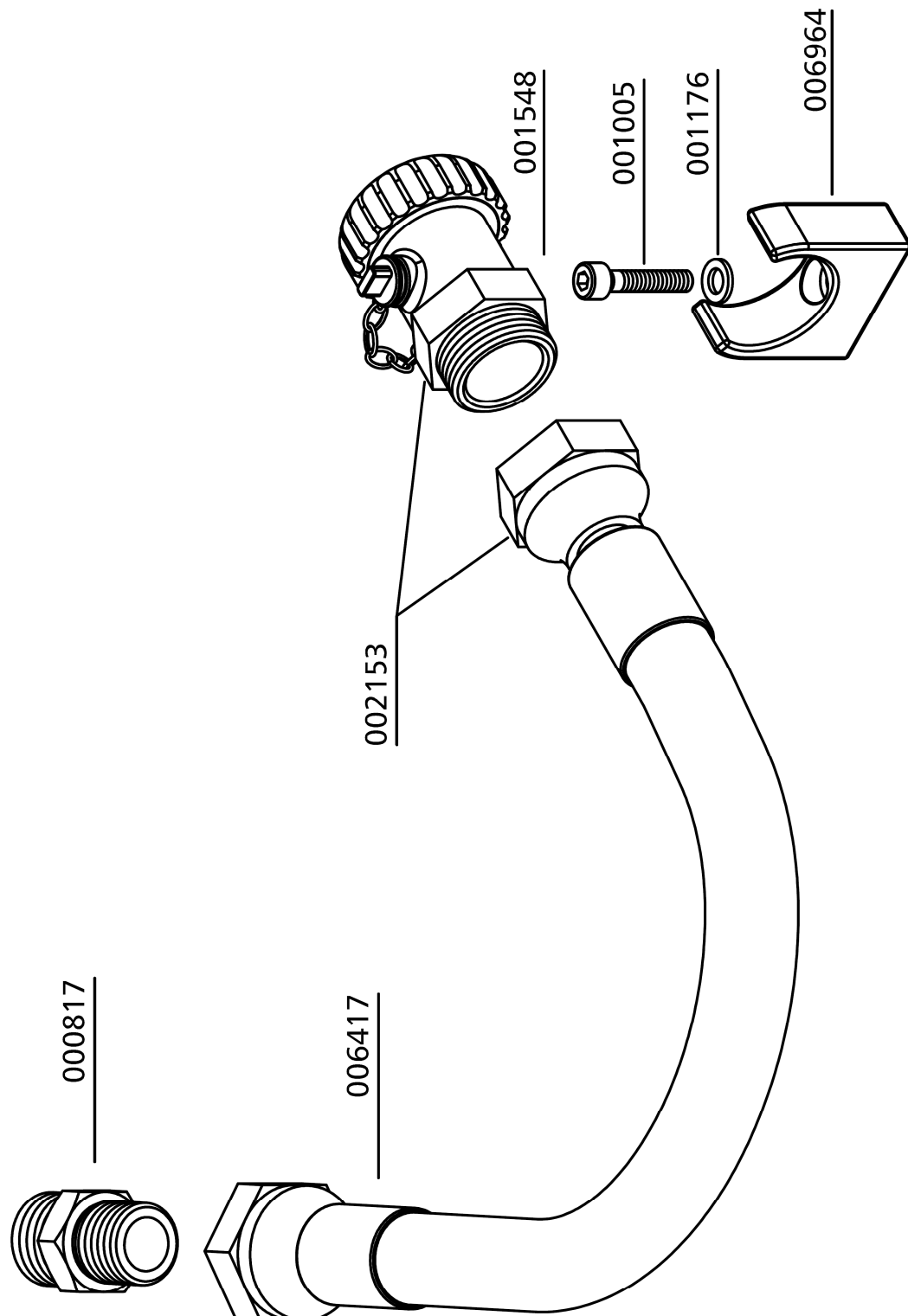

C

ERSATZTEILLISTE / SPARE PART LIST

Füllschlauch / Filling Hose

Best.-Nr. / Order No.	Benennung	Description
005295	Hochdruckschlauch 10L, 1500 mm, drehbar	HP-Hose 10L 1500 mm, rotatable

005295



BG : Füllventil
Ass: Filling Valve

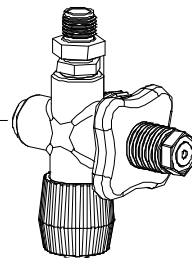

ERSATZTEILLISTE / SPARE PART LIST

Baugruppe: Kreuzventil / Assembly: Cross Design Valve

Best.-Nr. / Order No.	Benennung	Description
000213	Handrad, schwarz DIN 200bar	Hand Wheel DIN 200 bar, black
000215	Handrad rot DIN 300bar	Hand Wheel DIN 300 bar, red
000386	Gleitscheibe, Kreuzventil	Slide Washer
000387	Feder (Kreuzventil)	Coil Spring, cross d. valve
000665	Manometer Messing	Pressure Gauge, brass
000666	Manometerschutzkappe Ø63mm	Protector Pressure Gauge Ø63mm
000696	Füllanschluss o. Handrad 200bar	Filling Connector w/o handwheel 200bar
000698	Füllanschluss o. Handrad 300bar	Filling Connector w/o handwheel 300bar
000709	Füllventil Kreuzbauweise, kompl.	Filling Valve cross design
001237	O-Ring DIN Flaschenanschluss	O-Ring DIN filling connector
001391	O-Ring	O-Ring
001392	Füllhandrad Kreuzventil	Hand Wheel Filling Valve cross
001393	Entlüftungsspindel	Vent Spindle
001394	Entlüftungshandrad	Vent Hand Wheel
001395	Gleitscheibe, schwarz, Kreuzventil	Slide Washer, plastic black
001397	Kupferdichtung	Copper Seal Ring
001398	Madenschraube	Worm Screw
001399	Oberspindel	Adapter Shaft
001400	Dichtspindel, Kreuzventil	Seal Spindle Filling Valve
001401	Schlitzmutter	Slotted Nut
001402	Gehäuseverschraubung komplett mit O-	Filling Spindle Body c/w O-Rings
002812	Verschraubung, Edelstahl	Connection, S/S
003687	Füllventil Kreuzbauweise komplett 200bar	Filling Valve cross complete unit 200bar
003688	Füllventil Kreuzbauweise komplett 300bar	Filling Valve cross complete unit 300bar

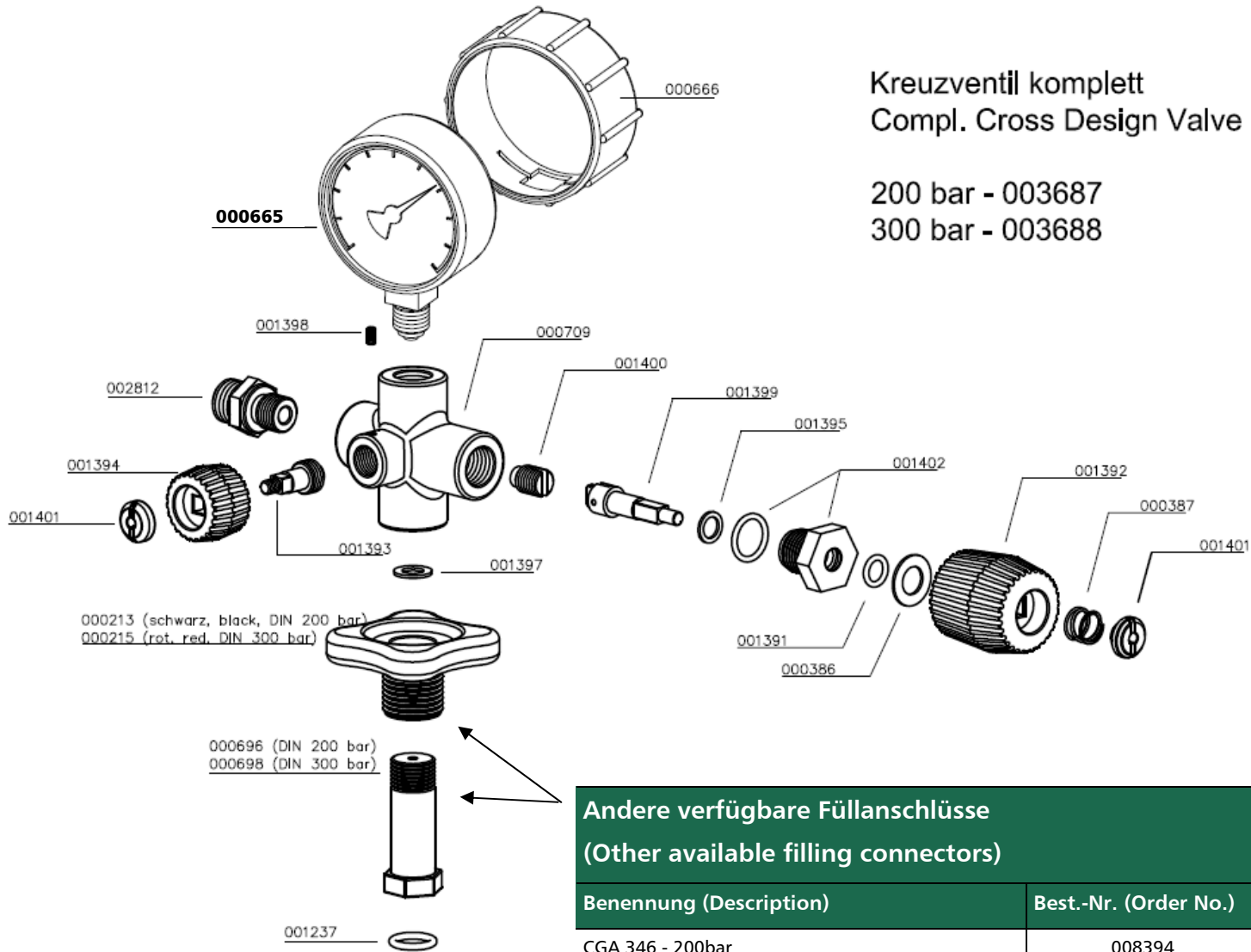

Kreuzventil komplett
Compl. Cross Design Valve

200 bar - 003687
300 bar - 003688

**Andere verfügbare Füllanschlüsse
(Other available filling connectors)**

Benennung (Description)	Best.-Nr. (Order No.)
CGA 346 - 200bar	008394
CGA 347 - 300bar	006842
INT / Yoke - 200/232 bar	002307

DETAILANSICHT / DETAILED VIEW

Baugruppe: Kreuzventil / Assembly: Cross Design Valve





OPTIONS



Table of Contents

Auto Shut Down.....	1
Automatic Condensation Drain.....	6
Auto Start Function.....	17
Oil Pressure Gauge	23
Oil Pressure Monitoring	26
Oil Temperature Monitoring	32
Cylinder Head Temperature Monitoring	35
Interstage Pressure Gauges.....	38
200+300bar Parallel Filling Pressure Operation.....	41
Air Cooler Connection Kit.....	48
Condensate Tank 60L	51



AUTO SHUT DOWN

D

AUTO SHUT DOWN

Final pressure switch

The pressure switch shuts off the compressor automatically when the selected final pressure is reached. The final pressure switch is already adjusted to the corresponding cut-out pressure.

The pressure can be adjusted with the upper adjusting screw as follows:

Increasing cut-out pressure:

Turn the adjusting screw clockwise

Reducing cut-out pressure:

Turn the adjusting screw anti-clockwise

Adjust the pressure switch in steps of a quarter turn.

Restart the compressor after every adjustment step to verify the actual cut-out pressure.

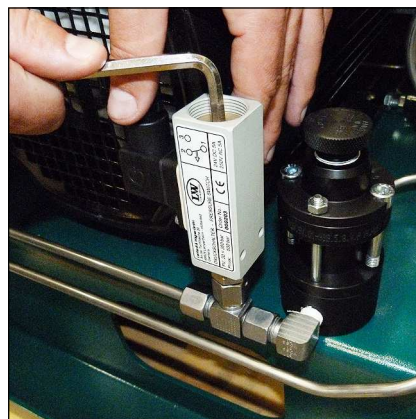

Final pressure switch

D



Note

Do not adjust the final pressure switch to the safety valve pressure. The final pressure switch has to be adjusted to min. 10 bar below the safety valve pressure. Otherwise, the safety valve can open during operation. This considerably reduces the life of the safety valve.

Example settings:

Safety valve	Max. Operating Pressure
225 bar	215 bar
250 bar	240 bar
330 bar	320 bar

AUTO SHUT DOWN

Safety valve test



Note

Do not fill any tank during test phase!

Safety valve test as follows:

- Disconnect compressor from the electrical power supply and protect against unexpected restart.
- Remove the cover of the switch box.
- Switch on the "Test Safety Valve" switch (pressure switch will be deactivated!).
- Mount the cover of the switch box.
- Connect the compressor to the electrical power supply.
- Close filling valves.
- Start the compressor.
- Watch the final pressure gauge. The safety valve should open when reaching working pressure of the compressor. If not, switch off the unit and take out of service until the safety valve has been replaced.
- Switch off the compressor.
- Disconnect the compressor from the electrical power supply and protect against unexpected restart.
- Remove the cover of the switch box.
- Switch off the "Test Safety Valve" switch (pressure switch will be activated!).
- Mount the cover of the switch box.
- Connect the compressor to the electrical power supply.

The safety valve test is now completed.

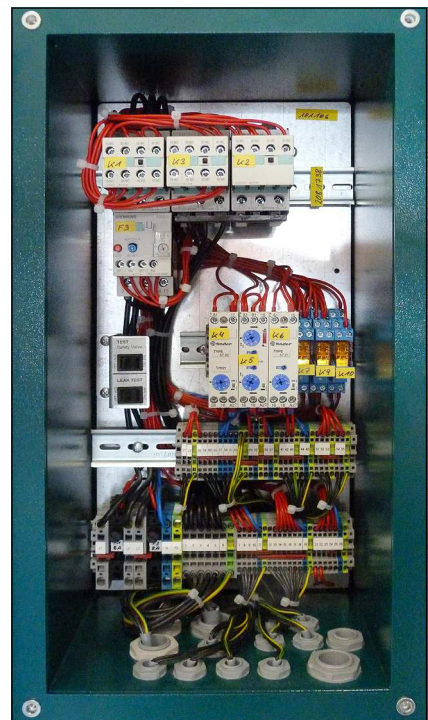

Switch box

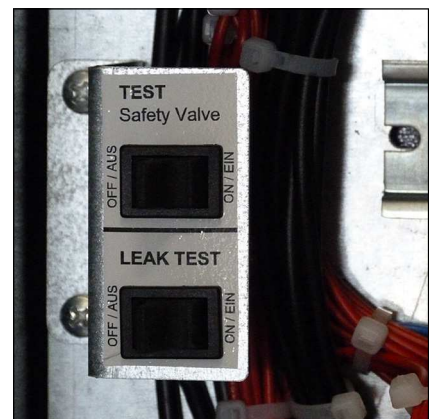

Safety valve test switch (up)



AUTO SHUT DOWN

Druckschalter / Pressure Switch

Best.-Nr. / Order No.	Benennung	Description
000203	Druckschalter 50-350 bar	Pressure Switch 50-350 bar
000749	Verschraubung, mit fester Mutter	Connection with fixed nut
000757	T-Verschraubung mit fester Mutter seitl. EL 08 L	T-Connection with fixed nut EL 08 L
000765	Schneidring PSR 08 LX	Olive Seal PSR 08 LX
000766	Mutter 08L CFX	Nut 08L CFX

D

AUTO SHUT DOWN

Druckschalter / Pressure Switch

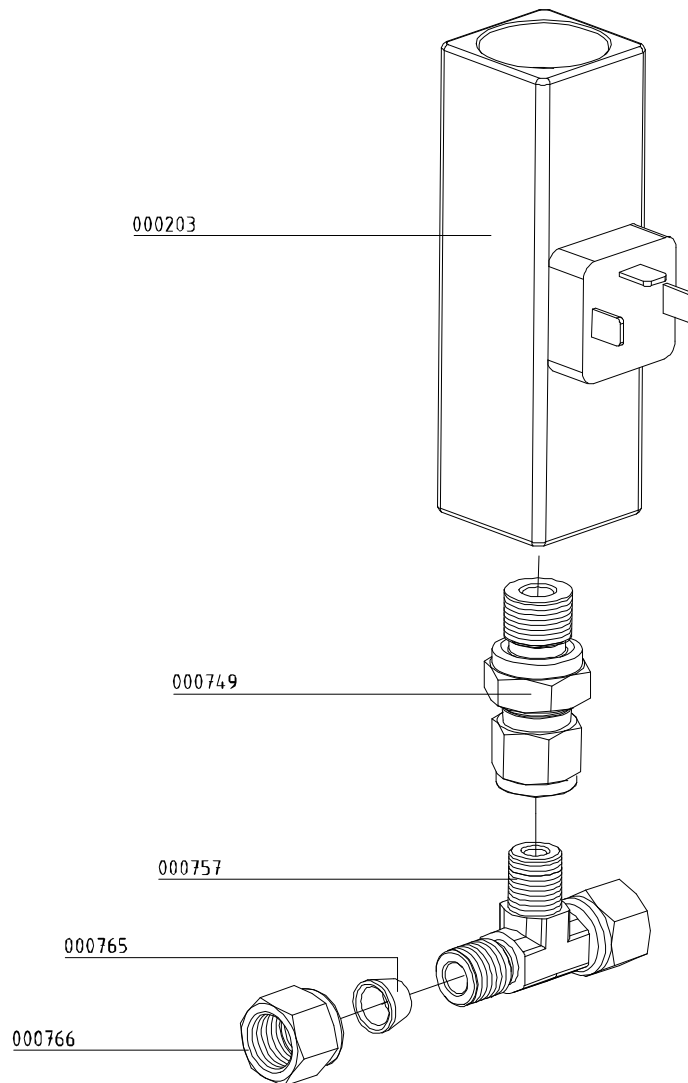

D



AUTOMATIC CONDENSATION DRAIN

D

AUTOMATIC CONDENSATION DRAIN

Automatic condensation dump system



Note

The collected condensate can contain oil and has to be disposed according to regulations.

The LW 450 E Compact comes as standard with an automatic condensation dump system. Solenoids drain all condensate separators every 15 minutes.

To test the system, press the blue condensate test drain button on the operating panel.

Oil / water separators

Condensate is separated after every stage of compression. All three oil / water separators are equipped with electronic timer controlled solenoids. The timer is located in the switch box and activates the dump valves about every 15 minutes.

To release the complete condensate through the black plastic hoses, we recommend using an 20 l container at least.

The drain noise can be kept to a minimum by using a silencer.

Maintenance intervals

We recommend to clean oil and water separators every 500 operating hours or at least once a year, to check for corrosion damage and to replace o-rings if necessary.

All oil / water separators have an integrated sinter filter which has to be replaced every 1,000 operating hours.

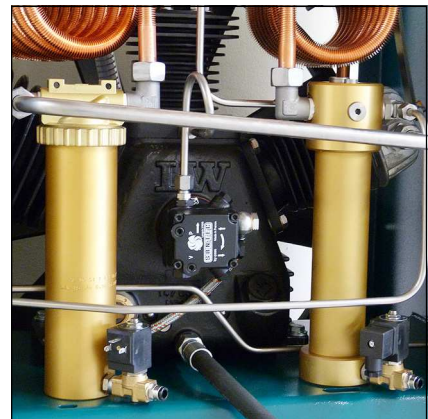

Oil / water separators 1st and 2nd stage

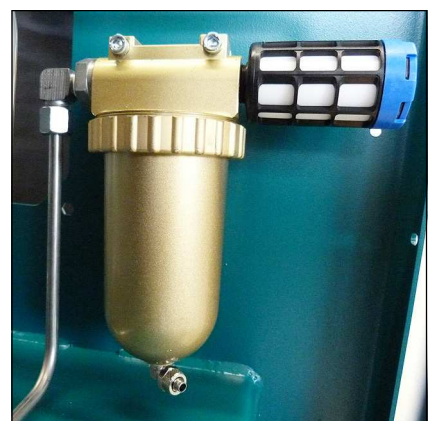

Oil / water separators final stage

AUTOMATIC CONDENSATION DRAIN

Leak test



Note

Do not fill any tank during test phase!

Leak test as follows:

- Disconnect the compressor from the electrical power supply and protect against unexpected restart.
- Remove the cover of the switch box.
- Switch on the leak test switch (solenoid valves will be deactivated!).
- Mount the cover of the switch box.
- Connect the compressor to the electrical power supply.
- Close filling valves.
- Start the compressor.
- Switch off the compressor at a pressure of approx. 150 bar.
- Verify the compressor for release noises. (A slight hiss of the air inlet filter nozzle can be ignored). If release noises occur, localise blow off position(s).
- Switch off the compressor.
- Disconnect the compressor from the electrical power supply and protect against unexpected restart.
- Remove the cover of the switch box.
- Switch off the leak test switch (solenoids will be activated!).
- Mount the cover of the switch box.
- Connect the compressor to the electrical power supply.

The leak test is now completed.

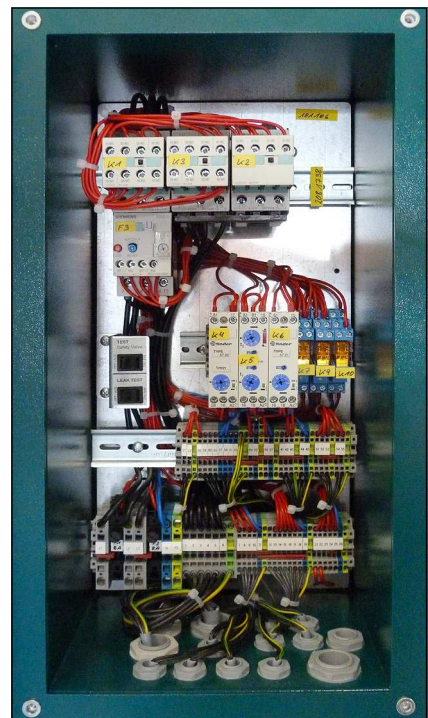

Switch box



Leak test switch (lower)

AUTOMATIC CONDENSATION DRAIN

Oil / water separators final stage - maintenance



Note

Clean all parts thoroughly before assembly.

Change/clean oil / water separators final stage as follows:

- Loosen pipe connections and mounting screws.
- Remove oil / water separators.
- Open ring nut and remove separator top (Fig. 1).
- Loosen nut at the separator top.
- Change sinter filter (Fig. 2).
- Reassemble all parts and tighten nut.
- Change o-ring, previously grease new o-ring (Fig. 3).
- Place separator top and tighten ring nut manually.
- Replace silencer.
- Mount oil / water separators.
- Tighten pipe connections and mounting screws.

The oil / water separator maintenance is now completed.



Oil / water separators final stage



Fig. 1 - Loosen ring nut

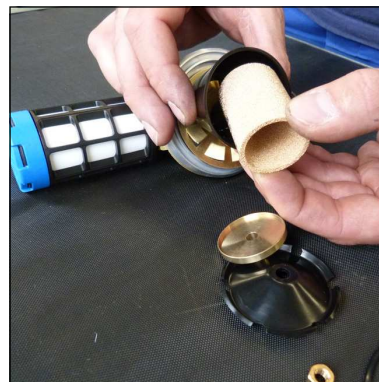

Fig. 2 - Change sinter filter

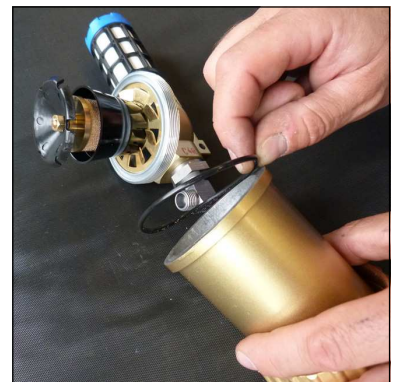

Fig. 3 - Change o-ring

AUTOMATIC CONDENSATION DRAIN

Pneumatic condensate valve - maintenance



Note

Clean all parts thoroughly before assembly.

Pneumatic condensate valve change as follows:

- Loosen pipe connections and mounting screws.
- Remove pneumatic condensate valve.
- Loosen connection (Fig. 2).
- Change sinter filter (Fig. 3).
- Tighten horizontal screw.
- Mount pneumatic condensate valve.
- Tighten pipe connections and mounting screws.

Pneumatic condensate valve maintenance is now completed.

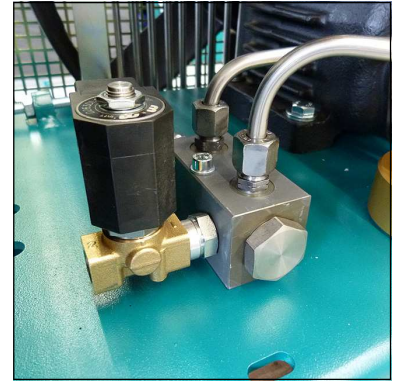

Pneumatic Condensate Valve



Fig. 2 - Loosen connection

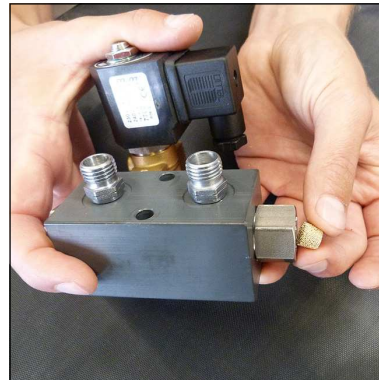

Fig. 3 - Change sinter filter



AUTOMATIC CONDENSATION DRAIN

Öl- / Wasserabscheider Endstufe / Oil- / Water Separator Final Stage

Best.-Nr. / Order No.	Benennung	Description
000175	Deckel, Wasserabscheider	Cap
000178	Schalldämpfer G1/2"	Silencer G1/2"
000182	Endstufe Wasserabscheider (PN 15	Water Separator c/W bracket
000183	Wasserabweiser	Filter Protecor
000184	Sinterfilter Wasserabscheider	Siltered Filter, Oil Filter
000185	Halteteller	Plate
000186	Drallscheibe	Twist Disk
000395	Blechhalter Kondensatabscheider	Bracket water separator
000497	Mutter M6	Nut M6
000498	Unterlegscheibe	Washer A6
000761	Verschraubung WE 08 PLR CFX	Connection
000765	Schneidring PSR 08 LX	<i>Olive Seal 8mm</i>
000766	Mutter 8L	Nut 8L
000921	Reduzierung 1/2"-1/4"	Reducer 1/2"-1/4"
000948	Flachkopfschraube M6x16mm DIN6912 8.8 ZN	Pan Head Bolt M6x16mm DIN6912 8.8 ZN
001027	Zylinderschraube M6x30	Allen Bolt M6x30
001156	Stopfmutter M6 DIN985 ZN	Lock Nut M6
001294	O-Ring 68x3 NBR90	O-Ring 68x3
001431	Befestigungsring Wasserabscheider	Lock Ring Water Separator
002409	Winkelschnellkupplung G1/8"-8mm	Quick release coupling elbow
002466	Kondensatbehälter für Abscheider	Condensate bowl
002563	Wasserabscheider Oberteil PN 15 bar	Water Separator, upper comp. PN15 bar

D

AUTOMATIC CONDENSATION DRAIN

Öl- / Wasserabscheider Endstufe / Oil- / Water Separator Final Stage

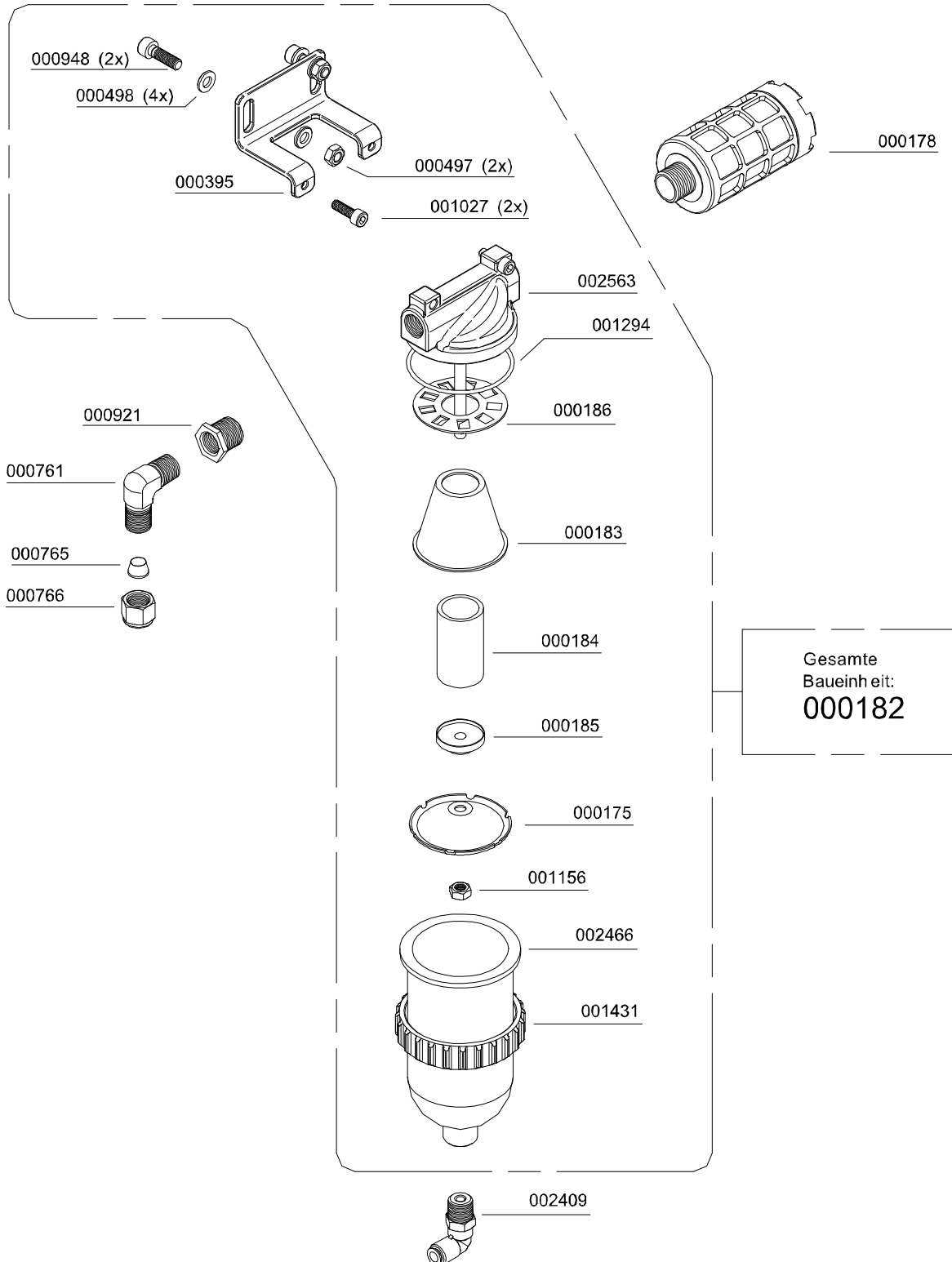

D



AUTOMATIC CONDENSATION DRAIN

Pneum. Kondensat-Ablassventil / Pneumatic Condensate Valve

Best.-Nr. / Order No.	Benennung	Description
000188	Sinterfilter	Sintered Filter
000191	Steuerkolben, pneum. Kondensatventil	Piston
000194	Reparatursatz pneum. Kondensatventil	Repair Kit Condensate Valve
000196	Düsenschraube, pneum. Kondensatventil	Inlet Jet Screw
000197	Stopfen, pneum. Kondensatventil	Plug
000198	Gehäuse, pneum. Kondensatventil	Body PCV
000199	Pneum. Kondensatventil (Kondensatablassventil)	Pneumatic Condensate Valve
000498	U-Scheibe DIN 125 A6	Washer DIN 125 A6
000737	Verschraubung GE08LR1/8CFX	Connection GE08LR1/8CFX
000738	Verschraubung GE08LR1/8CFX	Connection GE08LR1/8CFX
000765	Schneidring PSR 08 LX	Olive Seal PSR 08 LX
000766	Mutter M08LCFX	Union Nut M08LCFX
001011	Zylinderschraube M6x60mm DIN912 8.8 ZN	Allen Bolt M6x60mm DIN912 8.8 ZN

D

AUTOMATIC CONDENSATION DRAIN

Pneum. Kondensat-Ablassventil / Pneumatic Condensate Valve

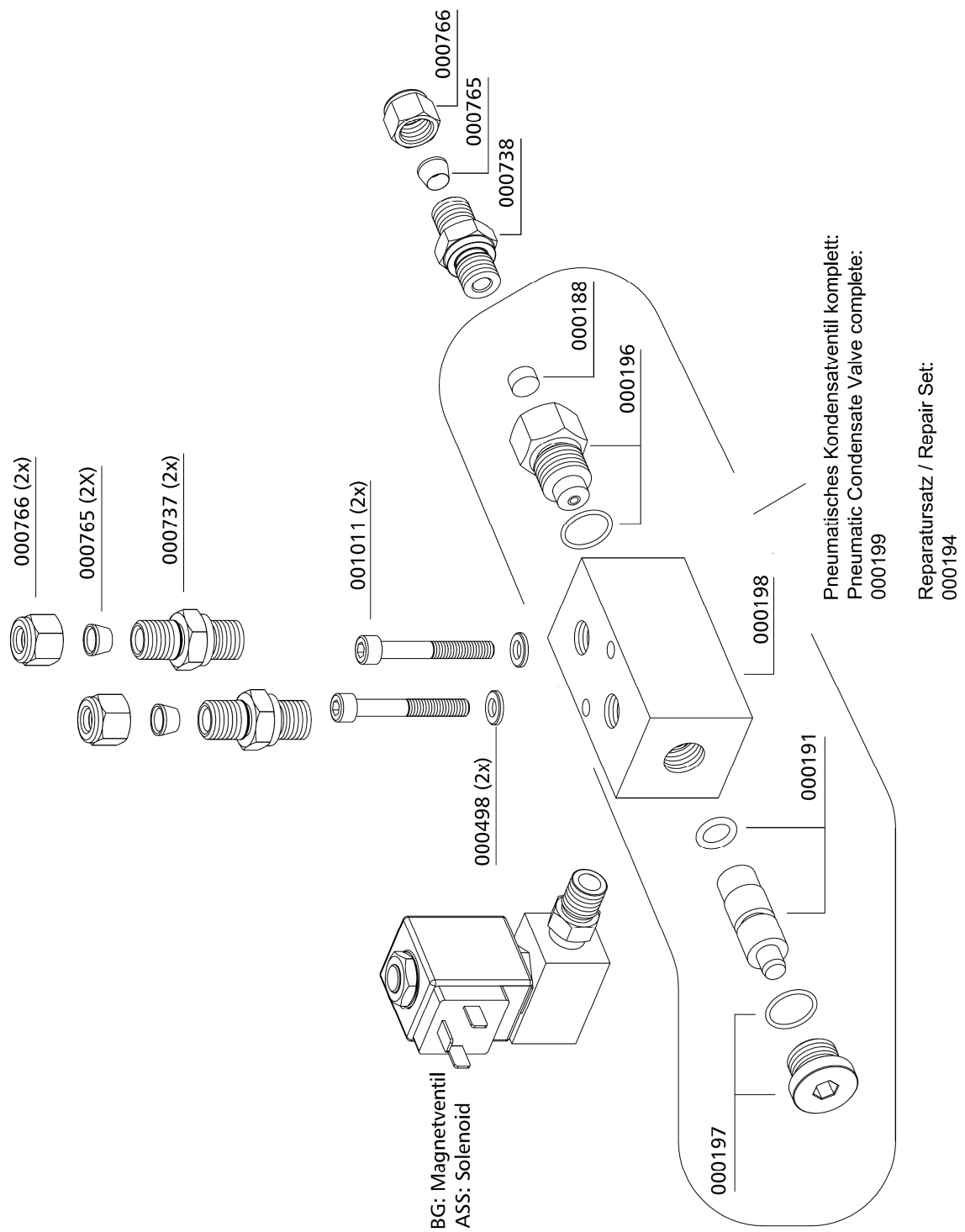

D

AUTOMATIC CONDENSATION DRAIN

Baugruppe: Magnetventil / Assembly: Solenoid

Best.-Nr. / Order No.	Benennung	Description
000892	Doppelnippel 4F3MK4S G1/8"-1/4"	Double Nipple 4F3MK4S G1/8"-1/4"
001546	Aludichtring für Magnetventile G1/4", 18 x 13,2 x 2,5mm	Alloy Seal Ring for solenoid G1/4", 18 x 13,2 x 2,5mm
005857	Gerade Einschraubverschraubung, G1/4" - 8 mm	Straight Hose Connection, G1/4" - 8 mm
006113	Magnetventil 0-55bar, komplett mit Spule	Solenoid 0-55bar, c/w coil

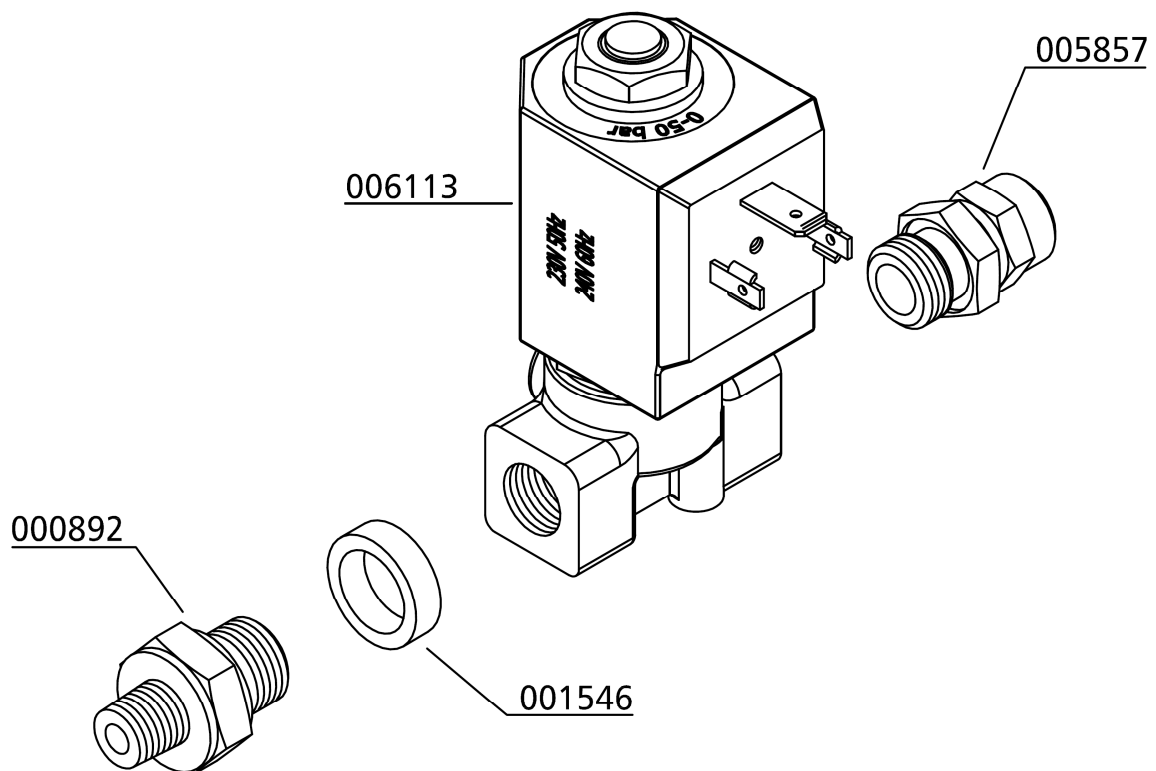

AUTOMATIC CONDENSATION DRAIN

Switch box with condensate drain test switch

Best.-Nr. / Order No.	Benennung	Description
002089	Betriebsstundenzähler	Hour counter
002502	Kondensat Test Schalter	Drain test switch
002942	START/STOP Schalter mit LED	Start/Stop switch c/w LED
003121	NOT-AUS Schalter	Emergency switch
004704	Warnlampe	Warning Lamp
005670	Einlegeschild Kondensat Test	Label Drain Test
006859	Schildträger	Label holder
006925	Einlegeschild Motorschutz	Label Motor protect

D





AUTO START FUNCTION

D

AUTO START FUNCTION

Auto Start Function

The auto start function allows operating the compressor optionally in automatic or semi-automatic mode by turning the selector switch.

Semi-automatic operation:

Start the compressor by pushing the Start button. The compressor automatically shuts off when final pressure is reached. To restart the compressor, push the Start button again. The unit can be shut down at any time during operation by pushing the Stop button.



Selector switch auto start function

Automatic operation:

Start the compressor only once by pushing the Start button. The Start button lights up and the unit automatically shuts off when final pressure is reached. If outlet pressure decreases below the selected minimum pressure, the unit automatically restarts.



Note

The compressor can not be manually started during automatic operation.

To enable a manual start, shut off automatic operation by pushing the Stop button (Start button lamp goes out). Now turn selector switch to semi-automatic mode and start the compressor with the Start button.

Adjust re-start pressure (minimum filling pressure)

The pressure switch for start pressure is located after the pressure maintaining valve. The pressure can be adjusted with the upper adjusting screw.

Increasing re-start pressure: turn adjusting screw clockwise

Reducing re-start pressure: turn adjusting screw anti-clockwise

Adjust pressure switch in steps of a quarter turn. Check settings after every adjustment step.

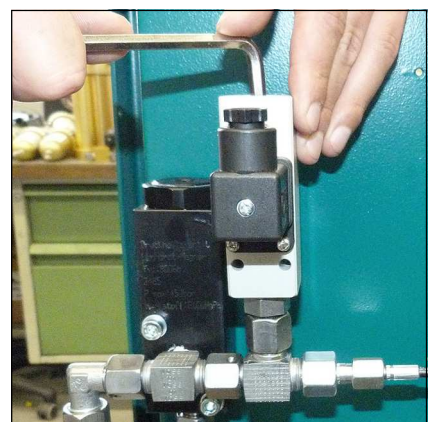

Adjust re-start pressure

AUTO START FUNCTION

Filling procedure semi-automatic operation



Caution! Only fill cylinders which:

- are marked with the test mark and the test stamp of the expert.
- have been hydro static tested (check last test date).
- are rated for the final pressure.
- are free from humidity.



Note

The unit shuts down when final pressure is reached. Thus, the unit always has to be restarted manually.

1. Turn selector switch to semi-automatic mode.
2. Close all filling valves.
3. Connect closed compressed air cylinders.
4. Open filling valves.
5. Start compressor by pushing the ON button.
6. When filling pressure gauge increases, open filling valves slowly.
7. Fill compressed air cylinders to the desired pressure, subsequently close filling valves slowly.
8. Close and vent all filling valves.
9. Disconnect all compressed air cylinders from filling valves.

AUTO START FUNCTION

Filling procedure automatic operation



Caution! Only fill cylinders which:

- are marked with the test mark and the test stamp of the expert.
- have been hydro static tested (check last test date).
- are rated for the final pressure.
- are free from humidity.



Note

The unit shuts down when final pressure is reached. Thus, the unit always has to be restarted manually.

1. Turn selector switch to automatic mode.
2. Close all filling valves.
3. Connect closed compressed air cylinders.
4. Open filling valves.
5. Start compressor by pushing the ON button.
6. When filling pressure gauge increases, open filling valves slowly.
7. Fill compressed air cylinders to the desired pressure, subsequently close filling valves slowly.
8. Close and vent all filling valves.
9. Disconnect all compressed air cylinders from filling valves.
10. If automatic operation is interrupted by:
 - pushing the OFF button
 - turning the selector switch
 - tripping the emergency shut-off switch
 - opening of the doors or the coverthe unit has to be restarted.



AUTO START FUNCTION

Spare part lists

Best.-Nr. / Order No.	Benennung	Description
000203	Druckschalter 50-350 bar	Pressure Switch 50-350 bar
000652	Manometer 0-400 bar	Pressure Gauge 0-400 bar
000794	T-Verschraubung mit fester Mutter	T-Connection with fixed nut
001440	Hochdruckschlauch 10L (1500mm)	High Pressure Hose 10L (1500mm)
005812	Manometerverschraubung	Pressure Gauge Connection

D

AUTO START FUNCTION

Spare part lists

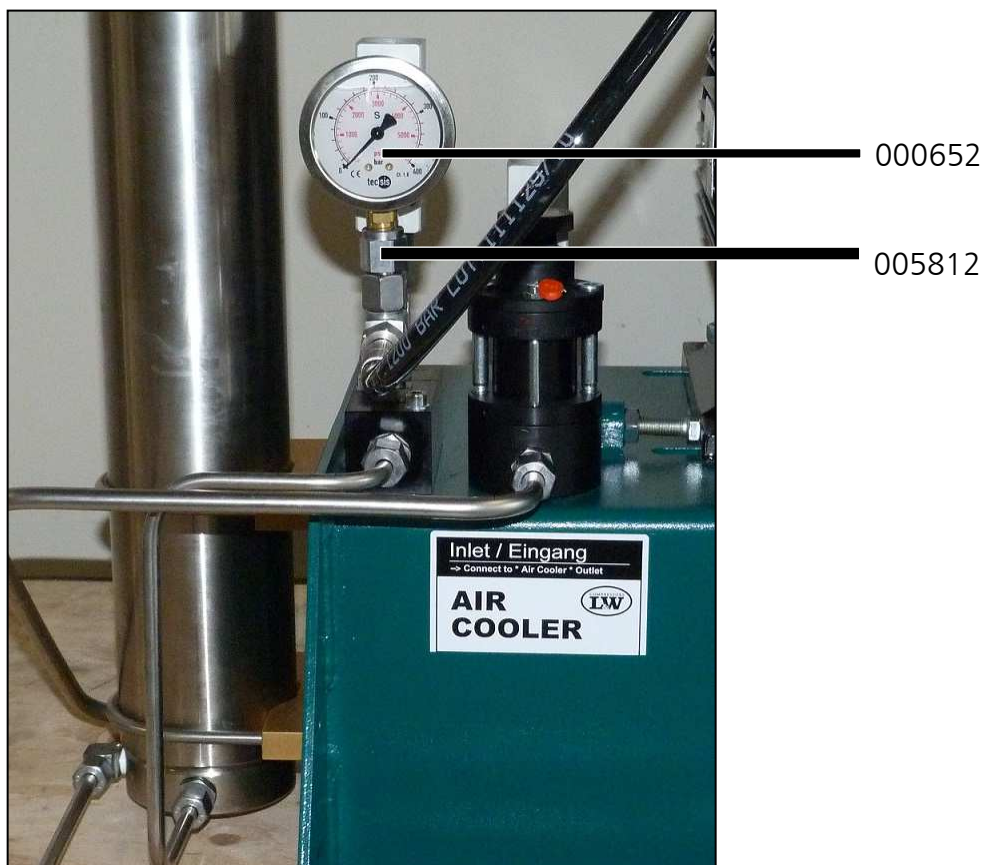
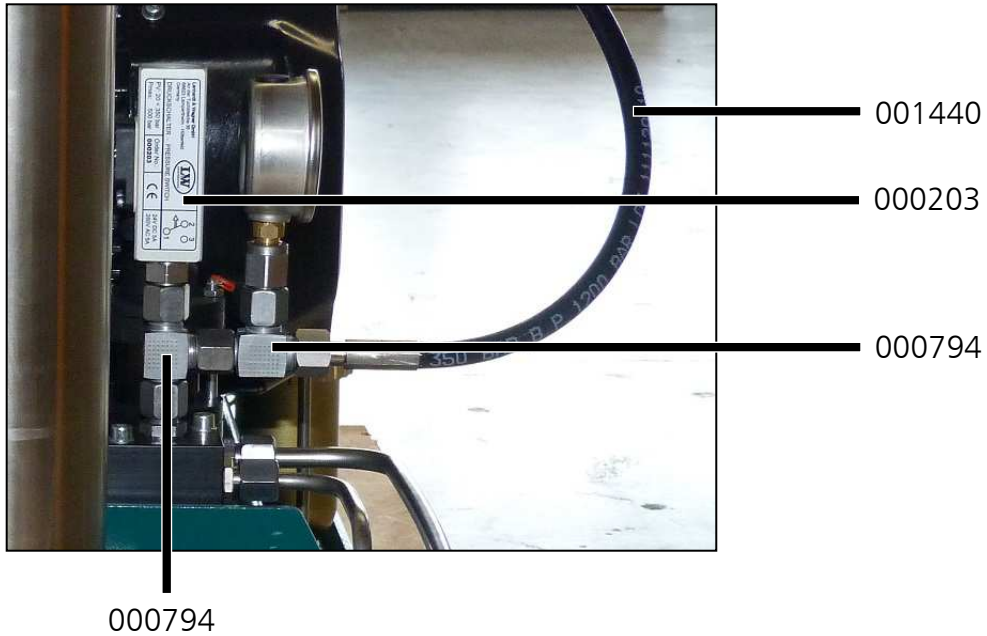

D



OIL PRESSURE GAUGE

D

OIL PRESSURE GAUGE

Oil pressure gauge

The oil pressure gauge shows the compressor oil pressure during operation. Oil pressure values at operating temperature should remain between:

- min. + 1.3 bar
- max. + 1.5 bar

If oil pressure value stays below the minimum value:

- Wrong compressor rotation direction (see rotation direction arrow)
- Oil level too low, not enough oil in the compressor
- Oil pump sieve contaminated
- Oil intake hose damaged / defective
- Oil temperature below +5 °C - lubrication not possible
- Oil temperature higher than +120 °C - oil viscosity too low
- Oil pump defective

If oil pressure value stays above the maximum value:

- Low oil temperature, between +5 °C and +10 °C
- Should stay within the range of tolerance when operation temperature is reached..

Oil pressure control

If oil pressure remains outside the range of tolerance, it can be adjusted at the oil pump.

Increasing oil pressure

- Turn adjusting screw clockwise

Reduce oil pressure

- Turn adjusting screw anti-clockwise



Warning

Only adjust the oil pressure at operating temperature!

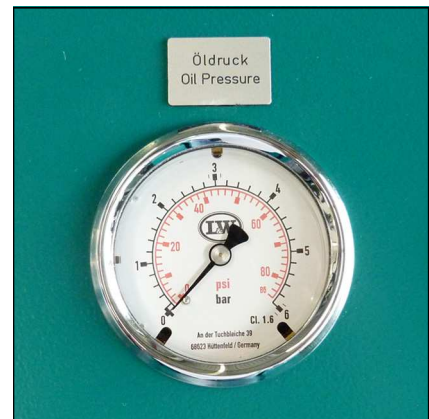

Oil pressure gauge

D



Adjusting the oil pressure

OIL PRESSURE GAUGE

Spare part lists

Best.-Nr. / Order No.	Benennung	Description
000655	Öldruckmanometer	Oil Pressure Gauge
004169	Manometerschlauch	Hose for Pressure Gauge

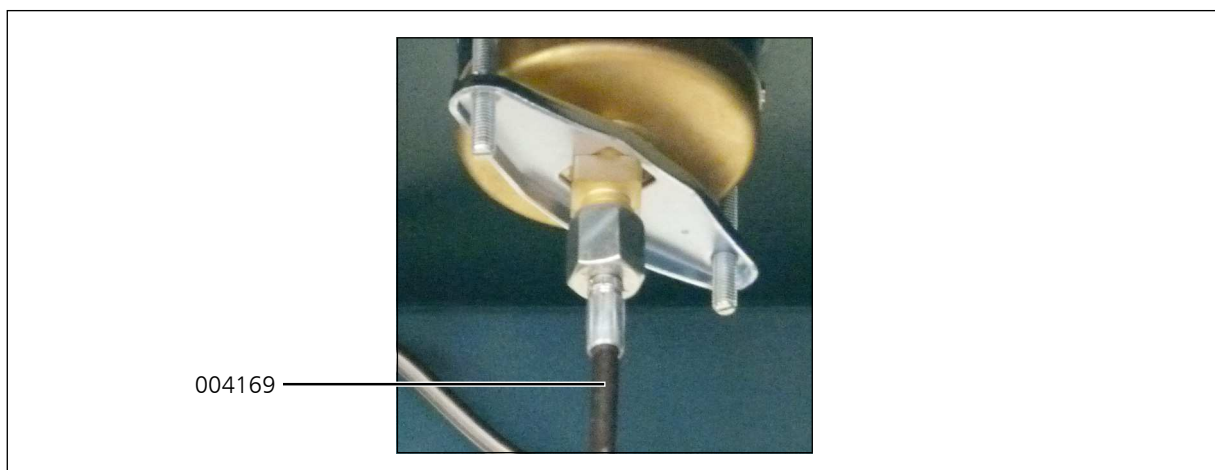
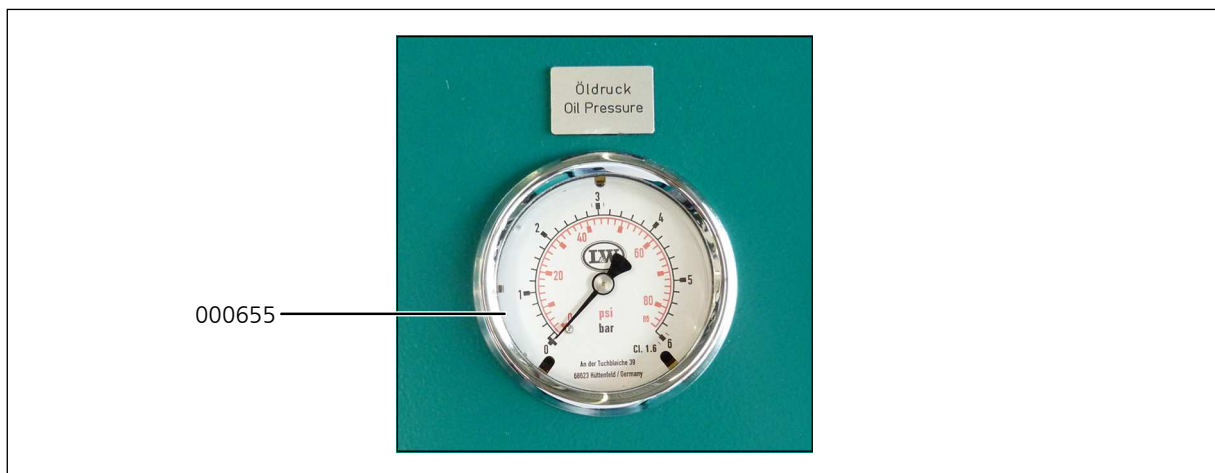



OIL PRESSURE MONITORING

D

OIL PRESSURE MONITORING

Oil pressure monitoring

The oil pressure is maintained by a pressure switch during operation. The compressor automatically shuts off when oil pressure decreases below the minimum pressure of +0.5 bar. The red warning lamp "Oil Pressure Monitoring" lights up.

Possible causes of fault:

- Wrong compressor rotation direction
(see rotation direction arrow)
- Oil level too low, not enough oil in the compressor
- Oil pump sieve contaminated
- Oil intake hose damaged / defective
- Oil temperature below +5 °C - lubrication not possible
- Oil temperature higher than +120 °C - oil viscosity too low
- Oil pump defective



Oil Pressure Monitoring



OIL PRESSURE MONITORING

Spare part lists

Best.-Nr. / Order No.	Benennung	Description
004701	Warnlampe	Warning Lamp
004703	Schild	Label
004704	Relais für Warnlampe	Relais for warning lamp
005261	Öldruckschalter	Oil Pressure Switch
005482	Halteblech Öldruckschalter	Bracket Oil Pressure Switch
005483	Rohrleitung	Pipe
006859	Schildträger	Label holder

D

OIL PRESSURE MONITORING

Spare part lists

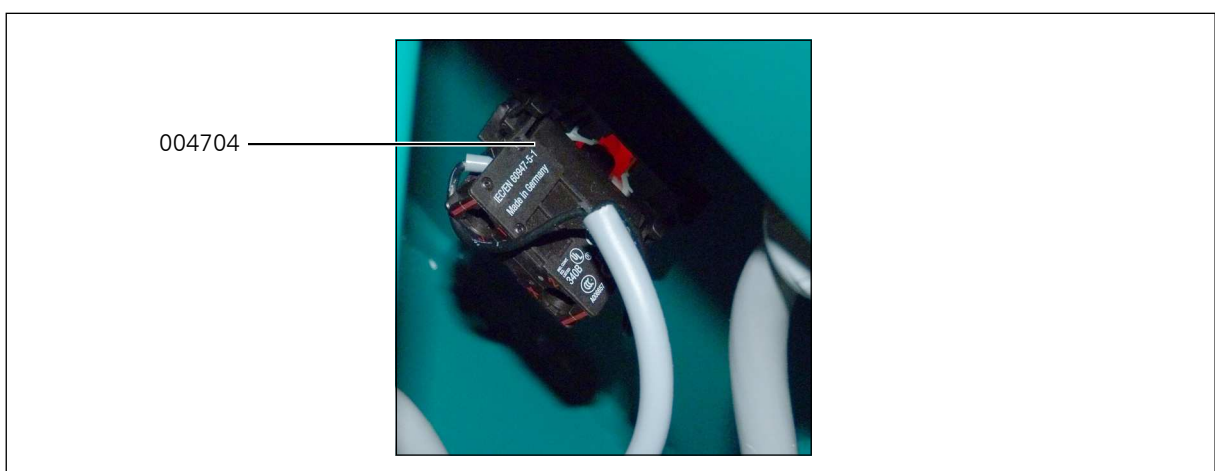
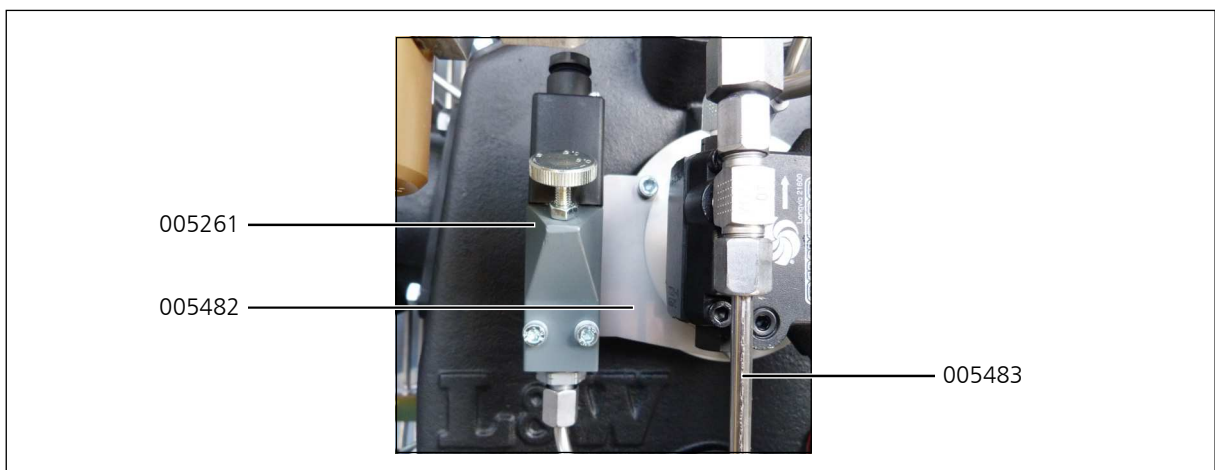

D



OIL PRESSURE MONITORING

Baugruppe: Öldrucküberwachung / Assembly: Oil Pressure Monitoring

Best.-Nr. / Order No.	Benennung	Description
000712	Verschraubung GE06LR1/4CFX	Connection GE06LR1/4CFX
000716	Verschraubung TE G1/8" / 6L	Connection TE G1/8" / 6L
000732	Mutter 06L	Nut 06L
000733	Schneidring SR 06	Olive Seal SR 06
001021	Zylinderschraube M5x40 mm DIN912 8.8 ZN	Allen Bolt M5x40 mm DIN912 8.8 ZN
001151	Mutter M5 DIN934 ZN	Nut M5 M5 DIN934 ZN
001176	U-Scheibe A5 DIN125 ZN	Washer A5 DIN125 ZN
002395	Verschlusskegel 06mm	Locking cone 06mm
005482	Halblech Öldruckschalter	Bracket Oil Pressure Switch
005483	Rohrleitung Ø6mm, Edelstahl	Pipe Ø6mm, s/s
005484	Minimessschlauch 5000mm	Pressure Gauge Hose 5000mm

D

OIL PRESSURE MONITORING

Baugruppe: Öldrucküberwachung / Assembly: Oil Pressure Monitoring

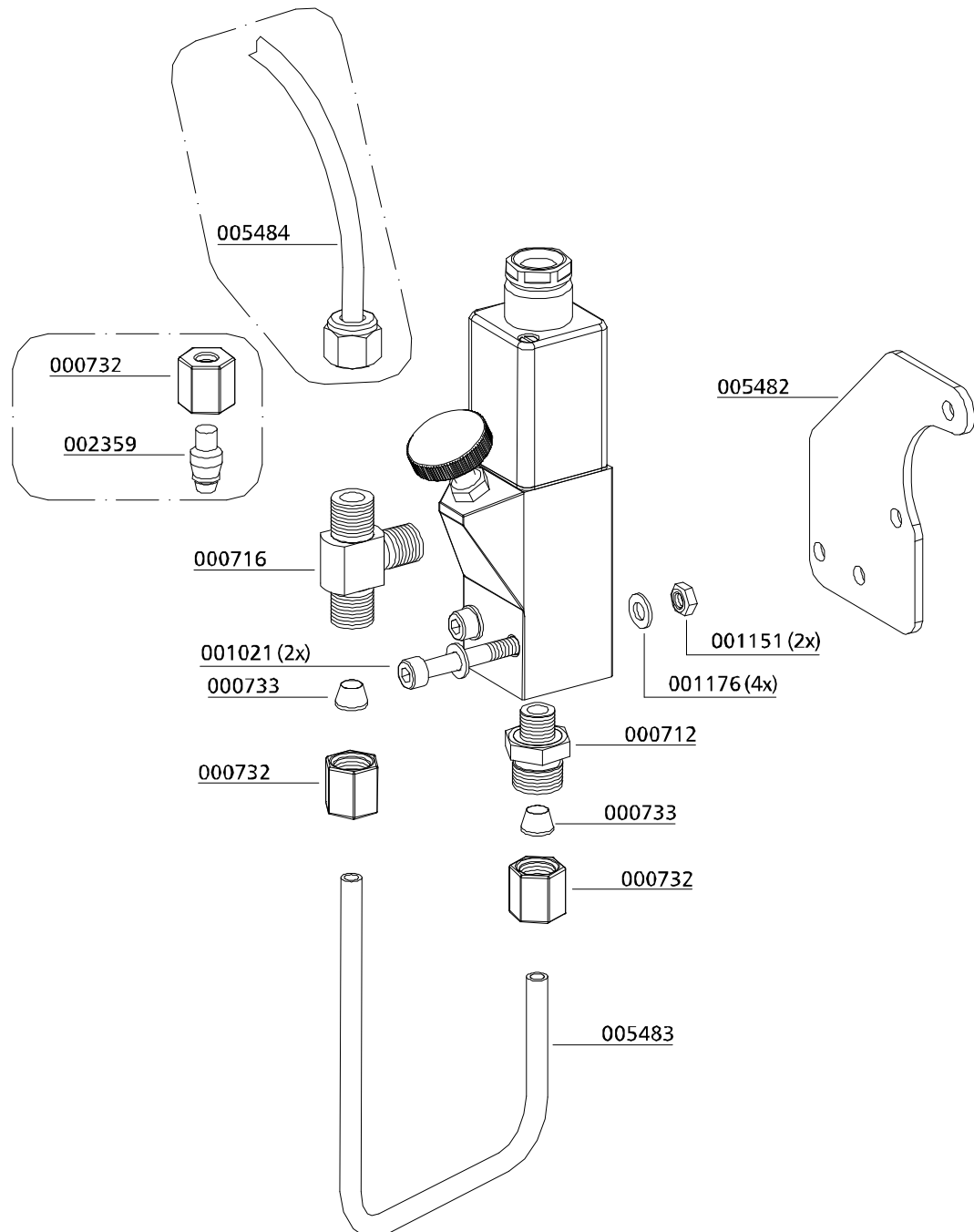

D



OIL TEMPERATURE MONITORING

D

OIL TEMPERATURE MONITORING

Oil temperature monitoring

Oil temperature monitoring

The oil temperature is maintained by a temperature sensor inside the compressor block during operation.

The compressor automatically shuts off when oil temperature exceeds the maximum pressure of +100 °C. The red warning lamp "Oil Temperature Monitoring" lights up.

Possible causes of fault:

- Ambient temperature too high
- Cooling air flow not sufficient
- Oil level too low
- Cooling pipes contaminated



Oil Pressure Monitoring



Warning

Risk of burns!

Allow the unit to cool before beginning troubleshooting.

OIL TEMPERATURE MONITORING

Spare part lists

Best.-Nr. / Order No.	Benennung	Description
004342	Display	Display
004730	Display und Sensor	Display and Sensor

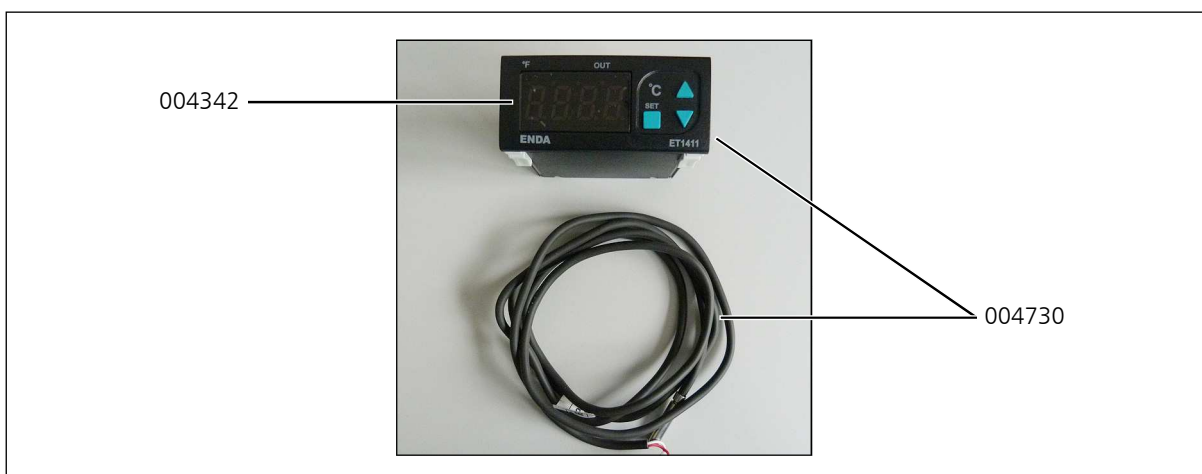

D



CYLINDER HEAD TEMPERATURE MONITORING

D

CYLINDER HEAD TEMPERATURE MONITORING

Cylinder head temperature monitoring

The cylinder head temperature is maintained by a temperature sensor at the cylinder head of the high pressure stage during operation. The compressor shuts off automatically when cylinder head temperature exceeds the maximum pressure of +120° C. The red warning lamp "Cylinder Head Temperature Monitoring" lights up.

Possible causes of fault:

- Ventilation of the compressor room is not sufficient
- Cooling air flow not sufficient
- Cooling pipes contaminated



Warning

Risk of burns!

Allow the unit to cool before beginning troubleshooting.

CYLINDER HEAD TEMPERATURE MONITORING

Spare part lists

Best.-Nr. / Order No.	Benennung	Description
004726	Display	Display
005585	Sensor	Sensor
007613	Ventilkopf (Spezielle Version)	Valve Head (special version)

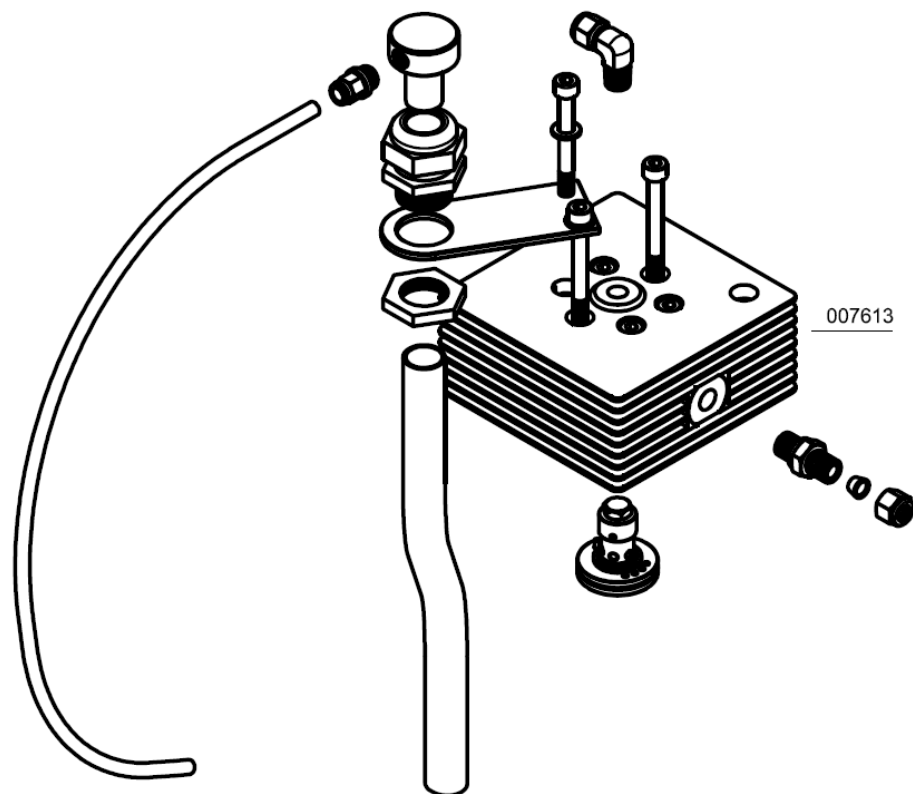
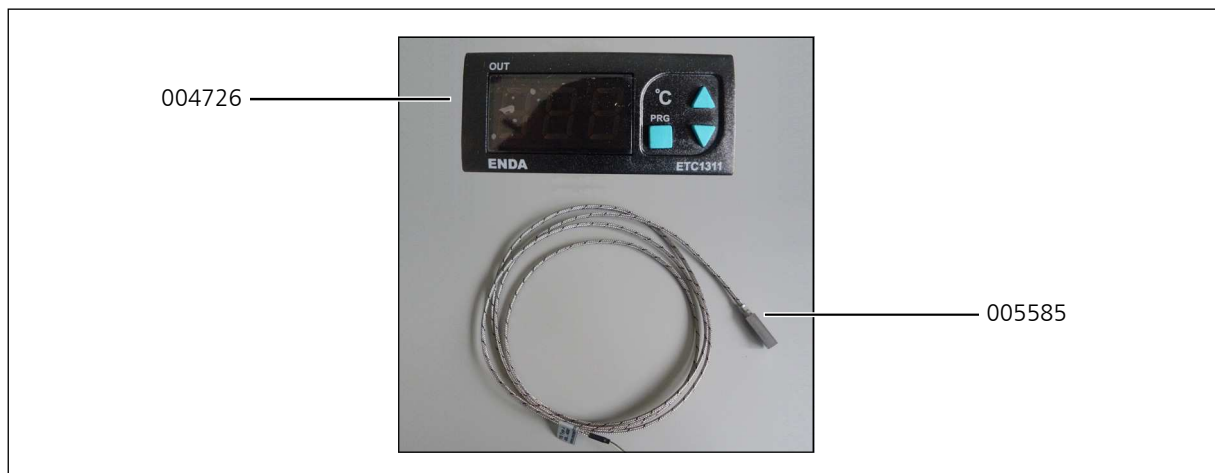

D



INTERSTAGE PRESSURE GAUGES

D

INTERSTAGE PRESSURE GAUGES

Interstage pressure gauges

Each of the 3 pressure stages is monitored by a single pressure gauge. This is serviceable for troubleshooting and allows detecting faults at an early stage.

Indicated interstage pressures depend on final pressure settings.

The pressure gauges should show the following values at a final pressure of 300 bar:

1. 3rd stage: approx. 4.2 bar
2. 3rd stage: approx. 42 bar
3. 3rd stage: approx. 300 bar

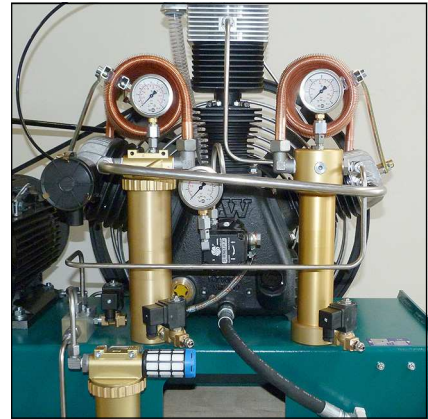

Interstage pressure gauges

INTERSTAGE PRESSURE GAUGES

Spare part lists

Best.-Nr. / Order No.	Benennung	Description
000645	Manometer 1. Stufe	Pressure gauge 1st stage
000648	Manometer 2. Stufe	Pressure gauge 2nd stage
000710	Gerade Verschraubung	Straight Connection
000769	Manometerverschraubung	Gauge connection

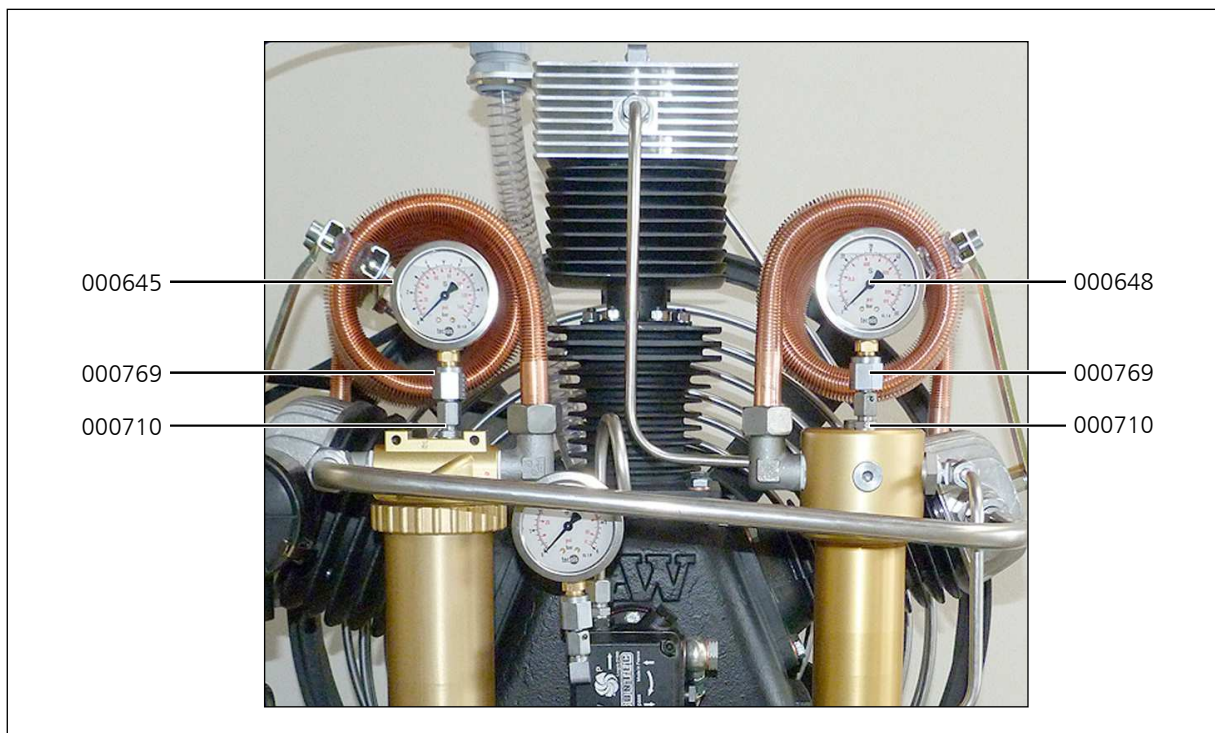



**200 / 300 BAR
PARALLEL FILLING
PRESSURE OPERATION**

D

200 / 300 BAR PARALLEL FILLING PRESSURE OPERATION

200 bar / 300 bar parallel filling pressure operation

This option allows the filling of 200 bar and 300 bar at once.

In this case, the compressor is equipped with a pressure reducer, a second final pressure safety valve and a second filling pressure gauge.

The handwheels (or bellows) are colour-coded to allow an optical differentiation:

- 200 bar: black
- 300 bar: red

Furthermore, the corresponding filling pressures at the compressor are marked with labels.



DIN handwheels 200 bar and 300 bar



Fig. Safety valve: 225 bar (left),
pressure reducer: 330 / 225 bar (right)

Füllschlauch / Filling Hose

Best.-Nr. / Order No.	Benennung	Description
001440	Hochdruckschlauch 10L, 1500 mm, starr	HP-Hose 10L 1500 mm, fixed

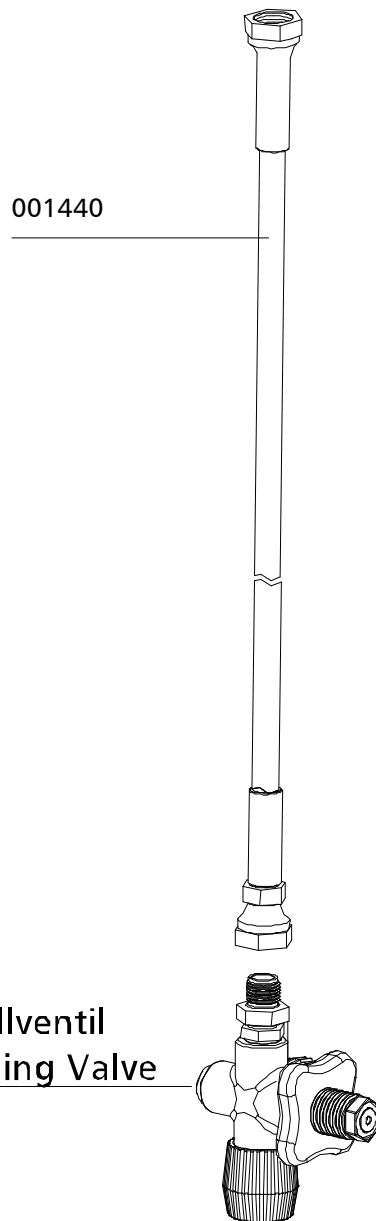

D



200 / 300 BAR PARALLEL FILLING PRESSURE OPERATION

Füllventil mit Manometer / Filling Valve with Pressure Gauge

Best.-Nr. / Order No.	Benennung	Description
000213	Handrad, schwarz, 200/232 bar DIN, G 5/8"	Hand Wheel DIN 200 bar, black, G 5/8"
000215	Handrad rot, 300 bar DIN	Hand Wheel DIN 300 bar, red
000386	Gleitscheibe, Kreuzventil	Slide Washer
000387	Feder, Kreuzventil	Coil Spring, cross d. valve
000666	Manometerschutzkappe Ø63mm	Protector Pressure Gauge Ø63mm
000696	Füllanschluss o. Handrad, Messing verchr., 200 bar, AG M16x1,5	Filling Connect. w/o handwheel. 200 bar, AG M16x1,5
000697	Füllanschluss o. Handrad, ab 2005, 300bar,AG M16X1,5 für Schlauch	Filling Connec. w/o handwheel, 300bar, AG M16X1,5 hose
000709	Füllventil Kreuzbauweise, v2 x G1/4" IG, 1 x M16 x 1,5mm IG	Filling Valve cross design
000785	Verschraubung konisch, GE 10L R1/4"	Connection conical, GE 10L R1/4"
001237	O-Ring DIN Flaschenanschluss 200/300bar, 12,37x2,62 NBR90	O-Ring DIN filling connector 200/300bar, 12,37x2,62 NBR90
001391	O-Ring, Kreuzventil	O-Ring, / Cross design Filling Valve
001392	Füllhandrad Kreuzventil Ø35mm	Hand Wheel Filling Valve cross Ø35mm
001393	Entlüftungsspindel	Vent Spindle
001394	Entlüftungshandrad Ø27mm	Vent Hand Wheel Ø27mm
001395	Gleitscheibe, schwarz, Kreuzventil	Slide Washer, plastic black
001397	Kupferdichtung 8 x 14 x 1mm	Copper Seal Ring 8 x 14 x 1mm
001398	Madenschraube M3x8mm	Worm Screw M3x8mm
001399	Adapterwelle, Kreuzventil	Adapter Shaft
001400	Dichtspindel, Kreuzventil	Seal Spindle Filling Valve
001401	Schlitzmutter	Slotted Nut
001402	Klemmverschraubung, kompl. mit O -Ring	Filling Spindle Body, c/w O-rings
004977	Manometer, Edelstahl	Pressure Gauge, S/S

D

200 / 300 BAR PARALLEL FILLING PRESSURE OPERATION

Füllventil mit Manometer / Filling Valve with Pressure Gauge

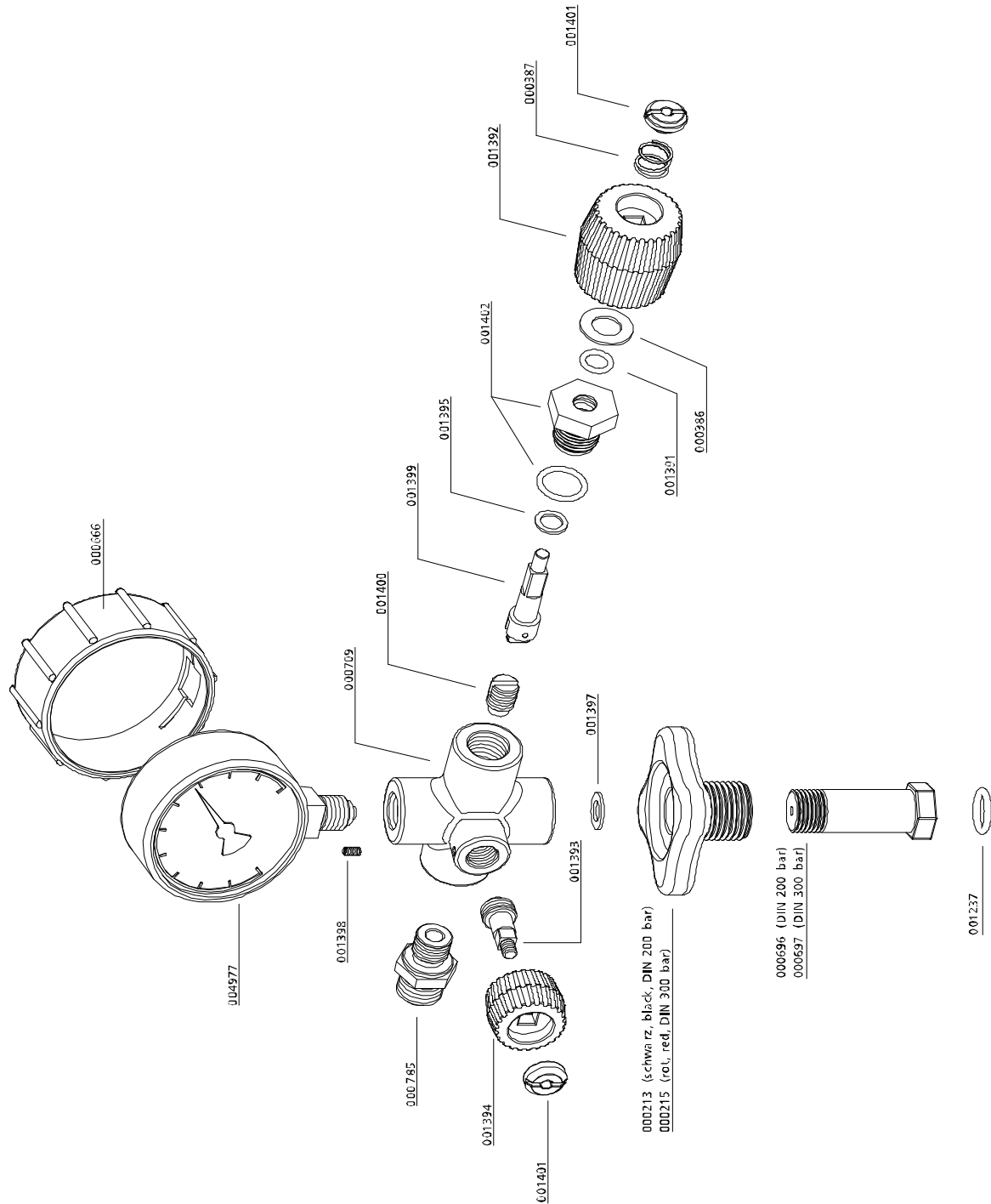

D



200 / 300 BAR PARALLEL FILLING PRESSURE OPERATION

Baugruppe: Verteilerblock / Assembly: Distributor Block

Best.-Nr. / Order No.	Benennung	Description
000210	Verteilerblock, Al, 2 Druckbereiche	Distributor Block, alloy, dual pressure
000498	Unterlegscheibe A6	Washer A6
000710	Verschraubung ohne Mutter &	Connection w/o nut& olive seal,
000721	Verschraubung WE 06 PLR CFX 1/4"	Connection WE 06 PLR CFX 1/4"
000732	Mutter M06LCFX	Union Nut M06LCFX
000733	Schneidring SR06	Olive Seal SR06
000738	Verschraubung GE 08 PLR1/4"	Connection GE 08 PLR1/4"
000750	Verschraubung, EVGE 08 PSR-ED / G1/4	Connection with fixed nut, EVGE 08 PSR-
000761	Verschraubung WE 08 PLR CFX 1/4"	Elbow connection WE 08 PLR CFX 1/4"
000765	Schneidring PSR 08 LX	Olive Seal PSR 08 LX
000767	Mutter M08 S A3C	Nut M08 S A3C
000838	Verschlussstopfen VSTI R1/4" EDCFX	Plug VSTI R1/4" EDCFX
001048	Zylinderschraube M6x10 DIN 912 8.8 ZN	Allen Screw M6x10 DIN 912 8.8 ZN
001428	Druckminderer "High Flow" einstellbar	Pressure reducer - bolt version
003182	Rohrleitung	Pipe
004932	Verschraubung MAV 1/4"NPT / 8S, für	Connection MAV 1/4"NPT / 8S, for

D

200 / 300 BAR PARALLEL FILLING PRESSURE OPERATION

Baugruppe: Verteilerblock / Assembly: Distributor Block

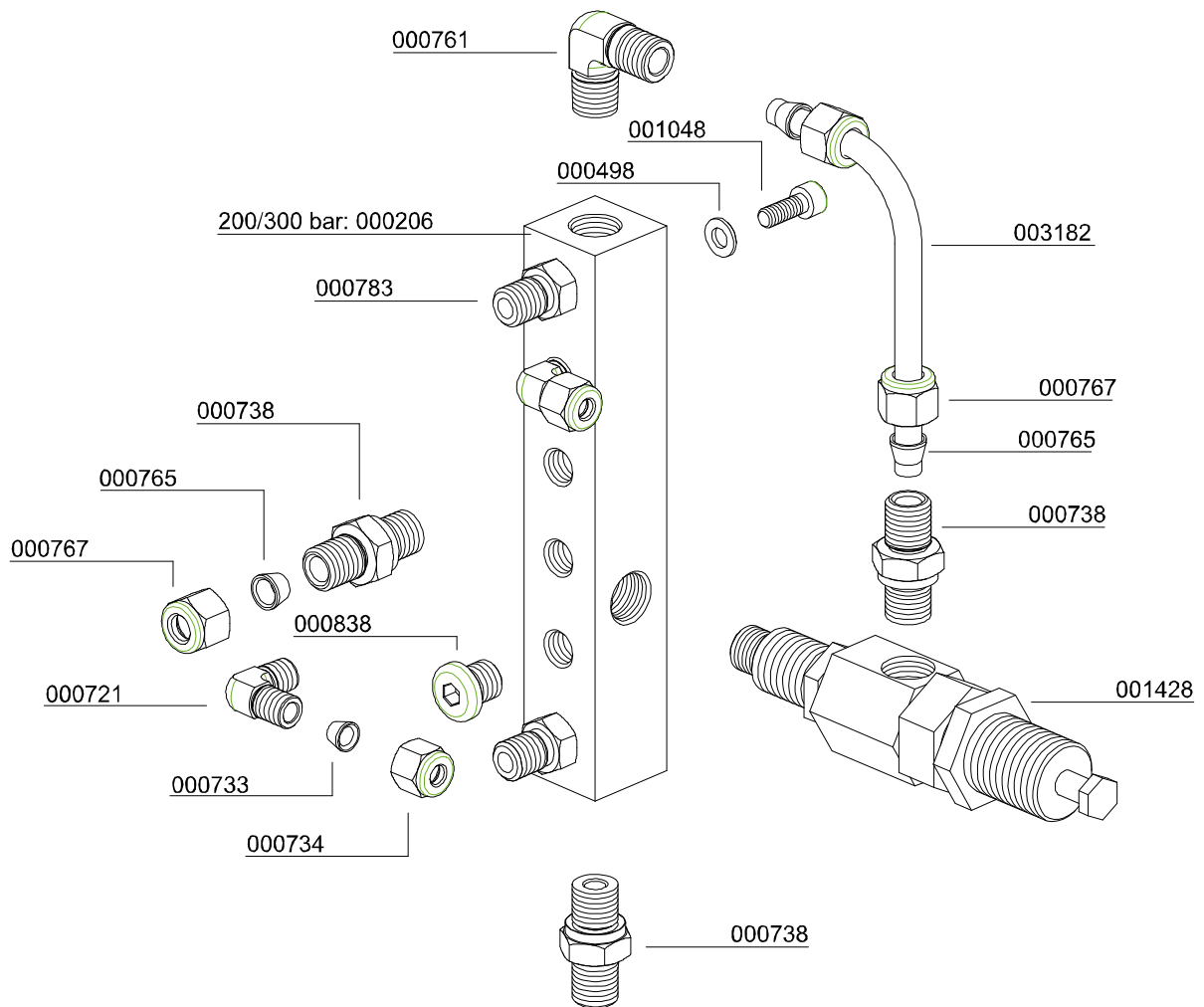

D



AIR COOLER CONNECTION KIT

D

AIR COOLER CONNECTION KIT

Air cooler connection kit

The Air Cooler Connection Kit provides an easy connection and a simple and time-saving installation or backfitting.

The piping inside the compressor is completely installed. Just disconnect the U-connection at the outside and connect the air cooler according to the connection designation (inlet/outlet).

To operate the unit without air cooler, reinstall the U-connection and the compressor is ready for use.

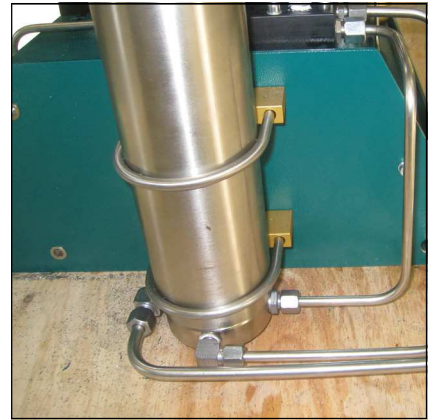

Air cooler connection kit

AIR COOLER CONNECTION KIT

Spare part lists

Best.-Nr. / Order No.	Benennung	Description
000783	Gerade Verschraubung	Straight Connection
000796	Winkelverschraubung	Elbow Connection
006928	Rohrleitung	Connecting Pipe

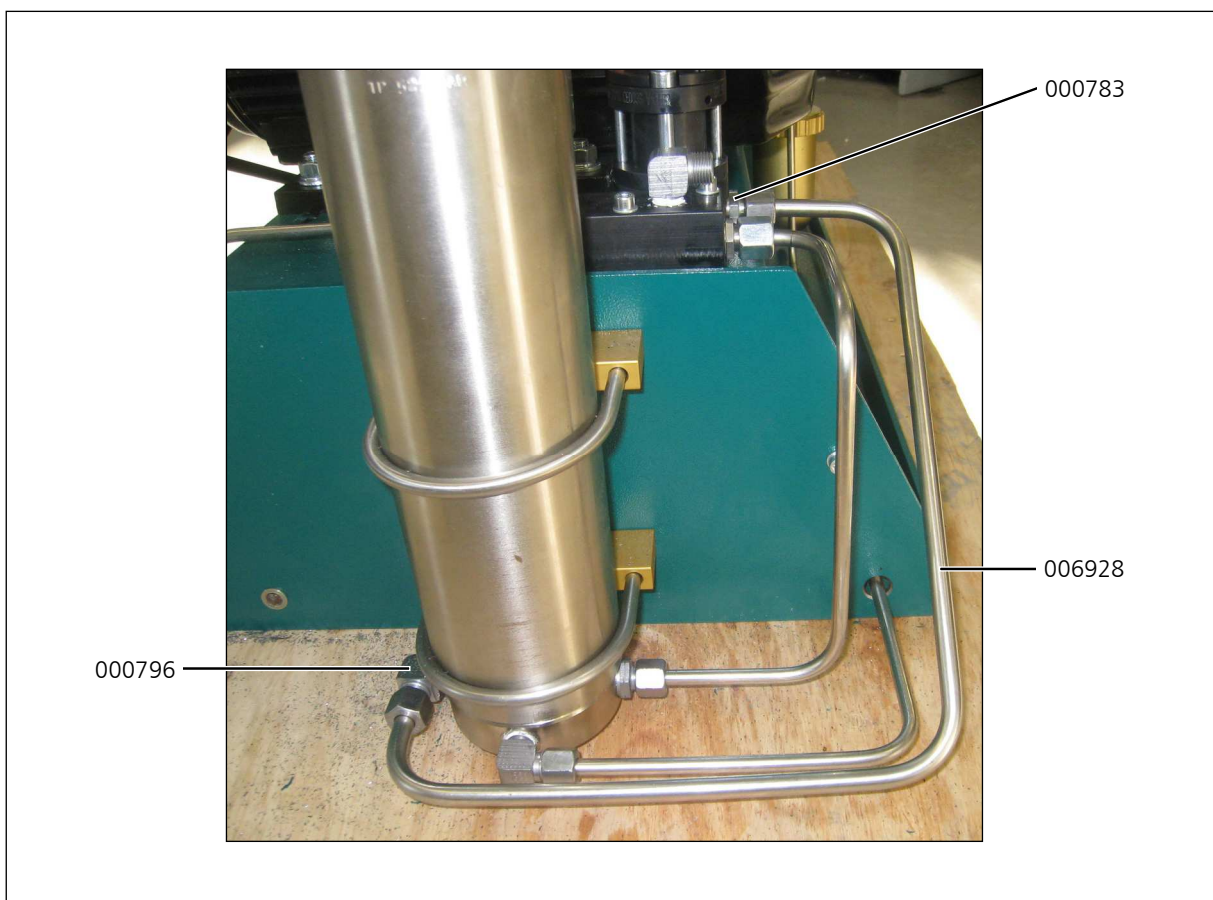

D



CONDENSATE TANK 60 LTR.

D

CONDENSATE TANK 60 LTR.

The 60 ltr. tank is equipped with an active carbon filter to collect condensate odourlessly and quietly. The condensate can be easily transported in the collecting tank and disposed environmentally sound.

The flexible connection hoses are fitted with quick-couplings, to allow easy separation from the compressor. The tank is equipped with a level gauge to indicate max. filling level. Two sturdy carrying handles ensure a safe transportation.

Technical Data:

- Dimensions: Ø 400 mm x 800 mm
- Weight: 20 kg



D

CONDENSATE TANK 60 LTR.

Maintenance and service

How to change the activated carbon and the metal filter insert

- Shut down the unit
- Plug out the condensate hoses
- Remove the protector cap, the nut and the allen bolts (Fig. 1)
- Take down the cover plate and the upper felt. Tip out the activated carbon and replace the lower felt
- Fill up the activated carbon and cover it with a new felt
- Put on the cover plate, screw the allen bolts and the nut and plug on the protector cap
- Unscrew the filter housing
- Remove the floater and the lower cover plate (Fig. 2)
- Take a pliers and pull the metal filter out of the metal case
- Insert the metal filter
- Install the cover plate and the floater
- Screw the filter housing onto the tank
- Plug in the condensate hoses

Maintanance intervals

We recommend to change the activated carbon if it has reached the saturation level (smell of oil).

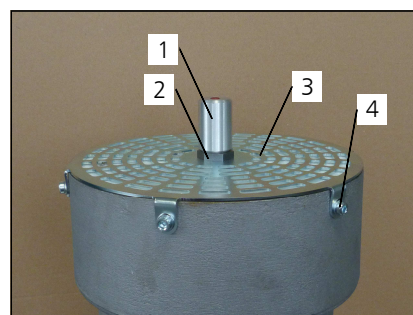

Fig. 1
1 Protector cap
2 Nut
3 Cover plate
4 Allen bolts (6x)

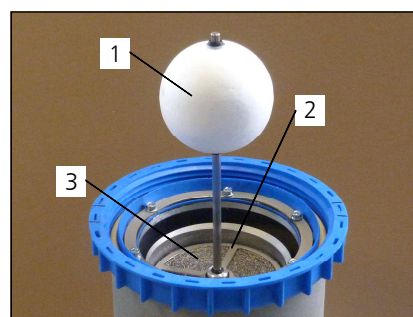

Fig. 2
1 Floater
2 Lower cover plate
3 Metal filter

CONDENSATE TANK 60 LTR.

Spare part lists

Best.-Nr. / Order No.	Benennung	Description
003091	Kondensatbehälter 60 Liter	Condensate Tank 60L
004056	Kondensatschläuche Kondensatbehälter 60L, für 3-	Set of condensate hoses, 3 stages
004057	Kondensatschläuche Kondensatbehälter 60L, für 4-	Set of condensate hoses, 4 stages

D

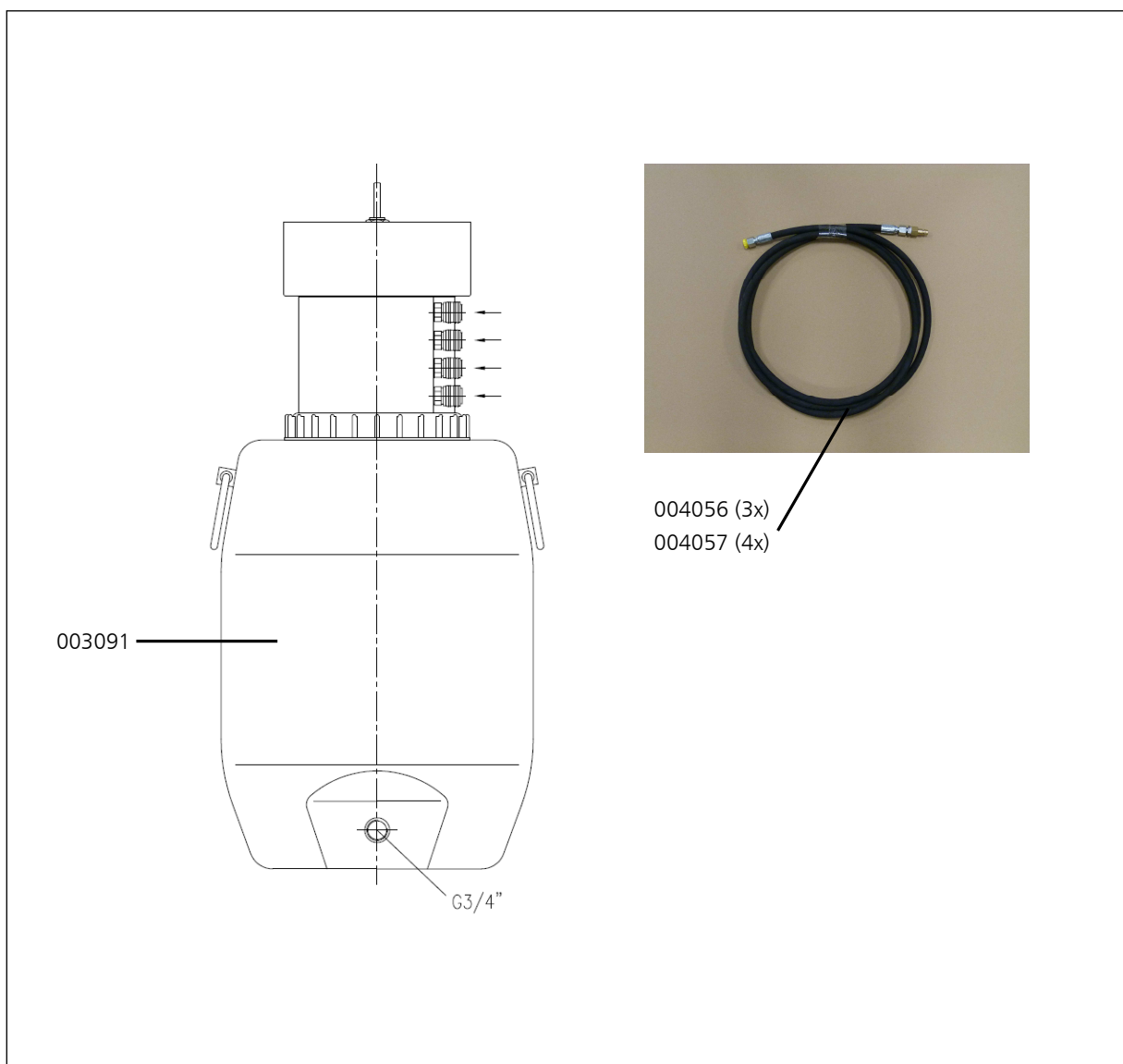

CONDENSATE TANK 60 LTR.

Spare part lists

Best.-Nr. / Order No.	Benennung	Description
000508	USIT-Ring 13,7 x Ø20 x 1,5	Gasket Ring U-Sit 13,7 x Ø20 x 1,5
003866	Filter Nachfüllset für 60 Liter	Filter refill set 60 ltr
004789	Schnellkupplung G1/4", DN 7,2	Quick connector G1/4", DN 7,2
006642	Metallgestrick für Kondensatbehälter 60 ltr	Metal filter insert 60 ltr tank

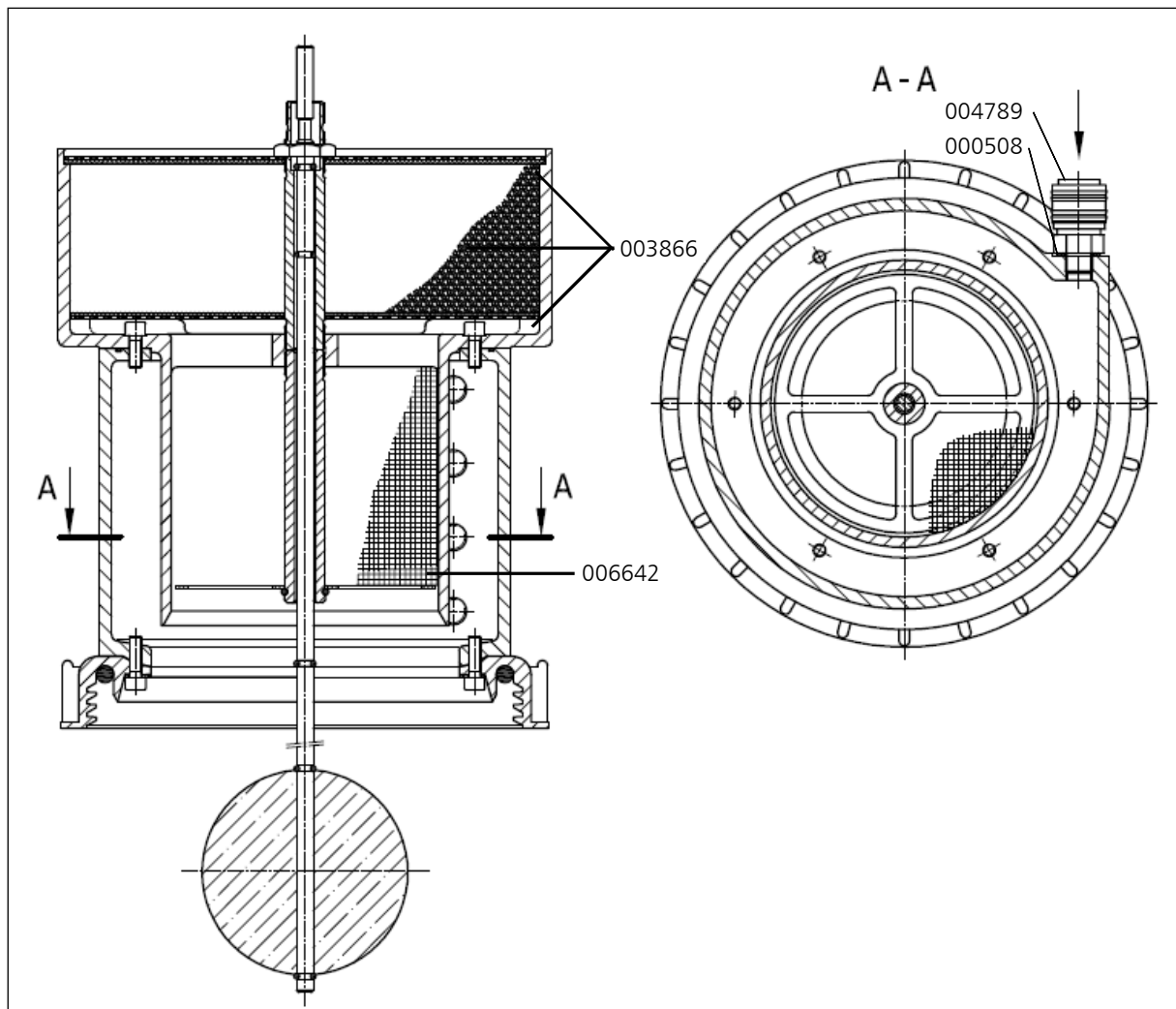

D



ATTACHMENT

E

Lenhardt & Wagner GmbH

**An der Tuchbleiche 39
D-68623 Lampertheim – Hüttenfeld**

www.lw-compressors.com



Operating Instruction

Safety valve

Typ:

SiV2 BKZ 989 TÜV.SV.12-989.5.G.V.P CE 0091 AlMgSi1 F31 1100* Lenhardt & Wagner

SiV BKZ TÜV.SV.14-1140.5.G.V.p CE 0091 AlMgSi1 F31 1100* Lenhardt & Wagner

Set pressure:	see mark (hand wheel on top of valve)
Maximum outflow:	Set pressure 100-159 bar: 750 l / min Set pressure 160-350 bar: 1.100 l / min
Suitable media:	Media-resistant, non-corrosive gases

The safety valve is used for protection of pressurized components, eg pipelines, pressure vessels, or the compressor itself.

The hand wheel on the top of the safety valve is marked with the adjusted set pressure.



- 1) **Identification of set pressure**
- 2) **Seal**
- 3) **Fixing screws¹**
- 4) **Venting screw (hand wheel)**
- 5) **Identification serial number**
- 6) **Socket for safety valve**

Safety valve with socket

¹ und die Anforderungen des AD 2000 Merkblatts W7 erfüllen. Schaftlänge 70mm. The fixing screws M8 must be strength class 8.8 and meet the requirements of Merkblatt AD 2000 leaflet W7. Shaft length 70mm.

In order to prevent manipulation of the set pressure, all safety valves are factory fitted with a seal.

A safety valve on which the seal has been removed, must be returned before further use to the manufacturer for repair / adjustment.

In addition, the safety valve has a venting device (hand wheel).

In the rotation direction clockwise, the safety valve and herewith also the filter housing of the final stage could be completely vented.

During normal operation, the screw is unscrewed to the upper stop anticlockwise, an integrated safety ring prevents that the screw can be completely unscrewed.

If a safety valve blow off, the system must be switched off immediately and investigate the cause of the error.

There are two possible reasons:

1. The safety valve is defective and blows off before the set pressure.

In this case the safety valve should be submitted immediately to the manufacturer for repair or replaced with a new one.

2. The safety valve opens properly, the problem is on the system.

A constant blowing of the safety valve is not permitted, the sealing seat of the valve can be damaged. The error on the system must be detected and repaired before further filling operations.

The safety valve may only be used if it is ensured that the maximum flowrate of the system does not exceed the blowoff rate of the safety valve.

The safety valve may only be used with the approved media.

Repair work on compressors must only be performed by trained personnel.

Dismantling of the safety valve

Ensure that on the safety valve is no pressure.

Loosen and remove the two M8 fixing bolts with a 6mm Allen key.

The safety valve can now be removed by turning and simultaneously pulling out of the socket.

Mounting

1. Clean the safety valve socket.

2. Oil the insert pin of the safety valve including the O-ring with 1 to 2 drops of oil.

3. Press the safety valve pin complete into the socket.

4. Fasten the safety valve with the two 8 mm allen screws into the socket

(Tightening torque: 10 Nm)

5. Screw the venting screw (hand wheel) anticlockwise to its upper limit.

6. Start the System (Compressor), check installation for leaks and proper function.

Manufacturer: Lenhardt & Wagner GmbH
An der Tuchbleiche 39
D-68623 Lampertheim – Hüttenfeld

Kontakt: E-Mail: service@lw-compressors.com
Web: www.lw-compressors.com
Tel.: +49 (0) 6256 – 85880 0
Fax: +49 (0) 6256 – 85880 14

Note:

*Use the safety valve only in a technically perfect condition, for its intended purpose, safety and danger awareness, in compliance with the operating instructions!
Especially disorders which could affect safety must be remedied immediately!*

Notes:

- The safety valve must be installed directly on the protected pressure vessel and / or the plant.
 - The safety valve must be installed in an upright position.
 - The flow area of the port must be greater than the valve opening.
 - Protect valve against splashes
-

Maintenance:

- The safety valve is periodically - in accordance with the currently valid Pressure Equipment Directives - to check on operation and reliability.
- Refill annually lubricating oil:
Oil filling position:
Hole on the spacer (see arrow, Figure 1)
- Oil level: Fill oil into the hole until oil comes out of the hole.

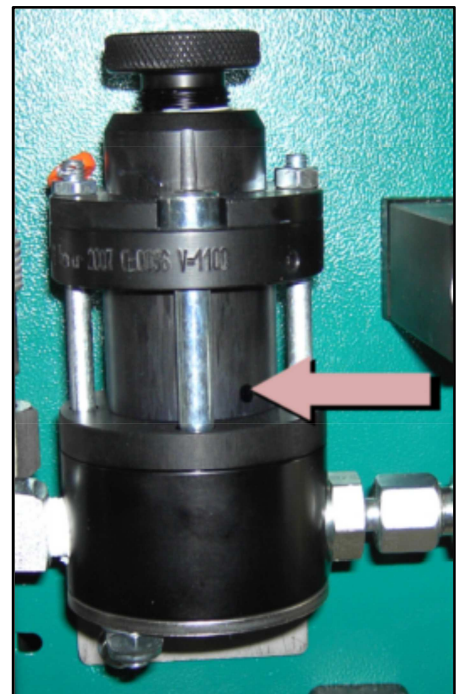

Figure 1: Position for oil refill

To be used lubricating oil for the safety valve: L&W Article Nr.: 008500 (content: 30 ml)
