



## CHAPTER OVERVIEW

---

**Operating Instructions** .....

A

**ECC - Electronic Compressor Control (if equipped)**.....

B

**Spare Parts Lists** .....

C

**Options (if equipped)**.....

D

**Attachment** .....

E

### Manufacturer in terms of 97/23/EC

The full name and address of the manufacturer is:

Lenhardt & Wagner GmbH

An der Tuchbleiche 39

68623 Hüttenfeld / Germany

Phone: +49 (0) 62 56 - 85 88 0 - 0

Fax: +49 (0) 62 56 - 85 88 0 - 14

E-Mail: [service@lw-compressors.com](mailto:service@lw-compressors.com)

Internet: [www.lw-compressors.com](http://www.lw-compressors.com)

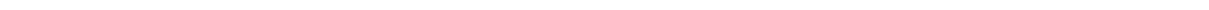



## SERVICE INFORMATION / WARRANTY

---

### Compressor information

\_\_\_\_\_

Type designation

\_\_\_\_\_

Serial number

\_\_\_\_\_

Date of construction

### Purchase information

\_\_\_\_\_

Purchase date

\_\_\_\_\_

First commissioned on

\_\_\_\_\_

Warranty period

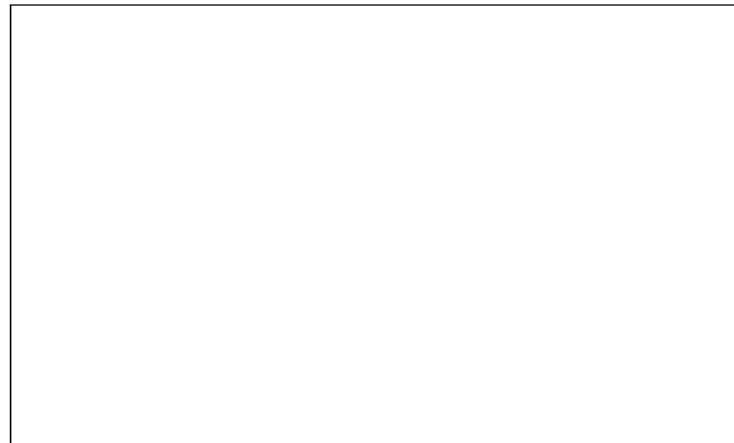

Dealer's stamp

### Warranty

L&W will uphold warranty claims made during a period of 12 months from the invoice date.

If the compressor was purchased from an official L&W dealer, the date on the dealer's invoice is valid. Warranty claims can only be made on presentation of the original invoice.

Should verifiably defective parts have been delivered, we will decide to either replace the parts or repair them. The resulting transport and assembly costs will be invoiced.

No reduction of the purchase price or changes to the contract can be made. The parts for which a claim is being made should be kept safe by the purchaser and, when requested, sent to us at their cost. Replaced parts become the property of L&W. If maintenance work is carried out without our knowledge or permission by the purchaser or a third party, we are absolved from any liability for warranty claims. As a matter of principle, warranty claims can only be made by the initial purchaser.

---

# Operating Instructions

Breathing Air Compressor

LW 700 ES II





## TABLE OF CONTENTS

---

### **General Information & Technical Data**

General Information / Description of Warning Symbols .....	4
Scope of Delivery .....	5
Technical Data .....	6
Technical Data - Overview Operating Noise dB(A).....	7
Over View LW 700 ES II .....	8
Switchboard .....	9
Flow Chart .....	10

### **Safety Precautions**

Intended Use / Operators .....	11
Safety Instructions on the Unit .....	13
General Safety Precautions .....	14
Unit Customised Safety Notices .....	15
Maintenance Instructions .....	16
Transportation Instructions / Safety Regulations .....	17

### **Installation**

Installation in Closed Rooms .....	19
Dimensions .....	20
Minimum Distances .....	21
Ventilation .....	22
Electrical Installation .....	23 - 24

### **Operation**

Important Operation Instructions .....	26
First Commissioning .....	27 - 29
Daily Commissioning .....	30
Filling Procedure .....	31
Switch Off Compressor Unit .....	32

<b>Remedying Faults</b> .....	34 - 37
-------------------------------	---------

### **Maintenance & Service**

Service, Repair and Maintenance .....	39
Maintenance Lists / Maintenance Intervals .....	40 - 43
Service Kits .....	44
Check V-Belt Tension / Tension V-Belt .....	45
Compressor Lubrication / Check Oil Level .....	46
Oil Change .....	47
Oil Sieve Change .....	48
Final Pressure Switch .....	49



## TABLE OF CONTENTS

---

### **Maintenance &Service**

Automatic Condensation Dump System .....	50
Oil / Water Separators 1st, 2nd & 3rd Stage - Maintenance .....	51 - 52
Condensate Stop Valve- Maintenance .....	53
Pneumatic Condensate Valve - Maintenance .....	54
Filter Housing / Filter Cartridge .....	55
Filter Cartridge Replacement.....	56
Filter Housing - Maintenance.....	57
0.8 Itr Filter Element Change .....	58
0.8 Itr Pre-Filter Housing - Maintenance .....	59
Inlet Filters / Inlet Filter Cartridge Change .....	60
Cylinder Heads and Valves .....	61
Replace In- / Outlet Valves 1st & 2nd Stage .....	62 - 63
Replace In- / Outlet Valves 3rd & 4th Stage .....	64
Replace Piston Rings and Needle Bearings of the 2nd, 3rd & 4th Stage.....	65 - 66
Safety Valves .....	67
Pressure Maintaining / Non Return Valve .....	68
Safety Valve Test .....	69
Leak Test .....	70
Pressure Vessel Test .....	71
Maintenance Records .....	72 - 77

### **Storage**

Conservation / Storage of Compressor Unit .....	78
De-conservation, Re-commissioning .....	78
Transportation Instructions / Disposal .....	79

A

## GENERAL INFORMATION

---

### General Information

We strongly recommend to read this manual thoroughly prior to operation and to follow all the safety precautions precisely. Damage resulting from any deviation from these instructions is excluded from warranty and liability for this product. Carry out other commissioning steps only if you have fully understood the following contents.

Before commissioning and using the unit, carry out all the essential preliminary work and measures concerning legal regulations and safety.

These are described on the following pages of this operation manual.

A

### Description of Marks & Warning Signs

The following warning signs are used in this document to identify the corresponding warning notes which require particular attention by the user. The warning signs are defined as follows:



#### Caution

Indicates an imminently hazardous situation which, if not avoided, could result in serious injury, physical injury or death.



#### Warning

Indicates a potentially hazardous situation which, if not avoided, could result in physical injury or damage to the product or environment.



#### Note

Indicates additional information on how to use the unit.



## DESCRIPTION

---

### Scope of Delivery

Compressors are provided in different equipped versions.

### Versions

#### Filling pressure versions:

- PN 225 bar
- PN 330 bar
- PN 225 / 330 bar

### Specifications

- Electro motor (400V / 3 Phase / 50 Hz)
- Painted steel housing (RAL 6026)
- Sound insulated housing
- Automatic condensate drain
- Automatic stop at final pressure
- Hour counter
- Operation panel with start/stop and condensate test button, emergency stop switch
- Motor protection switch
- Safety door switches
- Pressure maintaining- / non return valve
- Pistons with steel piston rings
- Improved lubrication system c/w oil filter
- Low pressure oil pump c/w oil sieve
- Oil- / water separators after each stage
- Safety valves after each stage
- 0.8 ltr. pre filter
- Condensate-stop-valves
- 10 ltr. condensate tank with venting silencer
- Three service covers
- 4 concentric suction/pressure valves
- High pressure outlet, size: 10L
- Breathing air purification an accordance to EN 12021

### Options

- Auto start system
- Up to 6 additional hoses available
- 4- fold filling panel installed at front door
- 200 and 300 bar parallel filling pressures
- Oil pressure gauge
- Intermediate pressure gauges
- Oil pressure monitoring c/w auto shut down
- Cylinder head temperature monitoring with auto shut down
- Oil temperature display with auto shut down
- Puracon filter monitoring (auto shut down also available)
- ECC Control
- Phase monitoring c/w shut down at wrong direction of rotation
- Block heating device
- 420 bar Version
- Power cable and plug
- Special voltages / frequencies on request
- Air cooler connecting kit
- Filling connectors to your choice (DIN 200 or 300 bar, CGA 200 or 300 bar, INT)

## DESCRIPTION

### Technical Data



A

Technical Data	LW 700 ES II
Flow Rate [l/min]:	700
Max. Operating Pressure [bar]:	420
RPM [min <sup>-1</sup> ]:	1,390
Number of Pressure Stages:	4
Cylinder Bore 1st Stage [mm]:	Ø 105
Cylinder Bore 2nd Stage [mm]:	Ø 50
Cylinder Bore 3rd Stage [mm]:	Ø 25
Cylinder Bore 4th Stage [mm]:	Ø 14
Medium:	Compressed Air / Breathing Air
Intake Pressure:	atmospheric
Oil Pressure (at operating temperature) [bar]:	+2.0 (±0.1)
Oil Capacity [l]:	2.9
Intake Temperature [°C]:	0 < +45
Ambient Temperature [°C]:	+5 < +45
Cooling Air Volume [m <sup>3</sup> /h]:	> 5,550
Voltage:	400 V / 3 phase / 50 Hz
Protection Class Drive Motor:	IP 55
Drive Power [kW]:	18.5
RPM Motor [min <sup>-1</sup> ]:	2,940
Start:	Star/Delta
Noise Level [dB(A)]:	75 (±2) at distance of 1 m
Dimensions W x D x H [mm]:	995 x 1,487 x 1,800
Weight [kg]:	605
Content Volume Final Filter Housing [l]:	2.3
Content Volume Pre-Filter Housing [l]:	0.8



**DESCRIPTION**

**Technical Data - Overview Operating Noise dB(A)**

**A**

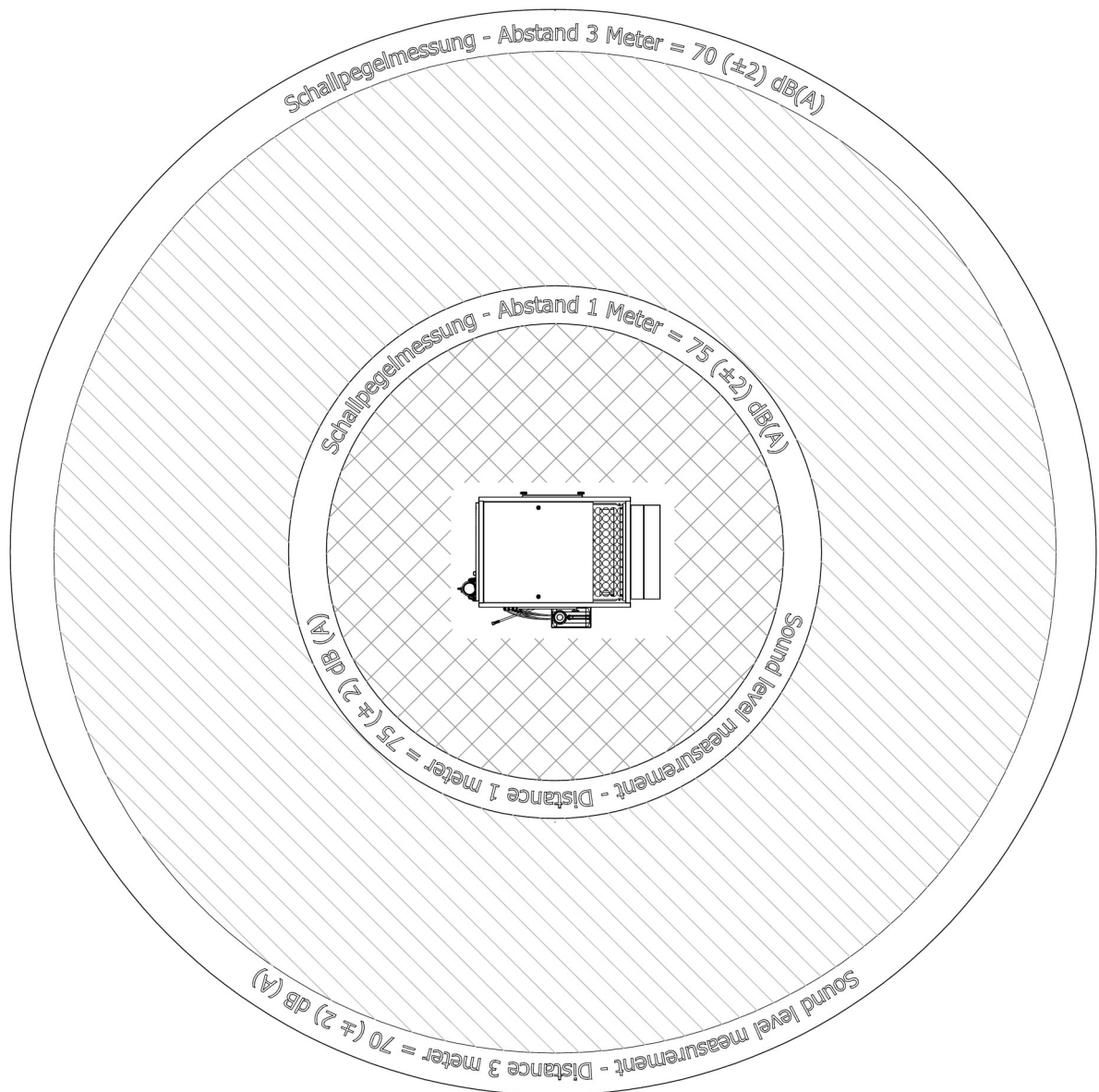

## DESCRIPTION

### Over View LW 700 ES II

A



No.	Designation
1	Filling Pressure Gauge
2	Switchboard
3	Filter Housing
4	Pressure Maintaining / Non Return Valve
5	Pre-Filter, Volume: 0.8 Litre

## DESCRIPTION

### Switchboard

A



No.	Designation
1	Emergency Shut-off Switch
2	Hour Counter
3	ON - Button
4	OFF - Button
5	Drain Test - Button

# DESCRIPTION

## Flow Chart

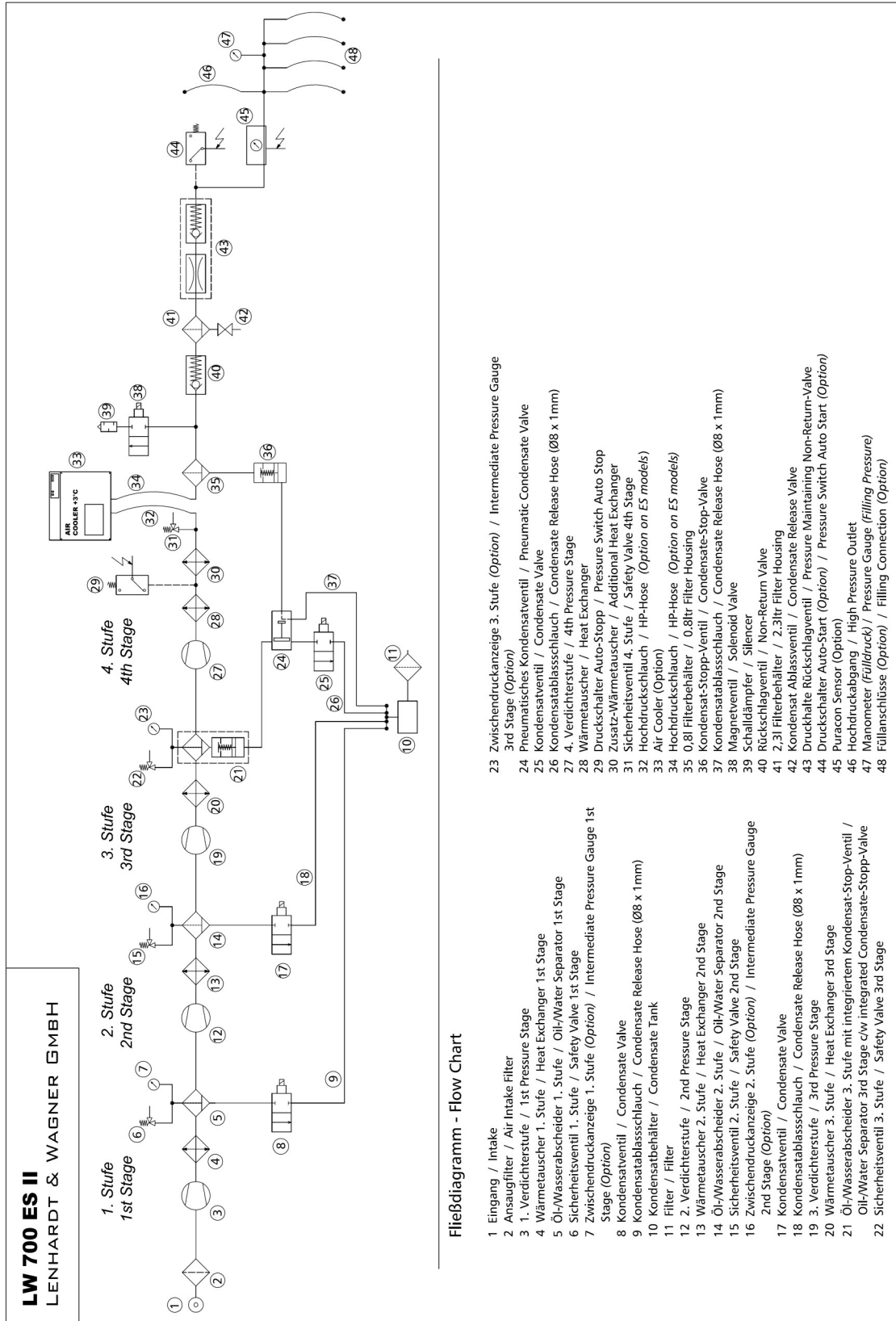

A



A

# SAFETY PRECAUTIONS



## **SAFETY PRECAUTIONS**

---

**A**

### **Intended Use**

Only use the unit in perfect condition for its intended purpose, safety and intended use and in accordance with the operating instructions! In particular disorders that may affect safety have to be eliminated immediately!

Use the unit exclusively for the determined medium (see "Technical Data"). Any other use that is not specified is not authorized. The manufacturer/supplier shall not be liable for any damages resulting from such use. Such risk lies entirely with the user. Authorization for use is also under the condition that the instruction manual is complied with and inspection and maintenance requirements are enforced.

No change and modification to the unit can be made without the written agreement of the manufacturer. The manufacturer is not liable for damage to persons or property resulting from unauthorized modifications.

### **Operators**

Target groups in these instructions;

#### **Operators**

Operators are persons who are authorized and briefed for using the compressor.

#### **Qualified personnel**

Qualified personnel are persons who are entitled to repair, service, modify and maintain the system.



#### **Warning**

Only trained personnel are permitted to work on the unit!



#### **Warning**

Work on the electrical equipment on / with the machine / unit may only be carried out by qualified electricians.

## **SAFETY PRECAUTIONS**

---

### **Safety Instructions on the Unit**

Importance of notes and warning signs that are affixed to the compressor according to the application or its equipment.

**A**



**Warning**  
High Voltage!



**Note**  
Ensure correct direction of rotation!



## **SAFETY PRECAUTIONS**

---

### **General Safety Precautions**

- Read the Operating Instructions of this product carefully prior to use.
- Strictly follow the instructions. The user must fully understand and strictly observe the instructions. Use the product only for the purposes specified in the intended use section of this document.
- Do not dispose the operating instructions. Ensure that they are retained and appropriately used by the product user.
- Only trained and competent personnel are permitted to use this product.
- Comply with all local and national rules and regulations associated with this product.
- Only trained and competent personnel are permitted to inspect, repair and service the product.
- Only authentic L&W parts and accessories may be used for maintenance work. Otherwise, the proper functioning of the product may be impaired.
- Do not use faulty or incomplete products. Do not modify the product.
- Inform L&W in the event of any product or component fault or failure.
- The quality of the air supply must meet EN12021 specifications for breathing air.
- Do not use the product in areas prone to explosion or in the presence of flammable gases. The product is not designed for these applications. An explosion might be the result if certain conditions apply.

**A**





## **SAFETY PRECAUTIONS**

---

### **Unit Customised Safety Notices**

#### **Organisational Measures**

- In addition to the instruction manual, observe and comply with universally valid legal and other obligatory regulations regarding accident prevention and environment protection.
- In addition to the instruction manual, provide supplementary instructions for supervision and monitoring duties taking into consideration exceptional factors e.g. with regard to organisation of work, production, personnel employed.
- Supervise personnel's work in accordance with the instruction manual, taking into account safety and danger factors.
- Observe all safety and danger notices on the compressor and check readability and completeness.

#### **Safety Instructions Operation**

- Take measures to ensure that the machine is only taken into operation under safe and functional conditions. Only operate the compressor if all protective and safety equipment, e.g. detachable protective equipment, are provided and in good working order.
- Check the compressor at least once per day for obvious damage and defects. Inform the responsible department / person immediately if anything is not as it should be (including operation performance). Shut down the machine immediately if necessary and lock it.
- In case of malfunction, stop the compressor immediately and lock it. Repair malfunctions immediately.
- If there is a failure in the electric energy supply, shut down the machine / unit immediately.
- Ensure safe and environmentally friendly disposal of consumables and old parts.
- The stipulated hearing protectors must be worn.
- Soundproofing equipment on the compressor has to be activated in safety function during operation.
- When handling with fats, oils and other chemical agents, observe the note for the product-related safety.



## SAFETY PRECAUTIONS

---

### Maintenance Instructions

- Hoses have to be checked by the operator (pressure and visual inspection) at predetermined intervals, even if no safety-related defects have been detected.
- Immediately repair any damage. Escaping compressed air can cause injury.
- Depressurise system and pressure lines before beginning repair work.
- Adjustment, maintenance and inspection activities and keep appointments, including information on replacement parts / equipment, prescribed in the operating instructions have to be respected.
- If the machine / equipment is completely off during maintenance and repair work, it must be protected against unexpected restart. Turn off main control device and remove the key and/or display a warning sign on the main switch.
- The machine and especially the connections and fittings should be cleaned from oil, fuel and maintenance products at the beginning of the maintenance / repair. Do not use aggressive cleaning agents. Use fibre-free cleaning cloths.
- Only clean the compressor with a slightly damp cloth. Remove dirt from cooling pipes by using a brush.
- After cleaning, examine all pipes for leaks, loose connections, chafing and damage. Immediately eliminate any faults.
- Always retighten any pipe connector loosened for maintenance or repair work.
- If it is necessary to remove safety devices for maintenance and/or repair work, these must be replaced and checked immediately after completion of the maintenance and/or repair work.
- The electrical equipment of the compressor must be regularly checked. Defects, such as loose screw connections or burnt wires, must be immediately rectified by electrically skilled personnel.
- Only personnel with particular knowledge and experience with pneumatics may carry out work on pneumatic equipment.
- Only personnel with particular knowledge and experience in gas equipment may carry out work on gas equipment.

A



## **SAFETY PRECAUTIONS**

---

### **Transportation Instructions**

- Parts which need to be dismantled for transport purposes must be carefully replaced and secured before taking into operation.
- The transport may only be carried out by trained personnel.
- For transportation, only use lifting devices and equipment with sufficient lifting power.
- Do not stand or work under suspended loads.
- Also separate from minor relocation machinery / system of any external energy supply. Before recommissioning, reconnect the machine to the mains according to regulations.
- When recommissioning, proceed according to the operating instructions..

### **Safety Regulations**

- Inspections according to legal and local obligatory regulations regarding accident prevention are carried out by the manufacturer or by authorised expert personnel. No guarantees whatsoever are valid for damage caused or favoured by the non-consideration of these directions for use.

**A**



A

# INSTALLATION

## INSTALLATION

### Installation in Closed Rooms



#### Danger

No operation in explosion-hazard areas.

The unit is not approved for operation in areas prone to explosion.

#### For installation in closed rooms, observe the following:

- Install the unit horizontally and level. The floor must be vibration-free and capable of taking the load of the system weight.
- The compressor room should be clean, dry, dust free and as cool as possible, but should not exceed the minimum temperature of +5°C. Avoid direct exposure to sunlight. If possible, install unit in such a manner that the compressor fan can intake fresh air from outside. Ensure adequate ventilation and exhaust air opening.
- When locating the compressor in rooms of less than 30 m<sup>3</sup> space, where natural ventilation is not ensured or other systems having high radiation are operating in the same room, measures must be taken to provide artificial ventilation.
- Intake air must be free of noxious gas e.g. smoke, solvent vapours, exhaust fumes etc.
- Observe the specified operating temperature (see "Technical Data")!



#### Note

The intake air must be free of harmful gases.

We recommend to use an intake hose in order to get fresh air from the outside.

#### Benchmarks - Diameter of the suction hose as a function of the suction hose length

Pos.	Length of suction hose [m]	Diameter suction hose [mm]
1	≤ 3	Ø 30
2	≤ 10	Ø 80
3	≤ 15	Ø 100
4	≤ 20	Ø 120

# INSTALLATION

## Dimensions

A

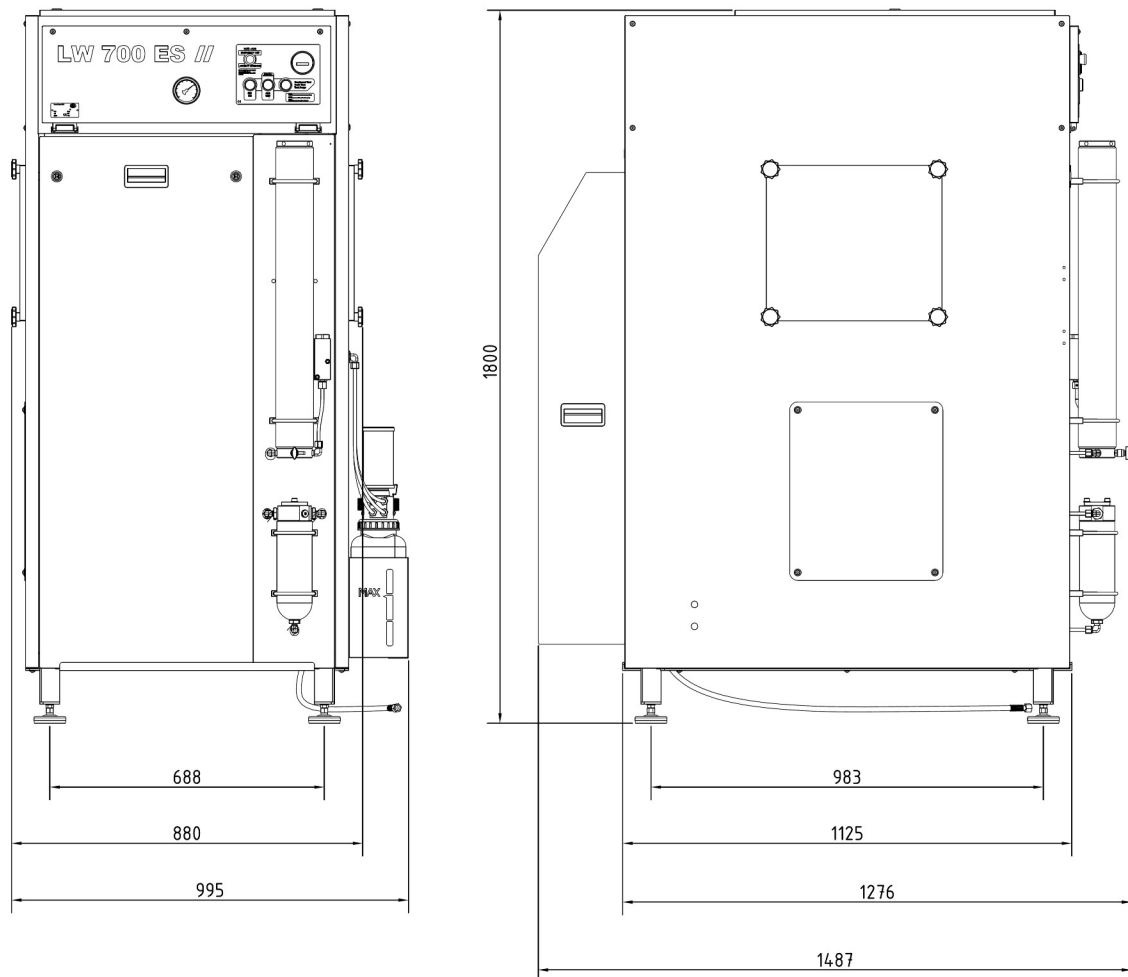

Fig. Dimensions

## INSTALLATION

### Minimum Distances



#### Note

Minimum distances must be adhered!

- The following minimum distances must be adhered:  
Front side: > 1500 mm  
Sides and rear side: > 500 mm  
Distance to ceiling: > 500 mm  
Avoid anything in these areas which would restrict cooling air flow.

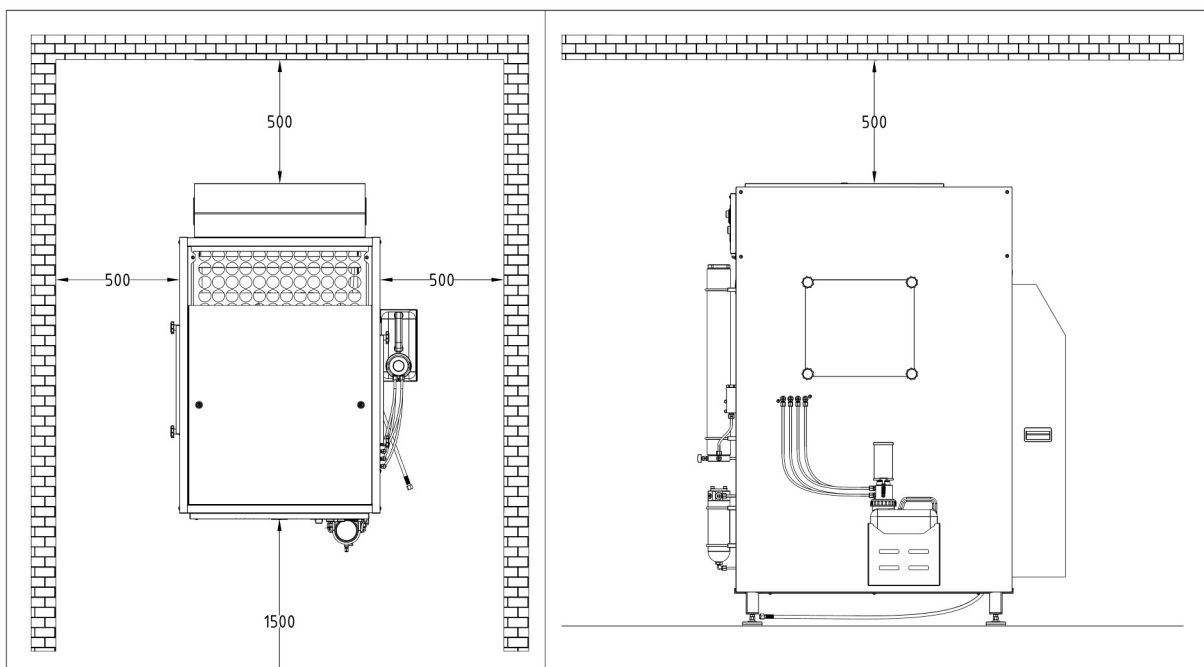

Fig. Minimum distances

## INSTALLATION

### Ventilation

- Make sure that the compressor always has sufficient amount of fresh air available for cooling.
- To prevent serious damage, ensure that the cooling air flow can flow freely.
- The necessary cooling air flow can be calculated by using the following formula:  
 $300 \times \text{drive power [kW]} = \text{required cooling air flow [m}^3/\text{h]}$   
 Example 18.5 kW motor:  $300 \times 18.5 \text{ kW} = 5550 \text{ m}^3/\text{h} = \text{required cooling air flow.}$
- Fan capacity for cooling air in- & outlet must be sufficient.  
 Always make sure that ambient temperatures are within the stated limits ( $+5^\circ\text{C} < +45^\circ\text{C}$ ).

A

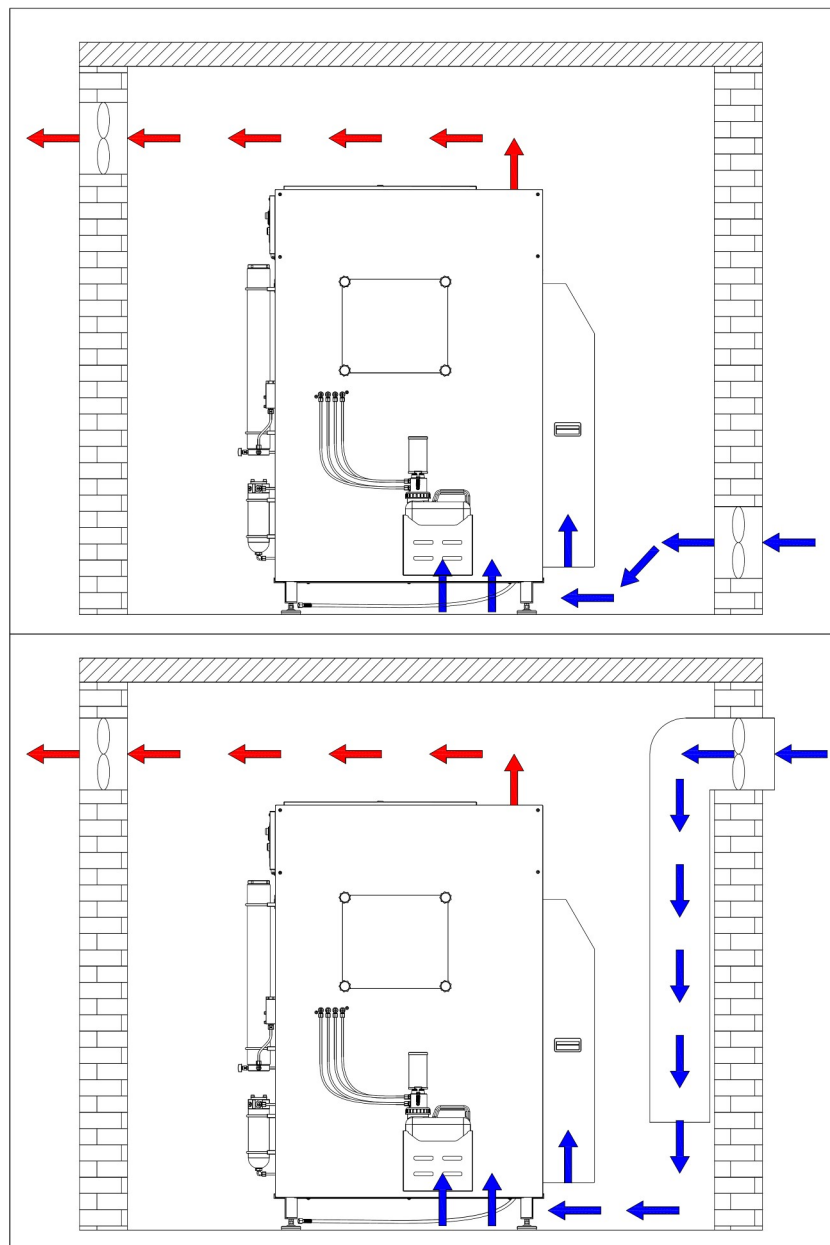

Fig. Ventilation through facade & Ventilation via ventilation stack



## INSTALLATION

### Electrical Installation



#### Warning

Work on the electrical equipment on / with the machine / unit may only be carried out by qualified electricians.

For installation of electrical equipment, observe the following:

- If control devices are delivered by the factory, refer to the appropriate wiring diagram.
- Ensure correct installation of protective conductors.
- Check conformity of motor and control device voltage and frequency with those of the electric network (see name plate on the compressor).
- The fusing should be done in accordance with the valid regulations of the responsible electricity supply company.
- When connecting the unit to the electrical supply, check the compressor direction of rotation (see chapter "Maintenance" -> Check turning direction).
- Fuse the motor correctly (see table; use slow-blow fuses).

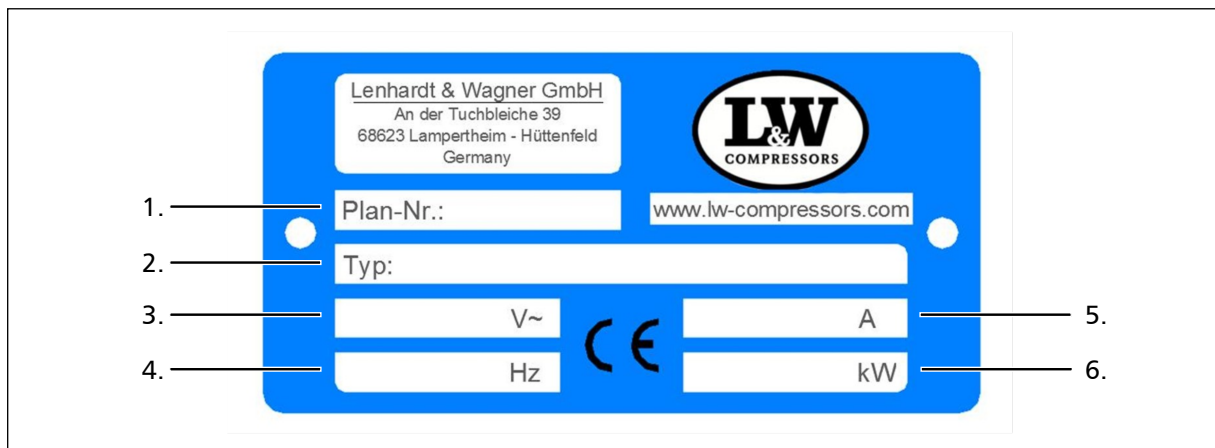

Fig. Compressor name plate

No.	Designation
1.	Circuit diagram number
2.	Compressor type
3.	Power supply
4.	Frequency
5.	Motor current consumption
6.	Nominal motor power

## INSTALLATION

### Electrical Installation

The standard compressor version is prepared for the connection to three phases (brown, black, grey), neutral conductor (blue) and protective earth conductor (green/yellow).

Fig. - Connection to the switch box

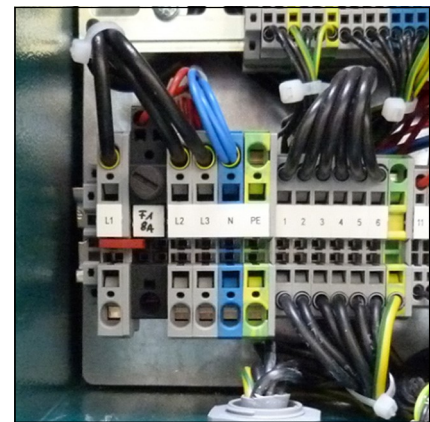

A

### Recommended fuses for 360 - 500 V operating voltage

Nominal motor power		Fusing start current A		Connection in mm <sup>2</sup>	
[kW]	[A]	Direct	Star/Delta	Contactor supply	Motor S/D
2.2	5	10	-	1.5	1.5
4	8.5	20	-	2.5	1.5
5.5	11.3	25	20	2.5	1.5
7.5	15.2	30	25	2.5	1.5
11	21.7	-	35	4	2.5
15	29.9	-	35	6	4
18.5	36	-	50	6	4
22	41	-	50	10	4
30	55	-	63	10	6

### Recommended fuses for 220 - 240 V operating voltage

Nominal motor power		Fusing start current [A]		Connection in mm <sup>2</sup>	
[kW]	[A]	Direct	Star/Delta	Contactor supply	Motor S/D
2.2	8.7	20	-	1.5	1.5
4	14.8	25	-	2.5	1.5
5.5	19.6	35	25	4	2.5
7.5	26.4	50	35	6	4
11	38	-	50	6	4
15	51	-	63	10	4
18.5	63	-	80	16	6
22	71	-	80	16	6
30	96	-	125	25	10



A

# OPERATION



## OPERATION

---

### Important Operation Instructions



#### Note

Ensure that all persons handling the compressor are familiar with function and operation of the unit.



#### Wear hearing protection

When working on a running machine, always wear hearing protection.

A

## FIRST COMMISSIONING

---

A

### Prior to first commissioning, observe the following:

Necessary steps are described on the next pages.

- Ensure that cooling air flow is not restricted.
- Check compressor oil level by the oil indicator glass (see page 27).
- Check all connections and retighten if necessary.
- Check if filter cartridge is in place (see "Service and Maintenance").
- Check V-belt tension.
- Connect HP-hose to pipework, storage or filling panel.
- Check if all filling / storage valves are closed.
- Grip filling connector and open filling valve
- Start the compressor by pushing the ON button (ECC Version: key 1).
- Check direction of rotation - see arrow marking near impeller (see page 28).  
If the direction of rotation is wrong, immediately stop the compressor by pushing the OFF button and contact an authorised electrician.
- Check oil pressure (if oil pressure gauge is fitted).
- Run compressor unit for about 2 minutes.
- Carefully close the open filling valve.
- Run the compressor up to maximum pressure and check if final pressure switch shuts off the machine. If the final pressure switch does not shut off, switch off the compressor by pressing the OFF button (see chapter "REMEDYING FAULTS").
- Check the compressor unit for any kind of leaks (see "SERVICE AND MAINTENANCE")
- Check the condensate drain valves:
  - Position and fix condensate hoses (use suitable container).
  - Press the blue "Condensate Test" button .
  - Check if air escapes through every single drain hose.
- Stop the compressor by pushing the OFF button (ECC Version: key 0).

#### Warning



Motor is turning the wrong direction!

Immediately after switching on the compressor, check the direction of rotation.

Depending on the location, the phase sequence of the power line could change the direction.

## FIRST COMMISSIONING

---

### Check Oil Level



#### Warning

Check oil level daily. Never start the compressor with low oil level.  
Lack of lubrication can cause major damage.

Check oil before each operation of the system!

The oil level should be between the middle position and the upper end of the oil indicator glass.

Never start the compressor with low oil level.

Refill new compressor oil at least when the oil level has reached the middle position of the indicator.

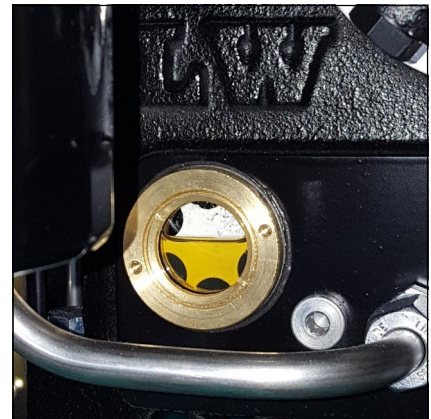

Oil level indicator

### Check V-Belt Tension

The V-belts could lose tension during transportation.

Check the V-belt tension before starting the compressor.

### Tension V-Belt / Correct V-Belt Tension

See chapter "Service and Maintenance" -> "Tension V-belts"

## FIRST COMMISSIONING

---

### Check Rotation Direction



**Warning!**

Immediately after switching on the compressor, check direction of rotation.

Before starting the compressor for the first time, check the direction of rotation - see arrow marking near impeller.

If the direction of rotation is wrong, the gear type oil pump would not supply any oil to the guide cylinders and so the guide pistons lack lubrication, which could lead to serious piston / cylinder damage.

Furthermore, cooling air flow will not be sufficient:

- Danger of overheating!



Arrow Marking

A



## DAILY COMMISSIONING

---

### **Prior to daily operation observe the following:**

- Ensure cooling air can flow freely.
- Check compressor oil level by the oil sight glass.
- Check if filter cartridge is in place / observe filter cartridge life!
- Ensure toxic-free, pure intake air.

A



## OPERATION

---

### Filling Procedure



**Caution! Only fill cylinders which:**

- are marked with the test mark and the test stamp of the expert
- have been hydro tested (check last test date)
- are rated for at least the intended filling pressure
- are free of moisture, dust and dirt



**Note**

- The unit shuts down when final pressure is reached.
- Semi Automatic Mode: needs to be restarted manually
  - Automatic Mode: re-starts if restart pressure is reached

1. Close all filling valves.
2. Connect the compressed air cylinders.
3. Open cylinder valves.
4. Start compressor by pressing the ON button.
5. If the filling pressure increases, slowly open the filling valves.
6. Fill compressed air cylinders to the desired pressure, subsequently close the filling valves slowly.
7. Close all filling valves.
8. Vent filling connectors (L&W lever valves are self venting types)
9. Disconnect compressed air cylinders from filling valves.

## OPERATION

---

### Switch off compressor Unit

As standard the compressor unit is equipped with a pressure switch which automatically shuts down the system when set pressure is reached.

During filling process, you can turn-off the system at any time by pushing the red button (OFF) or pressing the emergency stop (only in case of emergency!).



#### Note

After switching off, all intermediate oil / water separators plus the final 0,8 ltr. filter housing will be vented automatically .



A

# REMEDYING FAULTS

## REMEDYING FAULTS

### Compressor does not reach final pressure

Cause of fault	Remedy
Connections leaking	Retighten or clean/replace if necessary
Final pressure safety valve leaking	Replace
Pipes / heat exchanger damaged	Replace
Condensate drain valves leaking	Unscrew valves, check sealing surfaces, clean, replace if necessary
Final pressure switch stop unit	Verify settings, replace if necessary
Piston of pneumatic condensate valve seized	Clean pneumatic condensate valve and restore function, check/replace o-rings, replace valve completely if necessary

### Strong Compressor Vibration

Cause of fault	Remedy
V-belt tension too loose	Tension V-belt
Drive motor / Compressor unit loosely	Retighten mounting screws
Anti vibration mounts used up	Replace
Ground not levelled	Ensure a solid and level ground

### Flow Rate too Low

Cause of fault	Remedy
Inlet and outlet valves contaminated / defective	Clean, replace if necessary
Cylinder(s), piston(s) or piston ring(s) used up	Replace
V-belt slips	Tension V-belt
See chapter "Final pressure can not be reached"	See chapter "Final pressure can not be reached"

## REMEDYING FAULTS

### Compressor Overheated

Cause of fault	Remedy
Inlet filter cartridge contaminated	Replace
Ambient temperature too high	Improve room ventilation /
Cooling air inlet and outlet insufficient	Observe minimum distances (see Installation Instructions)
Air intake hose too long	Reduce length of the air intake hose
Air intake hose diameter too small	Use a larger diameter
Wrong compressor rotation direction	Ensure correct phase rotation,
Inlet and outlet valves contaminated / defective	Clean, replace if necessary

### Safety Valve Leaks

Cause of fault	Remedy
Inlet and outlet valves of the following pressure stage defective	Clean, replace if necessary
Sinter filter of the following water separator blocked	Replace
Safety valve leaky	Replace

### Oil Taste in the Air

Cause of fault	Remedy
Mole carbon filter cartridge saturated	Replace
Compressor oil unsuitable	Use prescribed oil quality
Filter cartridge unsuitable	Use prescribed filter type
Cylinder(s), piston(s) or piston ring(s) defective	Replace

## REMEDYING FAULTS

### Automatic Condensate Drain Defective

Cause of fault	Remedy
Solenoid coils defective	Replace
Cable / supply cable defective	Repair, replace if necessary
Timer / relais defective	Replace
Sinter filter of pneumatic condensate valve blocked	Replace
Piston of pneumatic condensate valve sticks	Clean pneumatic condensate valve and restore function, check/replace o-rings, replace valve complete if necessary

### Condensate Drain Starts before reaching Final Pressure

Cause of fault	Remedy
Pressure stages are not as prescribed, control pressure of pneumatic condensate valve too low	Check corresponding inlet and outlet valve, replace if necessary.
Piston sealing of pneumatic condensate valve contaminated / used up	Clean, replace if necessary
Timer / relais settings not correct	Adjust as prescribed
Timer / relais defective	Replace

### Compressor Stops before Final Pressure

Cause of fault	Remedy
Final pressure switch settings not correct	Correct settings
Opening pressure of the pressure maintaining valve too high	Correct settings
Fuse / circuit breaker has tripped Valid only for E models	Check fusing of the power supply / observe regulations
Emergency stop switch has tripped	Unlock emergency stop switch, close compressor housing door correctly



## REMEDYING FAULTS

### Filter Life not Sufficient

Cause of fault	Remedy
Pressure maintaining valve settings not correct	Adjust as prescribed
Filter cartridge unsuitable	Replace by a prescribed filter cartridge type
Filter cartridge too old	Observe expiration date
Filter cartridge packaging incorrect / damaged / already opened. Filter cartridge already partly saturated before change	Store filter cartridges properly, dispose defective cartridges
Operating temperature too high	Ensure sufficient ventilation
Cylinder(s), piston(s) or piston ring(s) defective	Replace

### Oil Consumption too High

Cause of fault	Remedy
Cylinder(s), piston(s) or piston ring(s) defective	Replace
Compressor oil unsuitable	Use prescribed oil quality
Operating temperature too high	Observe prescribed operating temperatures
Oil leak at the compressor block	Tighten corresponding mounting screws, if necessary replace corresponding paper sealing / o-ring / shaft seal

A



A

# MAINTENANCE AND SERVICE



### Service, Repair and Maintenance

Carry out service and maintenance work exclusively when the compressor is stopped and depressurised. The unit should be leak-checked regularly. Leaks can be preferably localised by using a leak detector spray (if necessary, brush pipes with soapy water).

We recommend that only authorised L&W service technicians carry out service work on the bearing of the compressor (crankshaft and connecting rods).

We urgently recommend that all maintenance, repair and installation work must only be carried out by trained personnel. This is necessary because all maintenance work can not be explained exactly and detailed in this manual.

Only use authentic L&W spare parts for service work.

**Danger**

Components under pressure, such as hose ends, can quickly come loose when manipulated and can cause potentially fatal injuries due to the pressure surge. Any work on system parts may only be performed in a pressure-compensated state.

**Warning**

The use of accessories that have not been tested can lead to death or serious injury or damage to the unit. Only use authentic L&W spare parts for service work.

**Warning**

Carry out maintenance or service work when the unit is switched off and protected against unexpected restart.

**Warning**

Risk of burns!

Carry out maintenance or service work when the unit has cooled down.



## MAINTENANCE AND SERVICE

### Daily before taking it into Operation

Maintenance work	Type	Quantity	Order No.
Check oil level	-	-	000001
Check condition of all high pressure hoses	-	-	-
Check filter cartridge lifetime	-	-	-
Operate unit to final pressure and check function of final pressure switch	-	-	-

### At 25 Operation Hours

Maintenance work	Type	Quantity	Order No.
Oil change	-	2,9	000001
Replace Oil Filter Cartridge	-	1	009446

### Every 3 Months or as Required

Maintenance work	Type	Quantity	Order No.
Check/Retorque all connections and bolts Drain final filter housing in regular intervals, in dependance to the amount of liquids	-	-	-
Open solenoid valve at the 2.3ltr filter housing, drain condensate if necessary	-	-	-



## MAINTENANCE AND SERVICE

### Annually

Maintenance work	Type	Quantity	Order No.
Oil change, if less than 1000 operating hours	-	2.9	000001
Replace Oil Filter Cartridge	-	1	009446
Check V-belt tension and condition	LW 700 ES II (50Hz)	2	001413
	LW 700 ES II (60Hz)	2	010742
Check opening pressure of final safety valve	-	-	-
Clean coolers	-	-	-
Clean all oil/water separators, if less than 500 operating hours	-	-	-
Service intake filter (depends on condition - if less than 500 operating hours)	-	-	-
Check all connections for leakage	-	-	-

### Every 500 Operating Hours

Maintenance work	Type	Quantity	Order No.
Change intake filter	-	1	000170
Check pressure maintaining/non-return valve	-	-	-
Check V-belt tension and condition	LW 700 ES II (50Hz)	2	001413
	LW 700 ES II (60Hz)	2	010742



#### Note

All stated quantities are parts of our 1000h, 2000h and 4000h service kits. You can find an overview on page Service Kits.

A

## MAINTENANCE AND SERVICE

### Every 1000 Operating Hours

Maintenance work	Type	Quantity	Order No.
Replace sintered metal filter element of water separators	1 / 2 / 3 Stage	3	000173
Replace o-rings of water separators	1 / 2 / 3 Stage	9	001272
Replace sintered metal filter of water separators and condensate-stop-valve version 1	-	2	000188
Replace sintered metal filter of pneumatic condensate valve and condensate-stop-valve v2	-	4	002914
Replace oil sieve	-	1	009545
Replace oil pump cover gasket	-	1	009546
Replace Oil Filter Cartridge	-	1	009446
Oil change	-	2,9	000001
Replace o-rings of the final filter housing	-	2	001287
Replace back-up rings of the final filter housing	-	2	001285
Replace o-ring of the 0.8 ltr. Prefilter	-	1	004221
Replace back-up rings of the 0.8 ltr. Prefilter	-	1	004222
Replace Filter water separator 0.8 Ltr	-	1	003980
Replace o-ring, condensate-stop-valve	-	2	001264
Replace o-ring, condensate-stop-valve housing	-	1	006382
Replace sintered metal filter of solenoid valve 350bar	-	1	003159
Replace Filter Condensate Catch Tank	-	1	006462
Replace o-ring Filter Condensate Catch Tank	-	1	002152
Replace intake filter	-	1	000170



#### Note

All stated quantities are parts of our 1000h, 2000h and 4000h service kits. You can find an overview on page Service Kits.

## MAINTENANCE AND SERVICE

### Every 2000 Operating Hours

Maintenance work	Type	Quantity	Order No.
Replace all inlet and outlet valves incl. gaskets	1st stage	1	000369
	2nd stage	1	000256
	3rd stage	1	010346
	4th stage	1	010347
	Upper gasket 1st	1	000349
	Upper gasket 2nd	1	000254
	Lower gasket 1st	1	000350
	Lower gasket 2nd	1	003492



#### Note

All stated quantities are parts of our 2000h and 4000h service kits. You can find an overview on page Service Kits.

### Every 4000 Operating Hours (Latest in 10 years)

Maintenance work	Type	Quantity	Order No.
Replace shaft seal	-	1	008873
Replace o-ring shaft seal cover	-	1	008877
Replace needle bearings for conrod 2nd, 3rd and 4th stage	-	3	003281
Replace o-ring Cylinder flange	-	3	008874



#### Note

All stated quantities are parts of our 4000h service kits. You can find an overview on page Service Kits.

## MAINTENANCE AND SERVICE

### Service Kits

The service kits contain parts for maintenance according to the factory requirements.

The use of the service kits ensures that all required parts are ordered and replaced and gives assurance that all parts are included in the order. Depending on the model and interval, the service kits include parts such as O-Rings, Sinter Filter, Inlet Filter, Silencers, In-&Outlet Valve, Valve Seals and Compressor oil.



Service Kits

### Service Kits LW 700 ES II

Compressor	Frequency	Operating Hours	Order No.
LW 700 ES II	50 Hz	1000 h	010725
LW 700 ES II	50 Hz	2000 h	010726
LW 700 ES II	50 Hz	4000 h	010727

## MAINTENANCE AND SERVICE

### Tension V-belt

Tension V-belt as follows:

- Press the emergency stop button
- Remove front door and side, lower maintenance cover
- Loosen the clamping screws of the fan sheet metal (additional fan)
- Loosen the hexagon nuts of the engine mounting flange
- Loosen the clamping nuts of the "adjustment screw drive motor"
- Preload V-belt with "V-belt tension nut" until correct spring preload is reached (34mm)
- Bring the motor into the horizontal position with the drive motor adjustment screw
- Tighten the fastening nuts on the motor flange
- Tighten the clamping nuts "adjustment screw drive motor"
- Align fan plate (additional fan) and tighten clamping screws
- Check the free movement of the additional fan

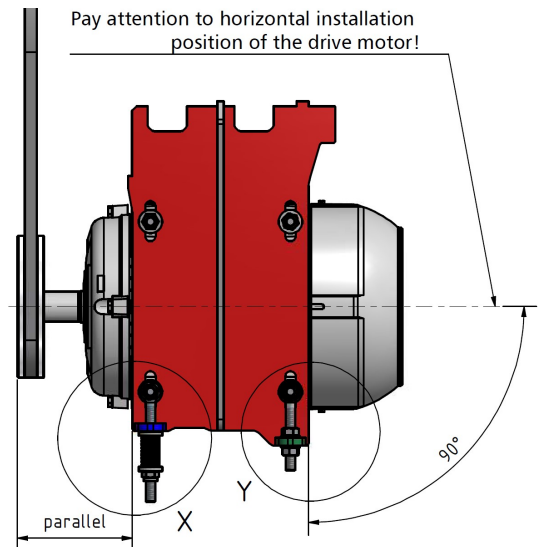
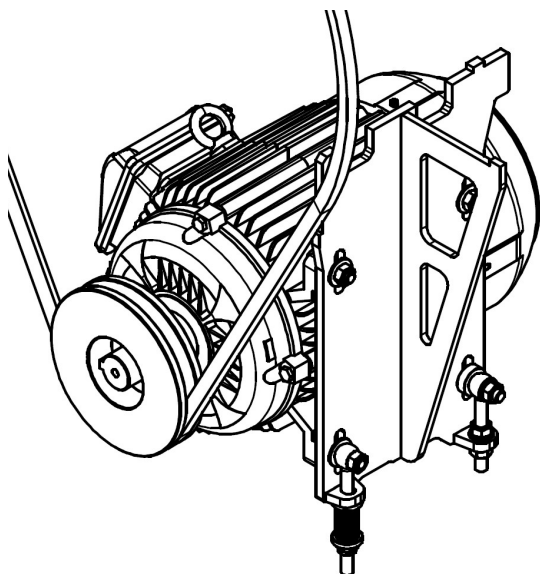

X ( 1 : 2 )

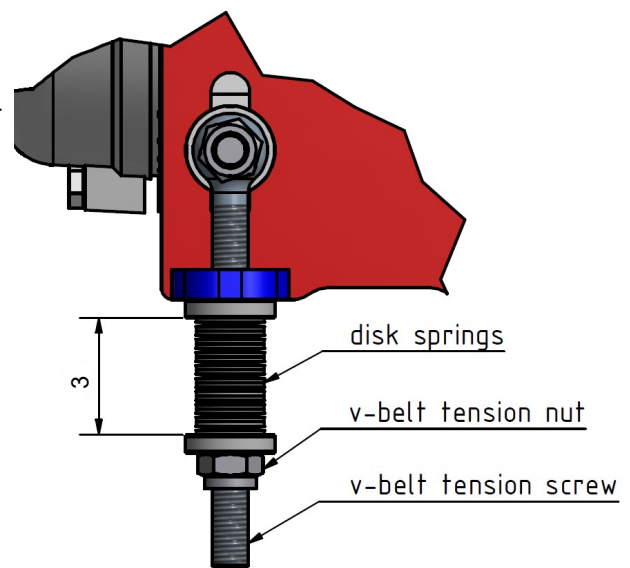

Y ( 1 : 2 )

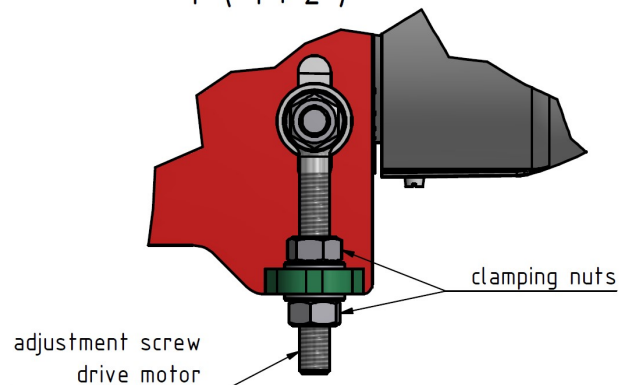

A

## MAINTENANCE AND SERVICE

### Compressor Lubrication

Main bearings (oil pump side), conrod big end bearings and guide cylinders of 3rd and 4th stages are all lubricated by a directly driven, low pressure oil pump (gear type).

Additionally oil spray is used to lubricate the main bearing (flywheel side), plus conrods and cylinders of 1st, 2nd, 3rd and 4th stage.

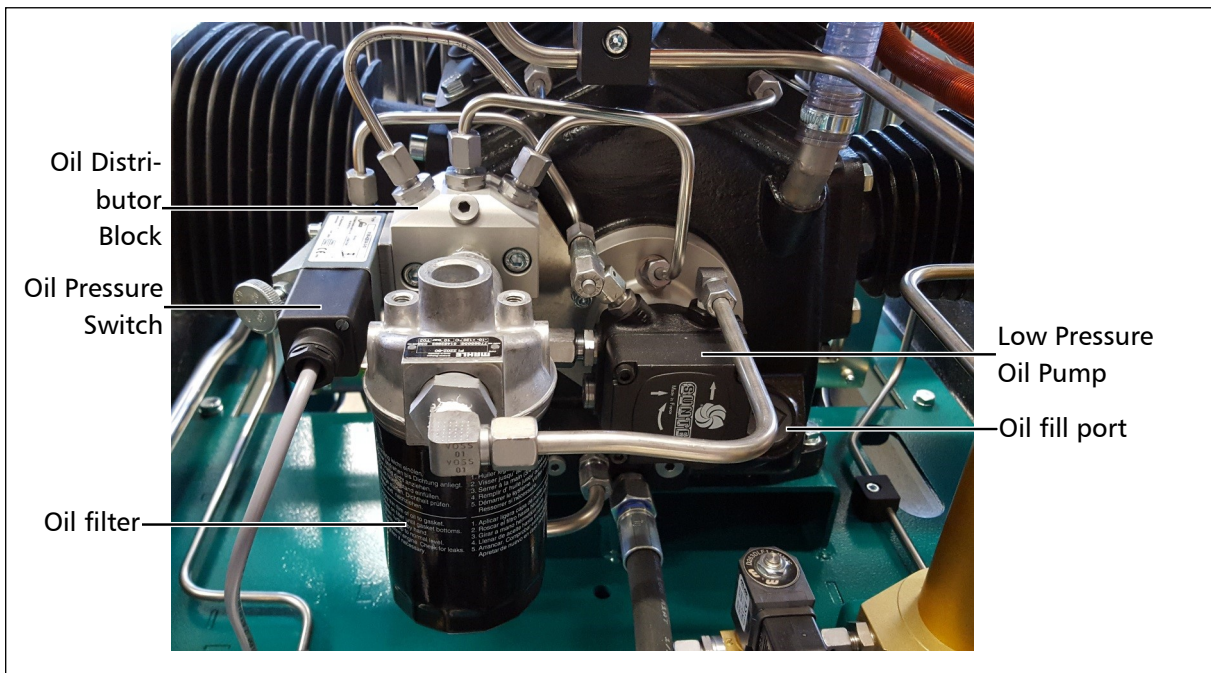

Lubricating System

### Check Oil Level



#### Warning

Check oil level daily. Never start the compressor with a too low oil level. Risk of accidental loss, destruction or deterioration.

Check oil before each operation of the system!

The oil level should be between the middle and upper end of the oil sight glass. Never start the compressor with a too low oil level.

Refill new compressor oil at least when the oil level reached the middle of the indicated area.

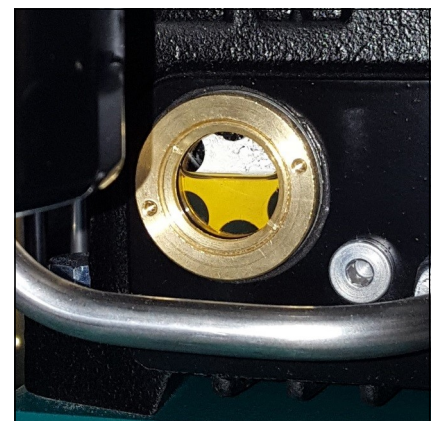

Oil sight glass





## MAINTENANCE AND SERVICE

---

### Oil Change



#### Note

We recommend oil change at least once a year - depending on total operating hours.

A

#### Oil change as follows:

- Run compressor warm for approx. 2 min.
- Switch off and vent compressor. Secure against restarting
- Place a suitable oil drain tray under the drain hose and oil filter.
- Open carefully oil drain valve and drain oil completely.
- Close oil drain valve.
- Change oil filter cartridge with a suitable oil filter key (Part number 009728)  
Pre-fill the new oil filter cartridge with 400 ml synthetic compressor oil
- Loose oil fill port with an appropriate adjustable wrench (AF 0-40 mm) and unscrew manually.
- Fill oil by using a funnel.
- Check oil level. The oil level should be between the middle and upper end of the oil sight glass.
- Screw oil fill port manually in and tighten with the adjustable wrench.

The oil change is now completed.

#### Maintenance Intervals

- First oil- and oil filter change after 25 operating hours (total hours).
- All further changes after each 1,000 operating hours.

#### Oil and Oil Capacity

Approx. 2,900 ml synthetic compressor oil is necessary for one oil change. Only use synthetic compressor oil which is recommended as suitable from L&W.

## MAINTENANCE AND SERVICE

---

### Oil Sieve Change

Oil sieve change as follows:

- Loose cover screws (4 pcs).
- Remove cover, cover gasket and oil sieve.
- Clean oil sieve with petroleum-ether or replace the defective oil sieve.
- Inset oil sieve
- Replace cover gasket.
- Cover gasket with oil before putting it in placing (Take care of the installation direction).
- Remount the cover with the 4 cover screws. Tightening torque: 4.5 - 8 N.

The oil sieve change is now completed.

### Maintenance Intervals

- We recommend cleaning or replacing the oil sieve every 1,000 working hours.
- 009545 - Oil sieve + 009546 - oil pump cover gasket

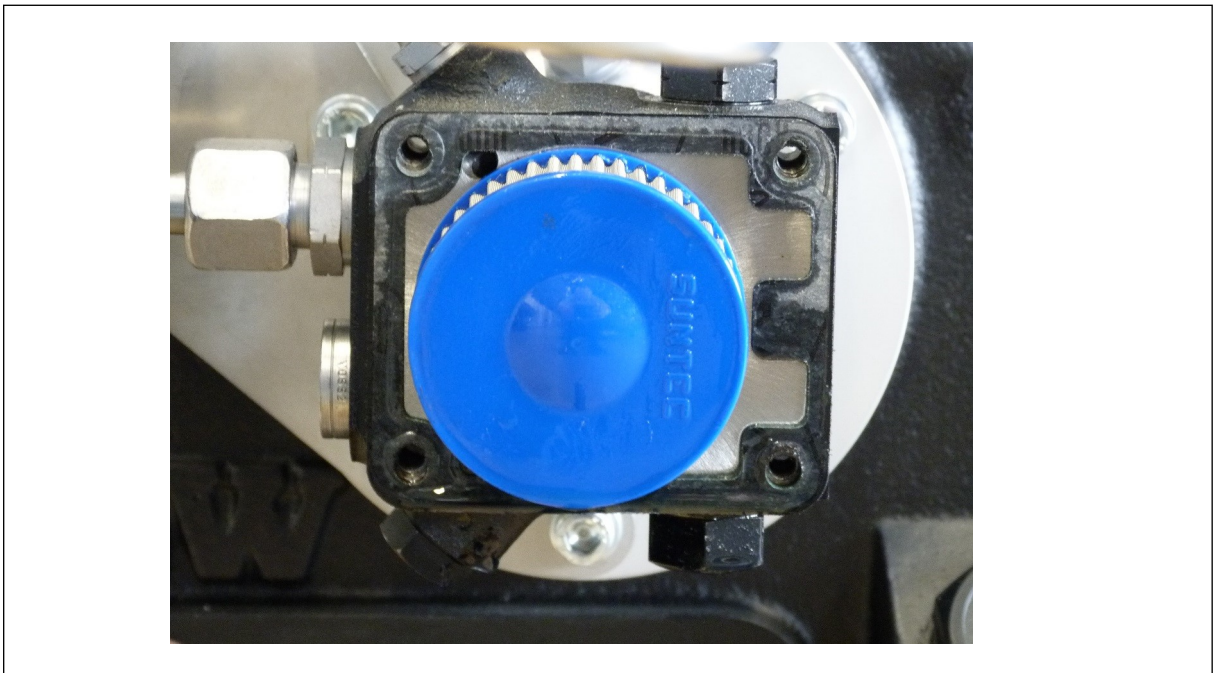

Correct oil sieve mounting direction

### Final Pressure Switch



**Note**

Do not adjust the final pressure switch to the safety valve pressure. The final pressure switch has to be adjusted to min. 10 bar below the safety valve pressure. Otherwise, the safety valve can open during operation. This considerably reduces the life of the safety valve.

The pressure switch shuts off the compressor automatically when the selected final pressure is reached. The final pressure switch is already adjusted to the corresponding cut-out pressure.

The pressure can be adjusted with the upper adjusting screw as follows:

**Increasing cut-out pressure:**

Turn the adjusting screw clockwise

**Reducing cut-out pressure:**

Turn the adjusting screw anti-clockwise

Adjust the pressure switch in steps of a quarter turn. Restart the compressor after every adjustment step to verify the actual cut-out pressure.

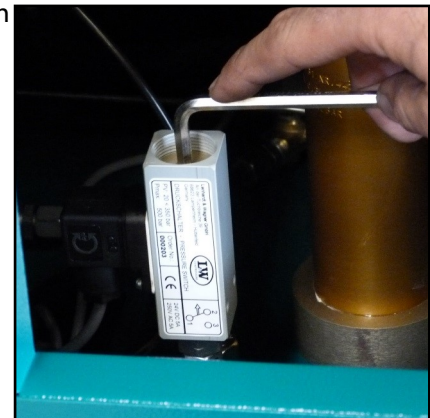

Final pressure switch

**Example Settings:**

Safety valve	Max. Operating Pressure
225 bar	215 bar
250 bar	240 bar
330 bar	320 bar

### Automatic Condensation Dump System



#### Note

The collected condensate can contain oil and has to be disposed according to regulations.

The LW 700 ES II comes as standard with an automatic condensation dump system. Solenoids drain all condensate separators every 15 minutes.

To test the system, press the blue condensate test drain button on the operating panel.

### Oil / Water Separators

Condensate is separated after every stage of compression. All four oil / water separators are equipped with electronic timer controlled solenoids or a condensation valve. The timer is located in the switch box and activates the dump valves about every 15 minutes.

The condensate drains through the black plastic hoses into the 10 liter condensate catch tank.

The drain noise can be kept to a minimum by using a silencer.

### Maintenance Intervals

We recommend to clean oil and water separators every 500 operating hours or at least once a year, to check for corrosion damage and to replace o-rings if necessary.

All oil / water separators have an integrated sinter filter which has to be replaced every 1,000 operating hours.

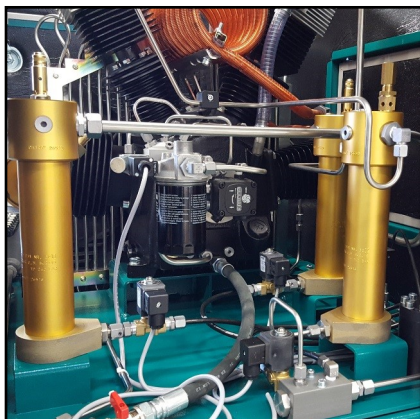

Oil / water separators 1st, 2nd and 3rd stage



Condensate Catch Tank 10 Litre

## MAINTENANCE AND SERVICE

### Oil / Water Separators 1st, 2nd and 3rd Stage - Maintenance



#### Note

Clean all parts thoroughly before assembly.

**Maintenance / cleaning of oil / water separators 2nd stage as follows:**

- Loose pipes and mounting screw
- Remove oil / water separator
- Unscrew and remove filter top (Fig. 1)
- Loose nut of separator top (Fig. 2)
- Change sinter filter (Fig. 3)
- Reassemble all parts and tighten nut
  - *(Only for oil separator 3rd stage)*  
Pull the condensate stop valve out of the filter housing by using threaded rod
  - Change o-ring, previously grease new o-ring (Page 51, Fig. 4).
  - Push the condensate stop valve into the filter housing by using a threaded rod
  - Change o-ring on the top of the filter housing, previously grease new o-ring (Page 51, Fig. 5)
  - Place separator top and tighten
  - Remove the base ring (Page 51, Fig. 6)
  - Change o-rings, previously grease new o-rings (Page 51, Fig. 7)
  - Remove the connection of the base ring and change the sinter filter (Page 51, Fig. 8)
  - Reassemble the connection
  - Mount the base ring
  - Mount oil / water separator
  - Tighten pipes and mounting screw

**The oil / water separator maintenance is now completed.**



Fig. 1 - Unscrew and remove filter top

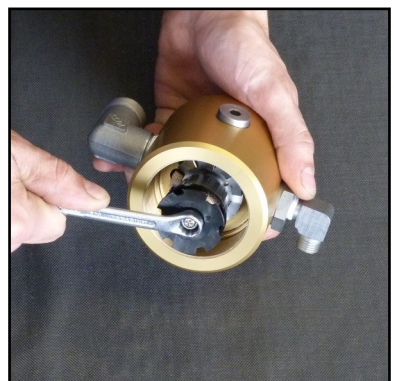

Fig. 2 - Loose nut at the separator top

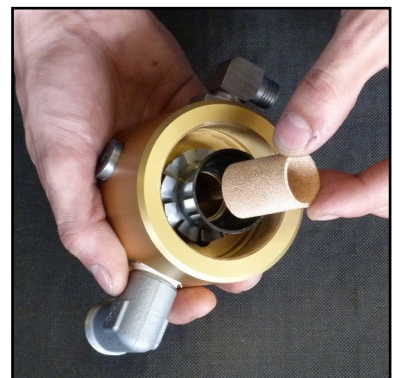

Fig. 3 - Change sinter filter

**Oil / Water Separators 1st, 2nd and 3rd Stage - Maintenance - continued from previous page**

**A**



Abb. 4 - Change o-ring



Abb. 5 - Change o-ring



Abb. 6 - Remove the base ring



Abb. 7 - Change o-rings



Abb. 8 - Change sinter filter

### Condensate Stop Valve - Maintenance



#### Note

Clean all parts thoroughly before assembly.

#### Change/clean condensate stop valve as follows:

- Loose pipes and mounting screws.
- Remove condensate stop valve housing.
- Remove allen bolts and pull off the cover by screwing two allen bolts into the threaded holes (Fig. 2).
- Pull the condensate stop valve out of the filter housing by using a threaded rod
- Change o-ring, previously grease new o-ring (Fig. 3).
- Push the condensate stop valve into the filter housing by using a threaded rod.
- Change o-ring of the cover, previously grease new o-ring (Fig. 4).
- Mount the cover, tighten the allen bolts crosswise.
- Remove the connection on the cover ring and change the sinter filter (*version 1 non threaded version & version 2 threaded version*) (Fig. 5).
- Reassemble the connection
- Mount condensate valve housing.
- Tighten mounting screws and pipes

The oil / water separator maintenance is now completed.

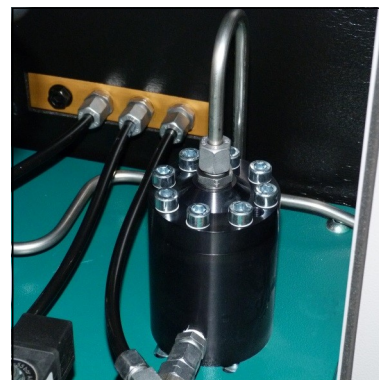

Fig. 1 - Condensate stop valve housing

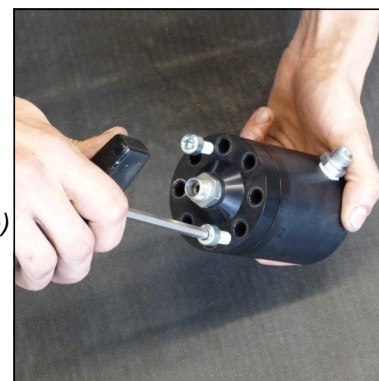

Fig. 2 - Remove the cover



Abb. 3 - O-Ring wechseln  
(Kondensat-Stopp-Ventil)



Abb. 4 - O-Ring wechseln (Deckel  
Kondensat-Stopp-Ventil)

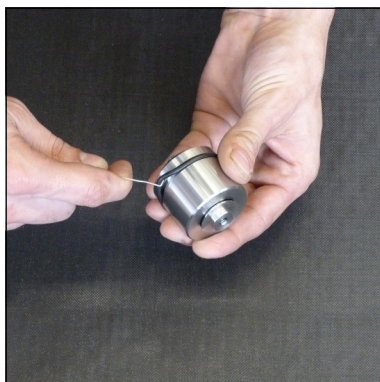

Abb. 5 - Sinterfilter wechseln

## MAINTENANCE AND SERVICE

### Pneumatic Condensate Valve - Maintenance



#### Note

Clean all parts thoroughly before assembly.

#### Pneumatic condensate valve change as follows:

- Loose pipes and mounting screws
- Remove pneumatic condensate valve
- Loose connection (Fig. 2)
- Change sinter filter (Fig. 3)
- Tighten connection
- Mount pneumatic condensate valve
- Tighten pipes and mounting screws

Pneumatic condensate valve maintenance is now completed.

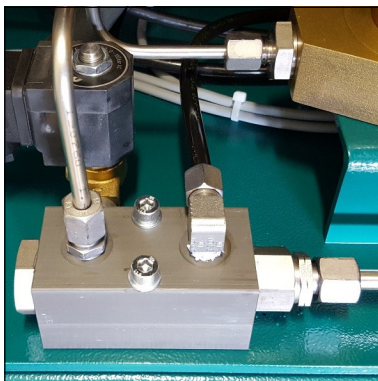

Pneumatic Condensate Valve

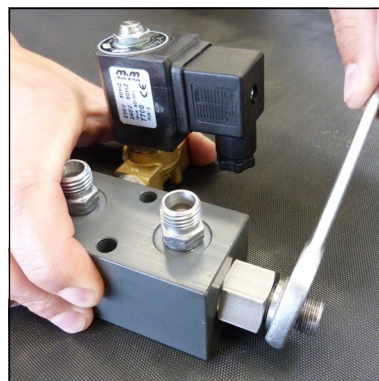

Fig. 2 - Loose connection

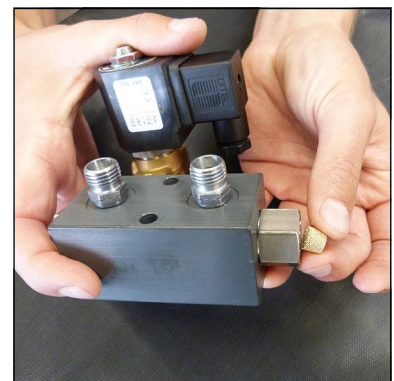

Fig. 3 - Change sinter filter



## MAINTENANCE AND SERVICE

### Filter Housing 2.3 ltr

The mole carbon-filter housing is installed at the right hand side of the front panel.

Inside the filter housing a jet blows air on to the wall of the housing. Condensation water and oil are led by centrifugal force to the bottom of the housing. Air flows through the mole carbon filter cartridge, which purifies the air from residual moisture and odours. The manual condensate drain valve needs to be opened if a drain is necessary and before filter cartridge change.

### Filter Cartridge 2.3 ltr

The high-pressure compressor is equipped with an integrated breathing air purification system. Air is compressed up to 350 bar, dried and odour- and tasteless purified. Oil residues are bounded. The breathing air filter cartridge consists of a molecular sieve and activated-carbon filter.

Cartridge capacity: approx. 2.3 ltr

All breathing air filter cartridges are vacuum sealed.

We recommend unpacking the filter cartridges just before installation. Filter cartridges which are exposed too long could be saturated with moisture and become unusable.

### Maintenance Intervals

The life of the filter cartridge is substantially depend on the operating temperature, from the state of wear of the compressor, of the filter size and the operating pressure.

We recommend to monitor the state of the filter.

### Pre-Filter 0.8 ltr

In particle filter particles are filtererd out up to a size of 10  $\mu\text{m}$ . The pre-filter is separating water before the air enters final filter housing wich is extending the lifetime of the filter cartridge.



Filterhousing 2.3l (upper), pressure maintaining non return valve and filter unit 0,8l with safety valve (below)(down)

A

### Filter Cartridge Replacement

Filter cartridge change as follows:

- Open the condensate valve of the final filter housing until it's depressurized (Fig.1)
- Unscrew filter housing cover by using the special filter tool (Fig.2)
- Place the T-piece end of the filter tool in the recess of the filter cartridge (Fig.3)
- Unscrew the filter cartridge anti-clockwise and pull the cartridge out of the housing (Fig.4)
- Open the packing of the new filter cartridge and place it with the filter tool in the filter housing
- Screw the new filter cartridge hand tight in by using the filter tool
- Screw the cover of the filter housing first manually in
- After it has been completely screwed in, turn cover anticlockwise for 90°. This avoids tightening of the cover due to vibration

The filter cartridge change is now completed.



Fig. 1 - Drain tap



Fig. 2 - Unscrew the filter housing cover.



Fig. 3 - Place the T-piece end of the filter key in the top of the filter cartridge.



Fig. 4 - Pull the cartridge out of the housing.



#### Note

Ensure that the old filter cartridge is disposed correctly at an approved waste point.

### Filter Housing - Maintenance



#### Note

Clean all parts thoroughly before assembly.

#### Filter housing maintenance as follows:

- Open Filter Cover (Fig.1)
- Change o-ring and back-up ring, previously grease both (Fig.2)
- Grease filter cover thread and close

#### Dismount filter housing

- Loose pipes and nuts (Fig.3)
- Remove filter housing
- Dismount filter housing base
- Change o-ring and back-up ring, previously grease both (Fig.4)
- Screw filter base tight in

#### Mount filter housing

- Connect pipe connections and tighten
- Adjust holding clamp and tighten nuts.

The filter housing maintenance is now completed.



Fig. 1 - Open Filter cover



Fig. 2 - Change o-ring and back-up rings



Fig. 3 - Loose pipe connections and nuts



Fig. 4 - Change o-ring and back-up rings

## MAINTENANCE AND SERVICE

### 0.8 ltr Filter Element Change

Filter element change as follows:

- Vent 0.8 ltr filter housing.
- Loosen pipes and nuts (Fig. 1 a. 2)
- Remove complete pre-filter housing.
- Open pre-filter cover (Fig. 3).
- Change the filter element (stuck in filter cover) (Fig. 4).
- Change filter element, previously grease new o-ring .
- Grease thread of filter cover, o-ring and back-up ring.
- Reassemble pre-filter cover and filter housing. Note the correct position of th filter back-up!
- Connect pipes and tighten.
- Adjust holding clamp and tighten nuts

The filter element change is now completed.



#### Note

Ensure that the old filter element is disposed correctly at an approved waste point.



Fig. 1 - Loosen pipes and nuts

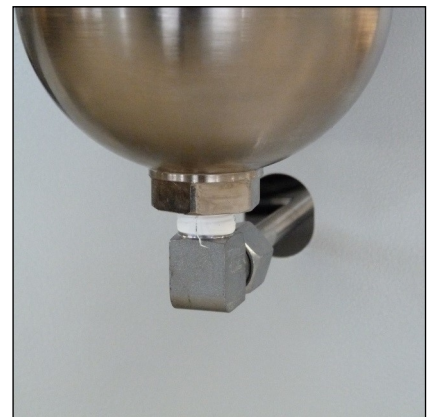

Fig. 2 - Loosen pipes and nuts

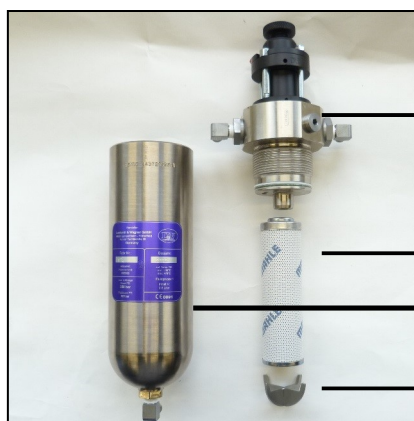

Fig. 4 - 0.8ltr pre-filter parts

Pre-filter cover c/w safety valve, o-ring, back-up ring and connections

Filter element

Pre-filter housing

Filter back-up



Fig. 3 - Open pre-filter cover

## MAINTENANCE AND SERVICE

### 0.8 ltr Pre-Filter Housing - Maintenance



#### Note

Clean all parts thoroughly before assembly.

Pre-filter housing maintenance as follows:

#### Dismount pre-filter housing

- Loosen pipes and nuts
- Remove pre-filter housing

#### Pre-filter housing maintenance

- Open pre-filter cover
- Change o-ring and back-up ring, previously grease both
- Grease thread of filter cover and reassemble pre-filter cover and filter housing

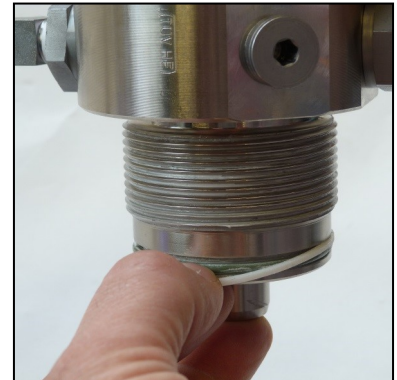

Fig. 1 - Change o-ring and back-up ring

#### Install pre-filter housing

- Connect pipes and tighten.
- Adjust holding clamp and tighten nuts

The pre-filter housing maintenance is now completed.

### Inlet Filters

**Note**

Dirty filters make intaking air difficult and reduce delivery capacity. Risk of compressor overheating.

A micro filter cartridge is used as an air inlet filter. Check air inlet filter regularly or replace if necessary. Defective air inlet filters should be immediately replaced.

### Maintenance Intervals

We recommend that the filter cartridge should be replaced every 1,000 working hours (depending on pollution grade).

### Inlet Filter Cartridge Change

Inlet filter cartridge change as follows:

- Loose nut (Fig.1)
- Remove cover and replace filter cartridge by a new one (Fig.2)
- Assemble intake filter
- Tighten nut

The inlet filter cartridge change is now completed.



(Fig.1) Loose nut

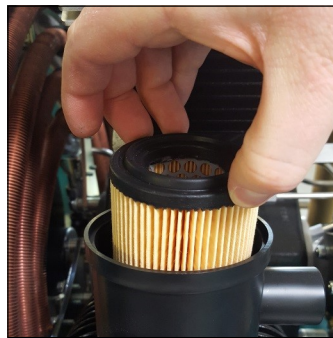

(Fig.2) Remove cover and replace filter cartridge

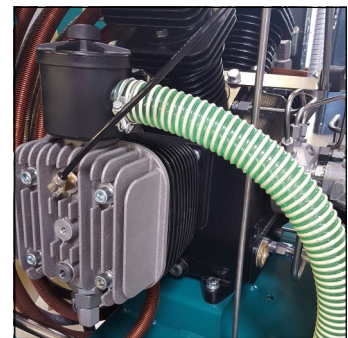

(Fig.3) Mount the intake filter

## MAINTENANCE AND SERVICE

### Cylinder Heads and Valves

In- / outlet valves of the specific compressor stages are located between valve head and cylinder. Outlet valves open while piston upstroke or compression stroke, inlet valves open while downstroke.

Valves are subject to normal wear and tear and have to be replaced at certain intervals (depending on specific operating conditions). Dismount valve heads to change valves. All four valves are combined inlet and outlet valves. The first and second stages consisting of plate valves. On the inlet side the third and fourth stages consists of a membrane disc, on the outlet side of a spring-loaded piston, which sits in a bronze cylinder.

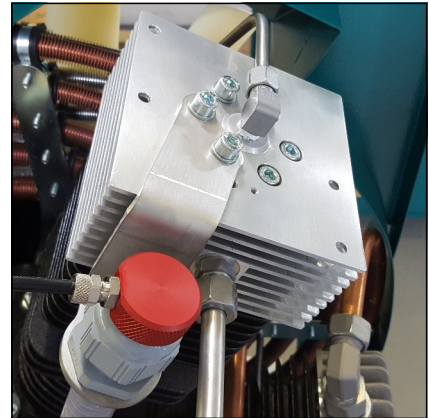

Valve head 3rd stage

A

### Maintenance Intervals

All valves should be replaced after 2,000 working hours due to normal wear and tear. To replace valves the cylinder heads have to be removed. There are no special tools required to replace these valves.

### Available Special Tools

Special tools are not necessary for dismounting inlet and outlet valves but make work easier.

Order number: 006847

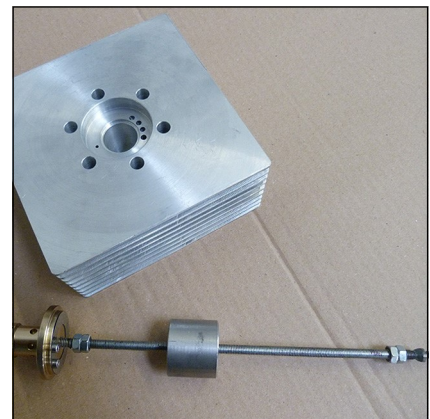

Special tool

## MAINTENANCE AND SERVICE

### Replace In- / Outlet Valves 1st and 2nd Stage



#### Note

The figures of the parts can differ due to the different stages.

Change in- / outlet valves 1st and 2nd stage as follows:

#### Remove in- / outlet valve

- Loose pipes
- Loose valve head screws
- Remove valve head
- Pull out inlet and outlet valve.  
CAUTION: Observe that the lower copper valve ring is also pulled out. (It can still stick inside the cylinder)
- Check valve head if defective

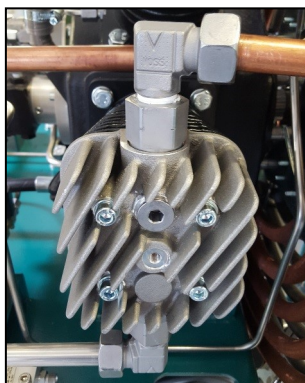

Valve head screws

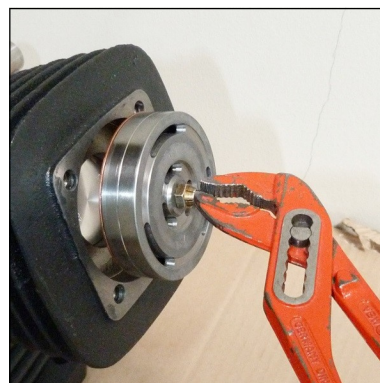

Pull out inlet and outlet valve

Install in- / outlet valve - see following page



### Replace In- / Outlet Valves 1st and 2nd Stage - Continued from previous Page

A



#### Caution

The exact alignment of upper and lower valve gasket is very important. In- / outlet channels have to be exactly centred. Do not turn in- / outlet valve after insertion. The gasket could cover outlet channels.

#### Install In- / Outlet Valve

- Fit the new lower valve gasket on the sealing surface of the cylinder.
- Place the new in- / outlet valve straightly into the cylinder.  
CAUTION: Do not turn the in- / outlet valve inside the cylinder! The in- / outlet channels could be covered!
- Place the upper valve gasket on the in- / outlet valve.  
CAUTION: Observe the correct paper gasket position (centre in- / outlet channels).  
Note: Valve head screws can be inserted into the valve head to secure the upper valve gasket.
- Refit the valve head and tighten the valve head screws crosswise.

#### Starting torques:

1. nd Stage 45 Nm
2. nd Stage 25 Nm

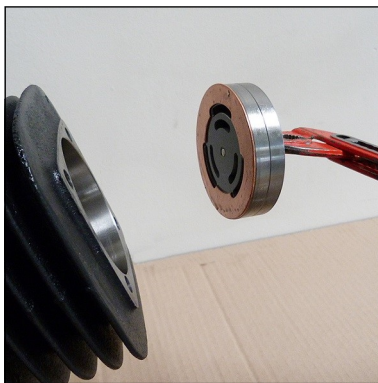

Place new inlet and outlet valve straightly into cylinder

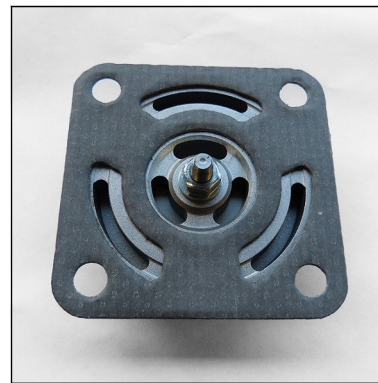

Ensure the correct mounting position of the paper gasket

The replacement inlet and outlet valves 1st and 2nd stage is now completed.

### Replace In- / Outlet Valves 3rd and 4th Stage



#### Note

The figures of the parts can differ due to the different stages.

#### Replacement in- / outlet valves as follows:

- Loose pipes
- Loose valve head screws (Fig. 1)
- Remove lower valve gasket (Fig. 2)
- Dismount in- / outlet valve (Fig. 3). Observe that the upper valve gasket is also pulled out. (It can still stick inside the cylinder head)
- Check valve head if defective (check centre pin)
- Mount valve gasket on in- / outlet valve.  
CAUTION: Ensure correct mounting position of the upper valve gasket (Fig. 4).
- Insert new in- / outlet valve into valve head.  
CAUTION: Observe correct position between valve centre hole and valve head centre pin
- Place lower valve gasket
- Place valve head with the new in- / outlet valve. Tighten valve head screws crosswise (tightening torque 25 Nm)

#### Replacement inlet and outlet valves complete.



Fig. 1 - Loose valve head screws



Fig. 2 - Remove lower valve gasket

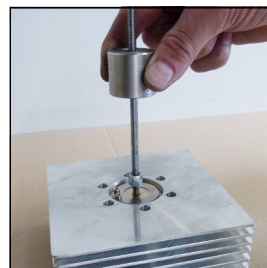

Fig. 3 - Remove in- / outlet valve

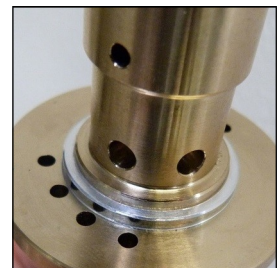

Fig. 4 - Ensure correct mounting position of the upper valve gasket

## MAINTENANCE AND SERVICE

### Replace Piston Rings and Needle Bearings of the 2nd, 3rd and 4th Stage

Replace piston rings and needle bearings of 2nd, 3rd and 4th stage as follows:

- Remove in- & outlet pipework
- Remove valve head bolts
- Remove valve head
- Remove lower valve gasket (see "replace in- / outlet valves 2nd & 3rd stage)
- Check condition of valve head
- Remove flange nuts of compression cylinder
- Take off compression cylinder and o-ring
- Turn crankshaft until piston is on TDC position
- Remove piston rings
- Fit piston rings in accordance to drawing "piston 2nd / 3rd stage" and lubricate by using compressor oil.
- *Remove cylinder flange bolts (only necessary small end bearing needs to be replaced*
- *Take-off guide cylinder*
- *Remove O-ring*
- *Clean sealing surfaces*
- *Remove circlips and piston pin, take-off piston*
- *Remove small end bearing by using L&W special tool (Part number: 006663 / 005456*
- *Fit new small end bearing by using special tool , lubricate bearing*
- *Lubricate piston pin bore*
- *Fit piston to conrod, secure piston pin by circlips*
- *Lubricate and fit O-ring to guide cylinder*
- *Refit guide cylinder*
- *Tighten flange bolts crosswise*
- Lubricate and fit O-ring to compression cylinder
- Lubricate piston skirt
- Compress piston rings by using L&W special tool and pipe wrench. Refit compression cylinder

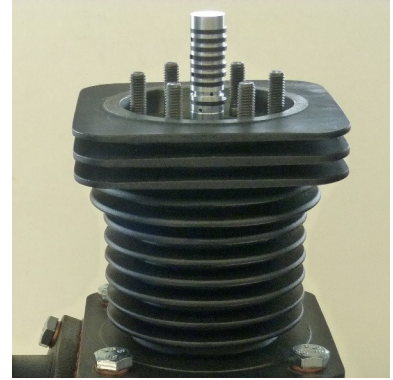

Fig. 1 - take off compression cylinder

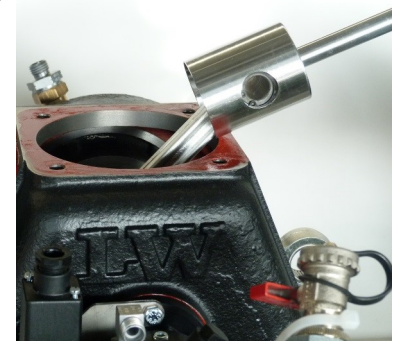

Fig. 2 - Piston 3rd Stage

## MAINTENANCE AND SERVICE

### Change Piston Rings and Needle Bearings of the 2nd, 3rd and 4th Stage - Continue

- Fit washers and nuts, tighten crosswise

See "In- / outlet valves 2nd and 3rd stage" for further instructions



Fig. 1 - Fit Circlip

### L&W special tool

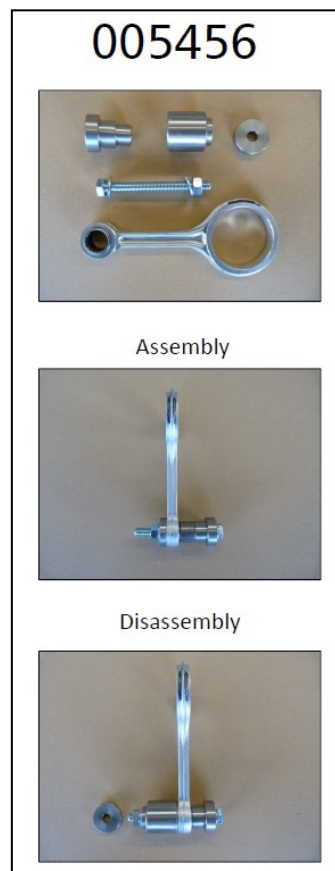

Fig. 2 - L&W special tool for needle bearing 005456

### Safety Valves

Every pressure stage is equipped with a separate over pressure safety valve. Safety Valves avoid a non permissible high pressure at the specific pressure stages and limit maximum operation pressure of the compressor.

Safety valves are adjusted to:

- 1st Stage: 8 bar
- 2nd Stage: 22 bar
- 3rd Stage: 90 bar
- 4th Stage: max. final pressure

The adjusted blow-off pressure [bar] of the safety valves is indicated on their housings.

All safety valves are factory sealed with special L&W safety seals to avoid manipulation of the limit value settings.

Safety valves with removed seals have to be immediately checked for the prescribed settings and replaced if necessary.

The safety valve of the final stage is furthermore equipped with a knurled screw to be activated on-  
ce.

Turning the knurled screw clockwise could vent the valve completely and therefore the final filter housing.

During normal operation conditions, the knurled screw has to be turned anti-clockwise up to the upper stop. An integrated circlip avoids complete unscrewing.

If a safety valve blows off, it indicates problems with either inlet or outlet valve of the following stage.

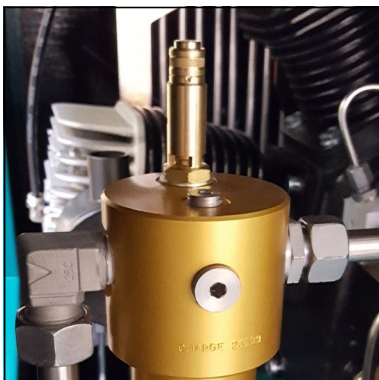

Safety valve 1st stage

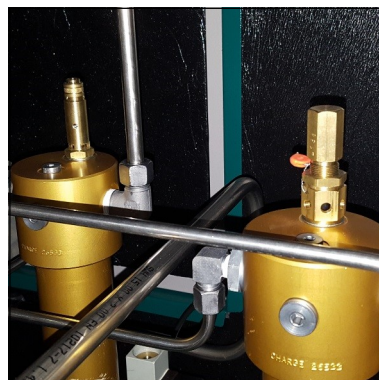

Safety valve 2nd and 3rd stage

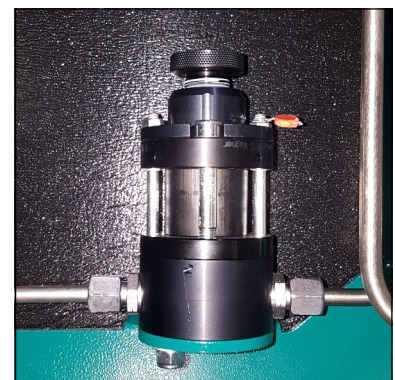

Safety valve 4th stage



#### Note

Replace defective safety valves immediately!

### Pressure Maintaining / Non Return Valve

**Note**

If the adjusted opening pressure of the pressure maintaining valve is higher than the final pressure of the compressor, the final pressure safety valve blows off before pressure maintaining valve opens (final pressure = 0 bar). When valve settings are not clear (e.g. after disassembly / repair), start the adjustment with a low basic setting (turn adjusting screw approx. 3 times in).

A pressure maintaining / non return valve is installed after the filter housing. It maintains a pressure of at least 150-180 bar inside the filter housing - this optimises filter efficiency.

#### Pressure Maintaining Valve

The pressure maintaining valve drains a large part of the water content of the compressed air mechanically by ensuring the minimum outlet pressure. This guarantees optimal drying and purification of the breathing air.

After starting the compressor, the pressure inside the final filter housing constantly increases. The pressure maintaining valve prevents the compressed air from blowing off (final pressure gauge = 0 bar).

When the adjusted opening pressure is reached (150 and 180 bar), the purified compressed air flows via pressure maintaining and non return valve to the filling valve.

The value of the opening pressure of the pressure maintaining valve can be read at the final pressure gauge. When opening pressure is reached, the pressure gauge value increases within a few seconds.



Pressure maintaining/non-return valve

### Safety Valve Test



#### Note

Do not fill any tank during test phase!

#### Safety valve test as follows:

- Disconnect compressor from the electrical power supply and protect against unexpected restart
- Open the cover of the switch box
- Switch on the "Test Safety Valve" switch (pressure switch will be deactivated!)
- Close the cover of the switch box
- Connect the compressor to the electrical power supply
- Close filling valves
- Start the compressor
- Watch the final pressure gauge. The safety valve should open when reaching working pressure of the compressor. If not, switch off the unit and take out of service until the safety valve has been replaced
- Switch off the compressor (Compressor vented)
- Disconnect the compressor from the electrical power supply and protect against unexpected restart
- Open the cover of the switch box
- Switch off the "Test Safety Valve" switch (pressure switch will be activated!)
- Close the cover of the switch box
- Connect the compressor to the electrical power supply

The safety valve test is now completed.

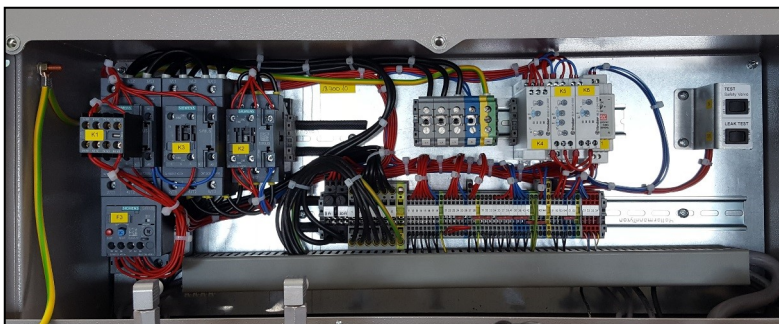

Switch box



Safety valve test switch (up)

### Leak Test



#### Note

Do not fill any tank during test phase!

#### Leak test as follows:

- Disconnect the compressor from the electrical power supply and protect against unexpected restart
- Open the cover of the switch box
- Switch on the leak test switch (solenoid valves will be deactivated!)
- Close the cover of the switch box
- Connect the compressor to the electrical power supply
- Close filling valves
- Start the compressor
- The compressor switches off automatically at the final pressure
- Verify the compressor for release noises. (A slight hiss of the air inlet filter nozzle can be ignored). If release noises occur, localise blow off position(s)
- Disconnect the compressor from the electrical power supply and protect against unexpected restart
- Open the cover of the switch box
- Switch off the leak test switch (solenoids will be activated!)
- Close the cover of the switch box
- Connect the compressor to the electrical power supply (Compressor vented)

The leak test is now completed.

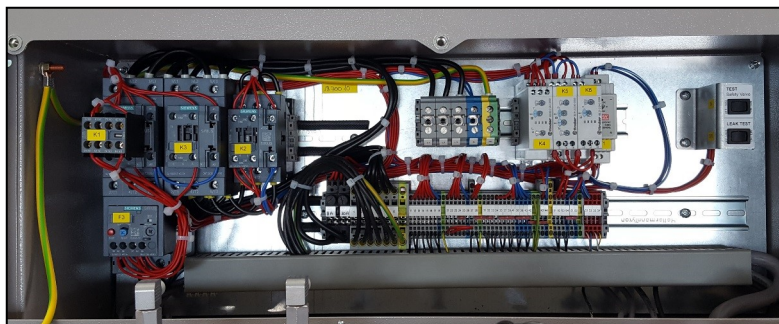

Switch box



Leak test switch (down)



### **Pressure Vessel Test**

According to the Pressure Equipment Directive (PED 97/23/EC) and TÜV Darmstadt (German supervising authorities). State: 10th of December, 2005

Subject: pressure equipment with a product permissible operating pressure [bar] x content volume [litres] from 200 up to 1000.

#### **Example: Filter housing 1.7 l**

Maximum operating pressure: 350 bar

Content volume: 1.7 litres

$350 \text{ bar} \times 1.7 \text{ litres} = 595$

595 is smaller than 1000 -> result: Test is applicable!!

#### **Example: Filter housing 2.3 l**

Maximum operating pressure: 350 bar

Content volume: 2.3 litres

$350 \text{ bar} \times 2.3 \text{ litres} = 805$

805 is smaller than 1000 -> result: Test is applicable!!

### **Pressure equipment from 200 up to 1000 have to be tested as follows:**

#### **1. Examination after 5 years by a qualified person or authorized organisations.**

Visual inspection, inside and outside.

#### **2. Examination after 10 years by a qualified person or authorized organisations.**

Visual inspection, inside and outside.

In addition, a water pressure test is carried out at 1.5 times of the permissible vessel operating pressure.



A

# MAINTENANCE RECORDS



## MAINTENANCE RECORDS

### Introduction form for the Operator

No.	Surname, Name	Date	Place	Signature	Instructor

By adding themselves to this list, the person that signs it confirms having been given a yearly introduction/instruction about the function and operation of the compressor unit. Furthermore, they have been informed about the relevant safety rules and regulations (TRG, DGRL, BetrSichV, GSG, GSGV).

A



## MAINTENANCE RECORDS

---

### Top up Oil, Oil Change

Date	Operating hours	Oil quantity [l]	Name

A



## MAINTENANCE RECORDS

---

### Cartridge Change

Date	Operating hours	Difference	Name

A



**MAINTENANCE RECORDS**

**Maintenance Work**

**A**

Description	Date, signature



**MAINTENANCE RECORDS**

**Replaced Parts**

Designation	Part number	Date, signature

**A**



## STORAGE

---

### Conservation / Storage of the Compressor

If the compressor unit is not to be used for an extended period of time, we recommend to carry out the following work before storage time:

- Run the compressor at 200 bar filling pressure for approximately ten minutes (control the flow with the filling valve to maintain constant pressure).
- Replace compressor oil, open filling valve(s) and run compressor for a few minutes.
- Stop compressor and open drain valves (depending on the compressor type, this may happens automatically). Remove top cap of final filter housing: clean throat, grease o-ring. and throat with a food grade grease or silicone grease. Close filter housing.
- Remove intake filter cartridge and undo intake pipes on all valve heads.
- Start compressor unit. Spray a few drops of compressor oil into intake connectors.
- Stop compressor unit and insert intake filter cartridge. Bring intake pipes back in position and fix connections and nuts. Close filling- and drain valves.
- Store the compressor in a cool dry place free from dust and contamination. A dust cover is recommended as long as condensation can be avoided.
- If compressor unit should be stored for a period of more than one year, an oil change is strongly recommended before it's been re-used.
- Fuel driven units only: fill up fuel tank to top level to avoid corrosion.

### De-Conservation, Commissioning

After the compressor has been stored, the following steps are to be taken:

- If compressor hasn't been used for longer than 12 months, we strongly recommend an oil change before any use.
- Replace intake filter cartridge and check oil level.
- Clean compressor unit, check for foreign objects. Check condition and tension of V-belts, replace if necessary. Check condition of filling hoses, replace if necessary.
- Secure hoses against whipping and open filling valves and run compressor for approximately 10 minutes.
- Check condition of final filter cartridge, replace if necessary.
- Close filling valves and run compressor up to final pressure.
- Check safety valve relief pressure of final stage and/or pressure switch setting.
- Check all connections and pipe work for leaks.

Once all above steps are completed, compressor unit is now ready for use.



## STORAGE

---

### Transportation Instructions

- Parts which need to be dismantled for transport purposes must be carefully replaced and secured before taking into operation.
- The transport may only be carried out by trained personnel.
- For transportation, only use lifting devices and equipment with sufficient lifting power.
- Do not stand or work under suspended loads.
- Also separate from minor relocation machinery / system of any external energy supply. Before recommissioning, reconnect the machine to the mains according to regulations.
- When recommissioning, proceed according to the operating instructions..

### Disposal

The product must be disposed in accordance with national waste disposal regulations and by an appropriate waste disposal company.

### Electric and Electronic Components

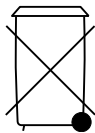

EU-wide regulations for the disposal of electric and electronic appliances which have been defined in the EU Directive 2002/96/EC and in national laws are effective from August 2005 and apply to this device.

Common household appliances can be disposed by using special collecting and recycling facilities. However, as this device has not been registered for household usage, it must not be disposed of through these means.

The device can be returned to L&W. Please do not hesitate to contact us if you have any further questions on this issue.

# Operating Instructions

## ECC - Electronic compressor control





## TABLE OF CONTENTS

---

### General Information

General Information .....	3
Description of Warning Symbols .....	3

### Description

Specifications / Options .....	4
Switchboard .....	5

### Operation and Function

Main Menu .....	6
Selection Menu (M100) .....	7
Display Menu (M200) .....	8
Inter-Stage Pressure Display.....	8
Display II (M270) .....	9
Settings Menu (M300).....	10
Set Stop Pressure - automatic mode (M320).....	11
Set Restart Pressure - automatic mode (M330).....	11
Set Stop Pressure - semi-automatic mode (M340) .....	11
Test Menu (M400) .....	12
Test Solenoids (M420) .....	12
Test safety valve (M430) .....	13
Test stop without venting (M440) .....	13
Statistics Menu (M500).....	14
Maintenance Menu (M600) .....	15
Confirm Maintenance (M680).....	16
Operation Mode (M700).....	17
Language Menu (M750) .....	17
Adjusting Display Backlight.....	18
Software Update .....	18
Spare part lists.....	19
Manufacturer in terms of 97/23/EC.....	20

**B**

## GENERAL INFORMATION

---

### General Information

We strongly recommend reading this manual thoroughly prior to operation and follow all the safety precautions precisely. Damage resulting from any deviation from these instructions is excluded from warranty and liability for this product. Carry out other commissioning steps only if you have fully understood the following contents.

Before commissioning and using the unit, carry out all the essential preliminary work and measures concerning legal regulations and safety. These are described on the following pages of this operation manual.

**B**

### Description of marks and warning signs

The following warning signs are used in this document to identify the corresponding warning notes which require particular attention by the user. The warning signs are defined as follows:



#### Caution

Indicates an imminently hazardous situation which, if not avoided, could result in serious injury, physical injury or death.



#### Warning

Indicates a potentially hazardous situation which, if not avoided, could result in physical injury or damage to the product or environment.



#### Note

Indicates additional information on how to use the unit.



## DESCRIPTION

---

### Specifications and Options

All L&W compressors can be optionally equipped with the all-electrical computer supported control system "ECC". It is easy to operate and allows multiple and individual settings.

#### Specifications

- LCD-Display with key pad
- Automatic & semi-automatic operation mode
- Automatic dump system
- Integrated counter for operation hours
- Integrated counter for load cycles
- Maintenance intervals automatically displayed
- Required service part numbers automatically displayed
- Fully adjustable pressure ranges for start and stop
- Warning messages ("Housing Open" / "Emergency Switch")
- Check of end-pressure safety valve possible
- Auto switch-off when system is not running
- Extendable by additional modules (e.g. external filling panel)
- Easy to operate menu
- Door position switch (housing open message)
- Load-free or depressurised start cycles

#### Options

- Oil pressure control
- Oil temperature control
- Cylinder head temperature control
- Inter stage pressure monitoring
- PIN controlled access
- Master / slave option (if more than one ECC equipped compressors are combined)

## DESCRIPTION

### Switchboard



No.	Description
1	LCD Display
2	Key Pad
3	LED Display (Compressor OFF)
4	LED Display (Power)
5	LED Display (Compressor ON)



## OPERATION AND FUNCTION

### Main Menu

Immediately after the compressor has been connected to power, the ECC-display shows the following Main Menu::

Charging	0 min
Total	0,0 h
Start : 1	Stop : 0
Help: *	OFF
Final Press	<b>0</b> bar

Present filling time in minutes

Total operation hours

Key 1 to start compressor / Key 0 to stop compressor

\* Key leads to submenus Current operation state = Off

Present filling pressure

**B**

### The following keys can now be used:

Key	Function / Description
1	Start - Starts the compressor
0	Stop - Stops the compressor
*	Leads to the submenus

After typing the \* key the following Selection Menu appears.



## OPERATION AND FUNCTION

---

### Selection Menu (M100)

After typing the \* key in the Main Menu the following Selection Menu appears.

Selection:		
2	Display	Key 2 leads to submenu "Display"
3	Settings	Key 3 leads to submenu "Settings"
4	Test	Key 4 leads to submenu "Test"
5	Statistics	Key 5 leads to submenu "Statistics"
6	Maintenance	Key 6 leads to submenu "Maintenance"
7	Operation Mode	Key 7 leads to submenu "Operation mode"
(M100)	Return : #	Key # leads back to "Main Menu"

(M100) tells that you are currently on menu page 100.



#### Note

At any time, the unit can be started with key 1 or shut down with key 0.  
Caution: Risk of accident during maintenance work!

B



## OPERATION AND FUNCTION

### Display Menu (M200)

Pushing key 2 in the Selection Menu leads to Submenu "Display".

Display I:	
2	Press. Stage 1
3	Press. Stage 2
4	Press. Stage 3
5	Cyl. Head Temp.
6	Oil Temp.
7	Display II
(M200)	Return : #

Key 2 shows current pressure of the 1st stage\*

Key 3 shows current pressure of the 2nd stage

Key 4 shows current pressure of the 3rd stage

Key 5 shows temperature of the final stage cylinder head

Key 6 shows the oil temperature

Key 7 shows Display II

Key # leads back to "Main Menu"

(M200) tells that you are currently on menu page 200.

By pushing key 2 (inter-stage pressure 1) the following Display appears.

### Inter-Stage Pressure Display

Pushing key 2 in the Display Menu leads to the Inter-Stage Pressure 1 Display Menu.

Charging	0 min
Total	0,0 h
Start: 1	Stop: 0
Help:*	OFF
Press.	0 bar
1 <sup>st</sup> Stage	0,0 bar

Use keys 3 to 6 in the Menu "Display I" to change between the displayed values.



#### Note

Pushing key 8 in the display menu "Display II" leads to the option "Pressure200/300" for compressors with 2 filling pressures. Displayed in field 3 of the display menu "Display I".



## OPERATION AND FUNCTION

---

### Display II (M270)

Pushing key 7 in the Selection Menu leads to Menu "Display II".

#### Display II:

Press.	Temp.
4: 0	C: 0
5: 0	D: 0
6: 0	E: 0
7: 0	F: 0
bar	°C
(M270)	Return : #

This display shows further customer specific pressure and temperature values.

Key # leads back to "Main Menu"

**B**

## OPERATION AND FUNCTION

---

### Settings Menu (M300)

Pushing key 3 in the Selection Menu leads to the Settings Menu.

<b>Settings:</b>	
<b>Automatic</b>	
2	Stop pressure
3	Restart Press.
<b>Semi-Automatic</b>	
4	Stop Pressure
9	Close
(M300)	Return : #

Key 2 leads to submenu „Set Stop Pressure“

Key 3 leads to submenu „Set Restart Pressure“

Key 4 leads to submenu „Set Stop Pressure“

Key 9 leads back to submenu "Selection"

Key # leads back to "Main Menu"

Use menu M700 to change between "Automatic" and "Semi-Automatic" mode.

Restart pressure can only be set in "Automatic Mode".

Prior to setting the pressure, start the safety valve test.



#### Attention during maintenance

During automatic mode, the compressor can automatically start by itself at any time, depending on the selected restart pressure (see "Set Restart Pressure" M330).



## OPERATION AND FUNCTION

---

### Set Stop Pressure - automatic mode (M320)

Only valid in automatic mode, see menu M700.

**Set**  
**Stop Pressure:**  
Actual: 330 bar  
7 New Value:  
>> XXX bar  
4 (050,, 333)  
8 Confirm  
(M320) Return : #

Current restart pressure  
Key 7 if restart pressure should be changed  
XXX indicates modified stop pressure  
Chooseable pressure range for restart pressure  
Key 8 confirms new restart pressure  
Key # leads back to "Main Menu"

**B**

### Set Restart Pressure - automatic mode (M330)

Only valid in automatic mode, see menu M700.

**Set**  
**Restart Pressure:**  
Actual: 180 bar  
7 New Value:  
>> XXX bar  
4 (030,, 310)  
8 Confirm  
(M330) Return : #

Current restart pressure  
Key 7 if restart pressure should be changed  
XXX indicates modified restart pressure  
Chooseable pressure range for restart pressure  
Key 8 confirms new restart pressure  
Key # leads back to "Main Menu"

### Set Stop Pressure - semi-automatic mode (M340)

Only valid in semi-automatic mode, see menu M700.

**Set**  
**Stop Pressure:**  
Actual: 180 bar  
7 New Value:  
>> XXX bar  
4 (030,, 310)  
8 Confirm  
(M340) Return : #

Current stop pressure  
Key 7 if stop pressure should be changed  
XXX indicates modified stop pressure  
Chooseable pressure range for stop pressure  
Key 8 confirms new restart pressure  
Key # leads back to "Main Menu"

## OPERATION AND FUNCTION

### Test Menu (M400)

Pushing key 4 in the Selection Menu leads to the Test Menu.

Test:	
2	Solenoids
3	Safety Valve
4	Test-Stop
9	Close
(M400)	Return : #

Key 2 leads to submenu "Test Solenoids"

Key 3 leads to submenu "Test Safety Valve"

Key 4 leads to submenu "Test Stop without Venting"

Key 9 leads back to submenu "Selection"

Key # leads back to "Main Menu"

**B**

### Test Solenoids (M420)

Pushing key 2 in the Selection Menu leads to Submenu "Test Solenoids".

Test Solenoids	
3	open
7	close
9	Close
(M420)	Return : #

Key 3 opens solenoids

Key 7 closes solenoids

Key 9 leads back to submenu „Test“

Key # leads back to "Main Menu"



#### Note

This menu can not be left unless solenoids have been closed by key 7.

## OPERATION AND FUNCTION

### Test safety valve (M430)

Pushing key 3 in the Test Menu leads to Submenu "Test Safety Valve".



#### Note

Prior to starting the Test, close all filling connections (also connected filling panels if necessary). During this test, the compressor passes the selected stop pressure (see Menu M320) to test the correct function of the final pressure safety valve. This would limit the maximum operating over pressure of the unit in case of malfunction.

B

**Test**

**Safety Valve**

Close Filling Valves!

5 Start	0 Stop
9 Close	
(M430) Return : #	

Key 5 to start test      Key 0 to stop test

Key 9 leads back to submenu „Test“

Key # leads back to "Main Menu"

### Test stop without venting (M440)

Pushing key 4 in the Test Menu leads to Menu "Test Stop without Venting".



#### Note

This test is only operable when the compressor has been started with key 1. This test mainly checks the leak tightness of pressure vessels, pressurised pipes, safety valves and the compressor block.

**Test**

**stop without venting:**

5 Stop	
6 Vent	
Pressure	0
	bar
9 Close	
(M440) Return : #	

Key 5 stops compressor during test run

Key 6 vents compressor after leak search has been finished

Shows current filling pressure

Key 9 leads back to submenu „Test“

Key # leads back to "Main Menu"



## OPERATION AND FUNCTION

---

### Statistics Menu (M500)

Pushing key 5 in the Selection Menu leads to Submenu "Statistics".

Statistics	
Operation Hours:	0,0 h
Start cycles:	00
Max Press	000 bar
9 Close	
(M500) Return : #	

Total operation hours of compressor unit

Total number of compressor starts

Maximum working pressure of unit (set by safety valve test)

Key 9 leads back to submenu „Selection“

Key # leads back to "Main Menu"

Push key 5 to get information on which ECC software version is currently installed on your system (M505), i.e.: By pushing key 2, the total load cycles of the filter housing are being indicated.

B

## OPERATION AND FUNCTION

---

### Maintenance Menu (M600)

Pushing key 6 in the Selection Menu leads to the "Maintenance Menu".

Hours remaining		
Oil change	14 h	Shows remaining hours of listed components (i.e. next oil change in 14 hours,...)
Sinter filt	989 h	
Silencer	4989 h	
Valves	5989 h	
Oil filter	1000 h	
8 Change done		Key 8 leads to submenu "Receipt Maintenance"
9 Close		Key 9 leads back to submenu „Selection“
(M600) Return : #		Key # leads back to "Main Menu"

Remaining hours depend on the type. At the end of any remaining hours, the display indicates a warning message. Furthermore, the display informs about any possibly necessary spare parts with the corresponding L&W service part number.



#### Attention during maintenance

During automatic mode, the compressor can automatically start by itself at any time, depending on the selected restart pressure (see "Set Restart Pressure" M330).





## OPERATION AND FUNCTION

---

### Confirm Maintenance (M680)

Confirm Maintenance	
2	Oil change
3	Sinter filters
4	Silencer
5	Valves
6	Oil filter
(M680)	Return : #

Key 2 receipts oil change  
Key 3 receipts change of sinter filters  
Key 4 receipts change of silencer  
Key 5 receipts change of valves  
Key 6 receipts oil filter  
Key # leads back to "Main Menu"

**B**

Display confirms any reset of "Hours remaining" with the following message:

Confirm Maintenance	
Operation Hours Meter Set	
9	Close
(M680)	Return : #

Key 9 leads back to submenu "Hours remaining"  
Key # leads back to "Main Menu"



## OPERATION AND FUNCTION

---

### Operation Mode (M700)

Pushing key 7 in the Selection Menu leads to the menu "Operation Mode".

Activated modes are always displayed in bolt letters (above example: **Semi-Automatic**).

Further settings can be made in the Settings Menu (M300).

**B**

Betriebsart:	
2	Automatic
3	<b>Semi-Automatic</b>
4	bar /mpa
5	Sprache
9	Close
(M700)	Return : #

Key 2 activates automatic mode

Key 3 activates semi-automatic mode

Key 4 selects between bar and MPa (optional)

Key 5 leads to the "Language Menu"

Key 9 leads back to submenu „Selection“

Key # leads back to "Main Menu"

### Language Menu (M750)

Language Menu	
2	German
3	English
4	French
5	Spanish
6	Dutch
7	Language II
(M750)	Return : #

Key 7 optional language (e.g. Chinese)

Key # leads back to "Main Menu"

## OPERATION AND FUNCTION

---

### Adjusting Display Backlight

The brightness of the display can be adjusted with an adjusting screw on the back of the control.

### Software Update

Software updates can only be carried out by L&W. To carry out an update, the device has to be send to the L&W service.

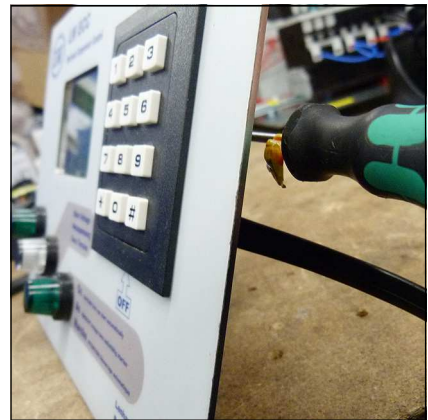

Adjust brightness

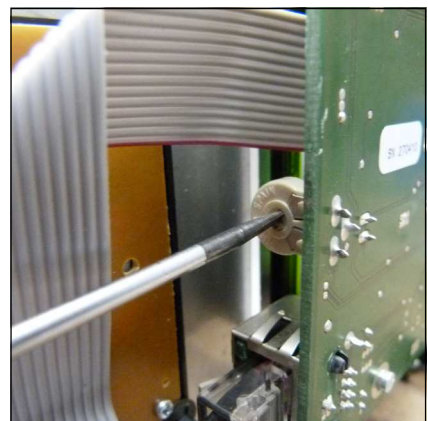

Adjust brightness

## SPARE PART LISTS

Best.-Nr. / Order No.	Benennung	Description
002141	1. Stufe Druckaufnehmer 0-10 bar	1st stage pressure sensor 0-10 bar
002142	2. Stufe Druckaufnehmer 0-60 bar	2nd stage pressure sensor 0-60 bar
003888	3. Stufe Druckaufnehmer 0-100 bar	3rd stage pressure sensor 0-100 bar
002143	Endstufe Druckaufnehmer 0-400 bar	Final stage pressure sensor 0-400 bar
006890	Druckaufnehmer 420 bar Version 0-600 bar	Pressure sensor 420 bar version 0-600 bar
004840	Öldruckaufnehmer 0-6 bar	Oil pressure sensor 0-6 bar
006912	Öltemperatursensor	Oil temperature sensor
003501	Zylinderkopf - Temperatursensor	Cylinderhead temperature sensor

**B**



002141 / 002142 / 002143 / 003888 / 004840  
Druckaufnehmer / Pressure sensor



006890 - Druckaufnehmer 420 bar /  
Pressure sensor 420 bar



006912 - Öltemperatursensor  
Oil temperature sensor



003501 - Zylinderkopf - Temperatursensor  
Cylinderhead temperature sensor



**LENHARDT & WAGNER GMBH**

---

**B**

**Manufacturer in terms of 97/23/EC**

The full name and address of the manufacturer is:

Lenhardt & Wagner GmbH

An der Tuchbleiche 39  
68623 Hüttenfeld / Germany

Phone: +49 (0) 62 56 - 85 88 0 - 0

Fax: +49 (0) 62 56 - 85 88 0 - 14

E-Mail: [service@lw-compressors.com](mailto:service@lw-compressors.com)

Internet: [www.lw-compressors.com](http://www.lw-compressors.com)





**ERSATZTEILLISTEN / SPARE PARTS LISTS  
DETAILANSICHTEN / DETAILED VIEWS**

C



## **Inhaltsverzeichnis**

---

Bedienpaneel - Dashboard .....	1
Gehäuse - Housing .....	4
Rohrleitungssystem - Pipework.....	8
Kompressorblock - Compressor Block .....	12
Kurbelwelle - Crankshaft .....	16
Kolben 1. Stufe - Piston 1st Stage .....	18
Kolben 2. Stufe - Piston 2nd Stage.....	20
Kolben 3. Stufe - Piston 3rd Stage .....	22
Kolben 4. Stufe - Piston 4th Stage .....	24
Ventil 1. & 2. Stufe - Valve 1st & 2nd Stage .....	26
Ventil 3. Stufe - Valve 3rd Stage .....	28
Ventil 4. Stufe - Valve 4th Stage .....	30
Kühler 1. Stufe - Cooler 1st Stage .....	32
Kühler 2. Stufe - Cooler 2nd Stage .....	35
Kühler 3. Stufe - Cooler 3rd Stage.....	37
Kühler 4. Stufe - Cooler 4th Stage.....	39
Ölpumpe - Oil Pump .....	42
Ölablassschlauch - Oil Drainage Tube .....	44
Ansaugfilter - Air Intake Filter .....	46
Lüfterrad - Cooling Fan .....	48
Öl- Wasserabscheider 1. Stufe - Oil- Water Separator 1st Stage .....	50
Öl- Wasserabscheider 2. Stufe - Oil- Water Separator 2nd Stage.....	52
Öl- Wasserabscheider 3. Stufe - Oil- Water Separator 3rd Stage.....	54
Filter 0,8l - Filter 0.8ltr.....	56
Magnetventil mit Rückschlagventil - Solenoid Valve with Non-Return Valve .....	58

---



## **Inhaltsverzeichnis**

---

Filtergehäuse 2,3 l - Filter Housing 2.3 ltr .....	60
Kondensat-Stopp-Ventil - Condensate-Stop-Valve .....	62
Kondensat-Stopp-Ventil-Gehäuse - Condensate-Stop-Valve-Housing .....	64
Verteilerblock - Distributor Block .....	66
Kondensat-Sammelbehälter - Condensate-Catch-Tank .....	68
Sicherheitsventil - Safety Valve .....	70
Pneumatisches Kondensatventil - Pneumatic Condensate Valve .....	72
Druckhalte- Rückschlagventil - Pressure Maintaining- Non-Return Valve .....	74
Druckschalter - Pressure Switch .....	76
Motor - Engine - Microsoft Publisher .....	78

---





## ERSATZTEILLISTE / SPARE PART LIST

### Baugruppe: Bedienpaneel / Assembly: Dashboard

Best.-Nr. / Order No.	Benennung	Description
000663	Einbaumanometer mit Befestigungsbügel	Press. Gauge c/w fixing strap
002089	Betriebsstundenzähler 230 Volt	Hour counter 230 V
002502	Taster, kompl. Farbe: blau	Button blue - condensate test
002504	Taster, kompl., Farbe: grün	Start Button, colour green
002506	Einbaumanometer 0-250 bar	Pressure Gauge 0-250bar
003121	Not-Aus Schalter komplett	Emergency switch compl.
004169	Manometerschlauch 1000 mm	Pressure Hose, length:1000 mm
008153	Taster rot, komplett, inkl. LED Leuchte	Button, colour: red, c/w LED
010801	Armaturenblech 1 Manometer	Dash Panel - 1 Gauge
010932	Filterlüfter für Elektroschaltkasten	Filter Fan for Switch Box

**DETAILANSICHT / DETAILED VIEW**

**Baugruppe: Bedienpaneel / Assembly: Dashboard**

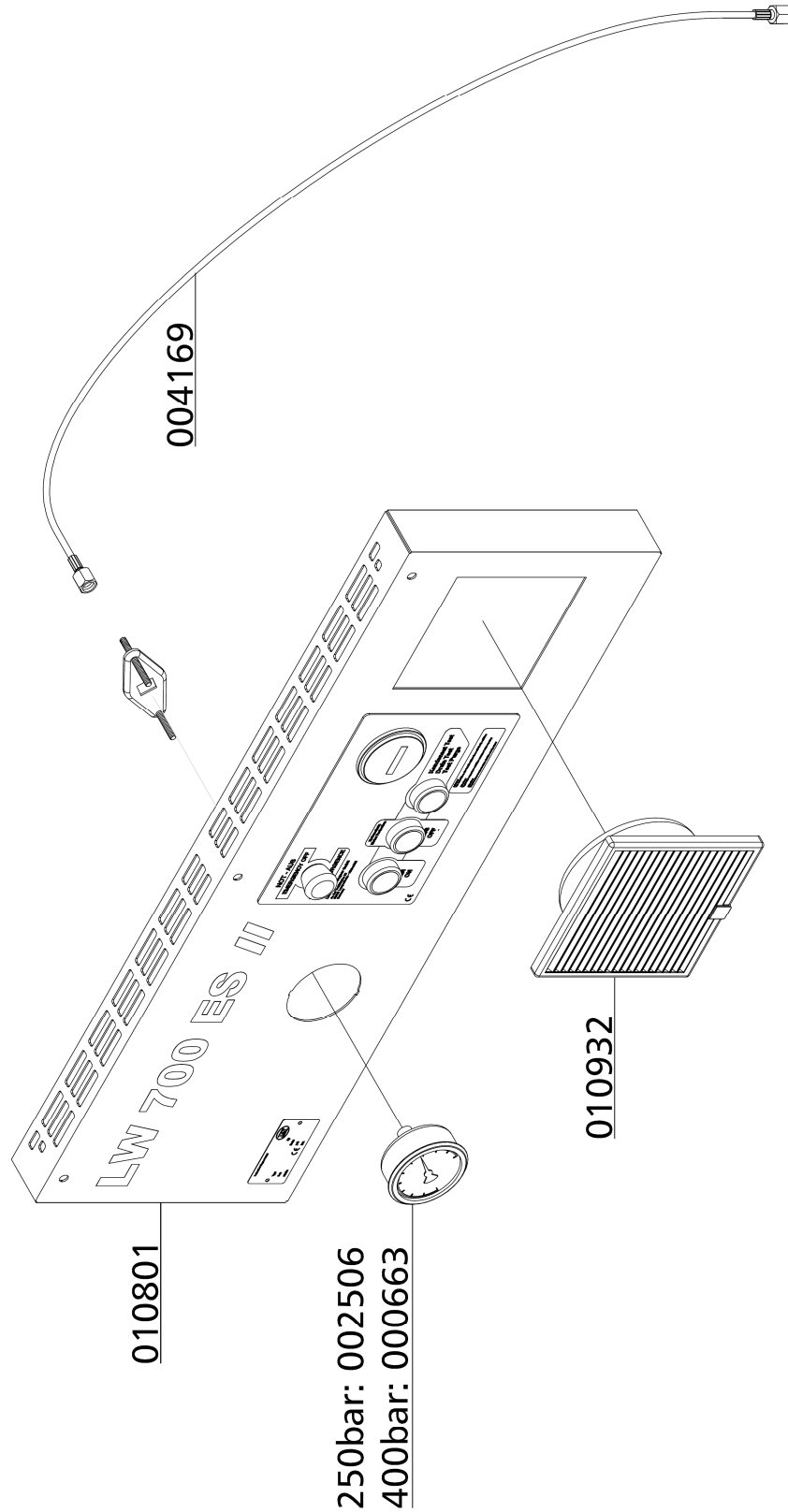

C

**DETAILANSICHT / DETAILED VIEW**

**Baugruppe: Bedienpaneel / Assembly: Dashboard**

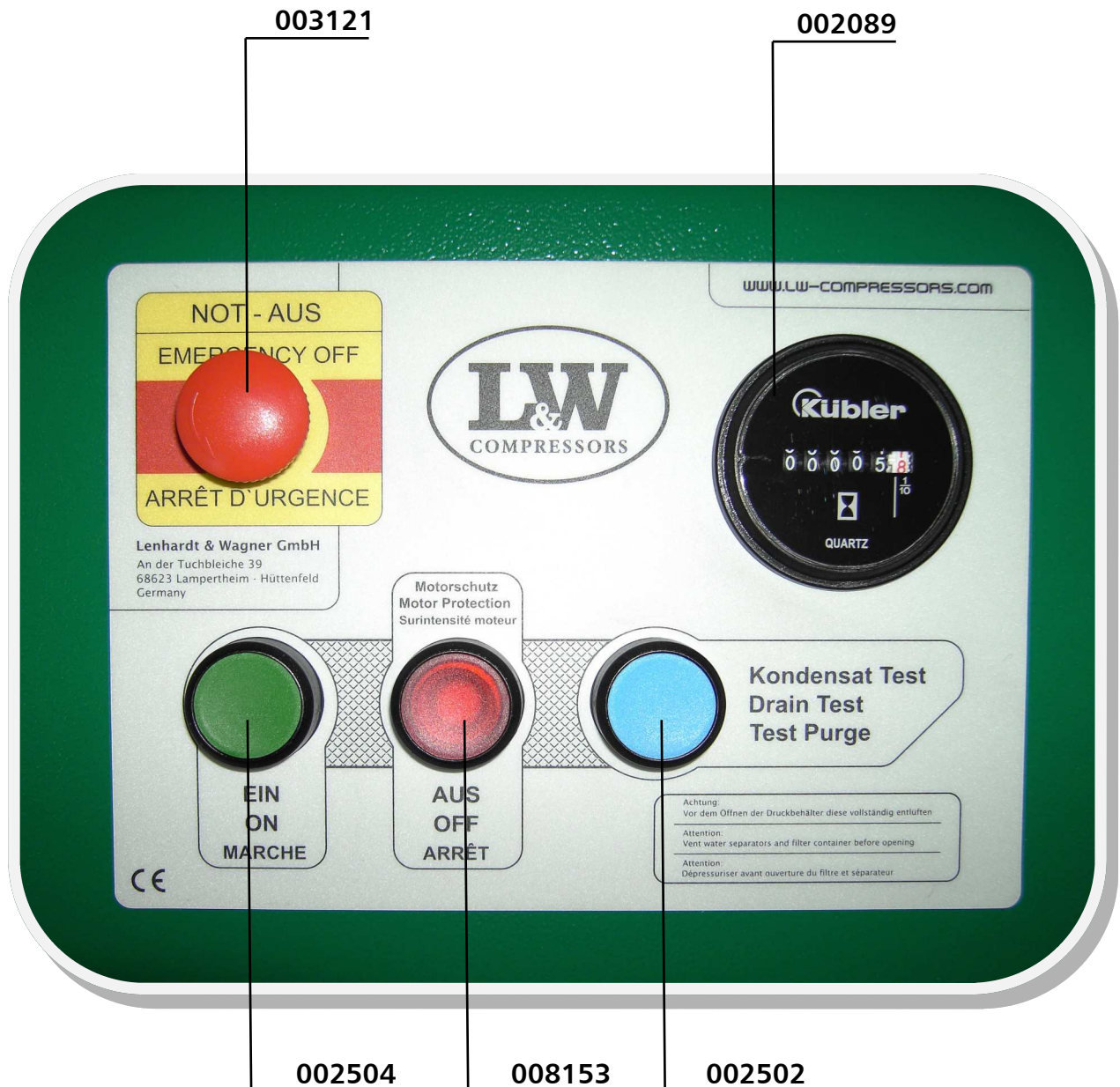

C

## ERSATZTEILLISTE / SPARE PART LIST

### Baugruppe: Gehäuse / Assembly: Housing

Best.-Nr. / Order No.	Benennung	Description
000498	U-Scheibe A6	Washer A6
001028	Zylinderschraube	Allen Bolt
001030	Zylinderschraube	Allen Bolt
001052	Senkkopfschraube	Slotted Counter Sunk Screw
001101	6-kant Schraube	Hexagon Screw
001152	Stoppmutter	Lock Nut M5
001156	Stoppmutter	Lock Nut M6
001163	Mutter	Nut M10
001176	U-Scheibe A5	Washer A5
001178	U-Scheibe A6	Washer A6
001186	U-Scheibe A10	Washer A10
001190	Federring A10	Spring Washer A10
001677	Griffschale PVC-Schwarz	Plastic Snatch, PVC, black
002551	Vorreiber komplett	Housing Lock (ES Models)
005437	Standfuß, Höhenverstell. mit Gummieinl.	Foot, Height adjustable Ø80 mm
005839	Linsenflanschschraube mit Innensechskant	Lens Head Screw
005841	Linsenflanschschraube mit Innensechskant	Lens Head Screw
005842	Linsenflanschschraube mit Innensechskant	Lens Head Screw
005848	Sterngriffschraube ES Gehäuse	Star Grip Bolt
005889	Scharnier Armaturenblech	Dash board hinge, 5-piece unit
006164	Befestigungsklammer Griffschale	Clip for Moulded Recess
006431	Seitenteil rechts	Side-Panel, right hand side
006433	Wartungsdeckel	Service Cover
006434	Tür vorne	Front Door
006436	Abdeckung vorne	Front Cover
006439	Abdeckung hinten	Rear Cover
006440	Querboden oben	Top Transverse
006441	Deckel oben	Top Cover
008655	Linsenflanschschraube mit Innensechskant	Lens Head Screw



## ERSATZTEILLISTE / SPARE PART LIST

### Baugruppe: Gehäuse / Assembly: Housing

Best.-Nr. / Order No.	Benennung	Description
009216	Tür hinten	Rear door
009514	Ventilatorring, Wandring	Cowl
009600	U-Scheibe	Washer
009691	Ventilatorblech Antriebsmotor	Sheet, fan
010406	Windleitblech Kompressorblock	Wind Guide
010667	Grundgestell LW 700 ES II	Main Frame LW 700 ES II
010668	Kompressorplatte LW 700 ES II	Compressor Base Plate
010671	Querboden unten	Transverse Bottom
010672	Seitenteil links	Side-Panel, left hand side
010673	Abdeckung Wartungsöffnung	Cover Services Opening
010685	Dämmmatten/Isoliersatz kompl. Satz	Sound Isolating Mats
010801	Armaturenblech 1 Manometer	Dash Panel - 1 Gauge
010835	Linsenflanschschraube M6x60	Lens Head Screw M6x60
010974	Elektroschaltkasten mit Rahmen	Switch Box

C

**DETAILANSICHT / DETAILED VIEW**

**Baugruppe: Gehäuse / Assembly: Housing**

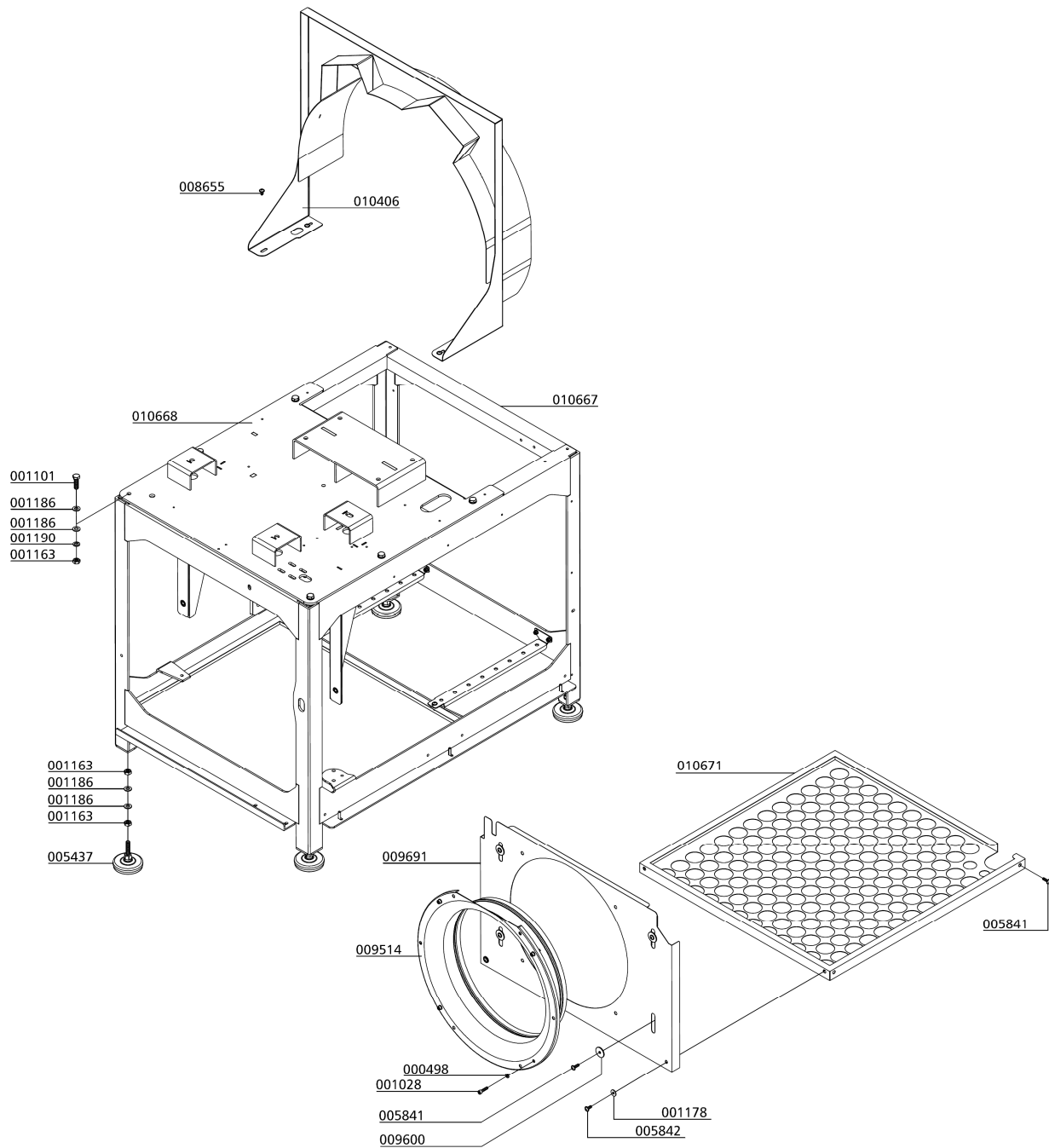

C

# DETAILANSICHT / DETAILED VIEW

## Baugruppe: Gehäuse / Assembly: Housing

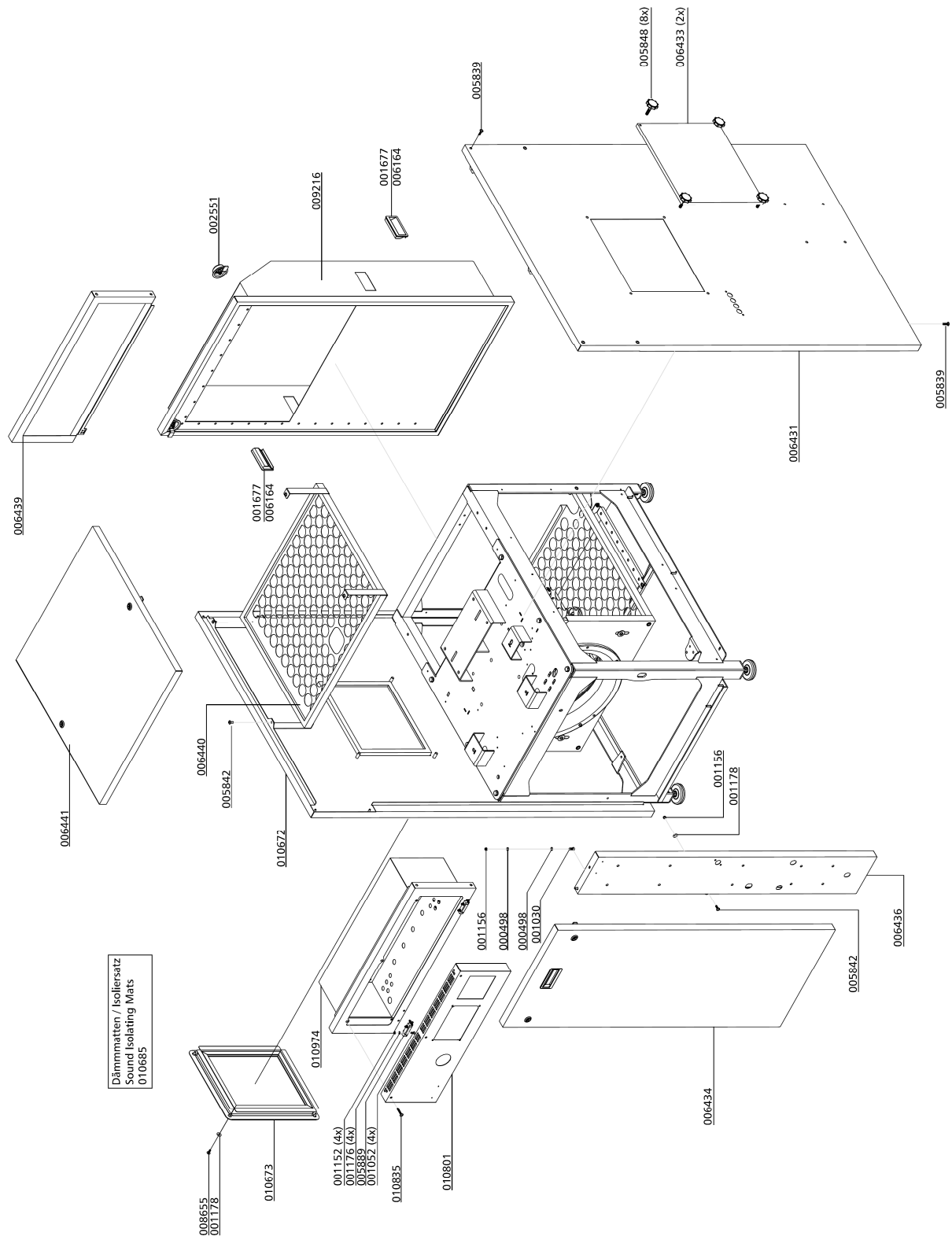

C



## ERSATZTEILLISTE / SPARE PART LIST

### Rohrleitungssystem / Pipework

Best.-Nr. / Order No.	Benennung	Description
000216	Halteklötz, Alu	Alloy Fixing Block
000498	U-Scheibe A6	Washer A6
000509	Zylinderschraube	Allen Bolt
000628	Einfachselle 1 x 8mm 1 Paar	Pipe Clamp 1x8mm 1pair PVC
000629	Doppelschelle 2 x 8mm 1 Paar	Pipe Clamp 2x8mm - 1 pair
000638	Doppelschelle 2 x 8 mm 1 Paar	Pipe Clamp 2x8mm - 1 pair
000735	Gerade Verschraubung	Connection
000738	Gerade Verschraubung	Straight Connection
000783	Verschraubung	Straight Connection
000838	Verschlussstopfen	Plug
001026	Zylinderschraube	Allen Bolt
001027	Zylinderschraube	Allen Bolt
001028	Zylinderschraube	Allen Bolt
001156	Stopfmutter	Lock Nut M6
001443	Hochdruckschlauch	HP Hose
008995	Winkelverschraubung	Elbow Connection
010006	Kondensatschlauch, Ø8x1,5, L: 498mm	Condensate Hose Ø8x498mm
010007	Kondensatschlauch, Ø8x1,5, L: 620mm	Condensate Hose Ø8x620mm
010008	Kondensatschlauch, Ø8x1,5, L: 458mm	Condensate Hose Ø8x458mm
010009	Kondensatschlauch, Ø8x1,5, L: 490mm	Condensate Hose Ø8x490mm
010043	Rohrleitung Ø15mm, komplett mit M.& S.	Pipe Ø15mm
010044	Rohrleitung Ø12mm, komplett mit M.&S.	Pipe Ø12mm
010046	Rohrleitung Ø8mm, komplett mit M.&S.	Pipe Ø8mm
010049	Rohrleitung Ø8mm, komplett mit M.&S.	Pipe Ø8mm
010050	Rohrleitung Ø6mm, komplett mit M.&S.	Pipe Ø6mm
010051	Rohrleitung Ø8mm, komplett mit M.&S.	Pipe Ø8mm
010052	Rohrleitung Ø8mm, komplett mit M.&S.	Pipe Ø8mm
010053	Rohrleitung Ø8mm, komplett mit M.&S.	Pipe Ø8mm
010692	Rohrschelle 1x8mm	Pipe Clamp 1x8mm

C





## ERSATZTEILLISTE / SPARE PART LIST

### Rohrleitungssystem / Pipework

Best.-Nr. / Order No.	Benennung	Description
010711	Rohrleitung Ø18mm, komplett mit M.&S.	Pipe Ø18mm
010712	Rohrleitung Ø8mm, komplett mit M.&S.	Pipe Ø8mm
010713	Rohrleitung Ø8mm, komplett mit M.&S.	Pipe Ø8mm
010715	Rohrleitung Ø8mm, komplett mit M.&S.	Pipe Ø8mm
010956	Halter Rohrleitung Ø8mm	Pipe Holder Ø8mm
010975	Rohrleitung Ø8mm, komplett mit M.&S.	Pipe Ø8mm
010976	Rohrleitung Ø8mm, komplett mit M.&S.	Pipe Ø8mm
010978	Rohrleitung Ø8mm, komplett mit M.&S.	Pipe Ø8mm
010979	Rohrleitung Ø8mm, komplett mit M.&S.	Pipe Ø8mm

C

**DETAILANSICHT / DETAILED VIEW**

**Rohrleitungssystem / Pipework**

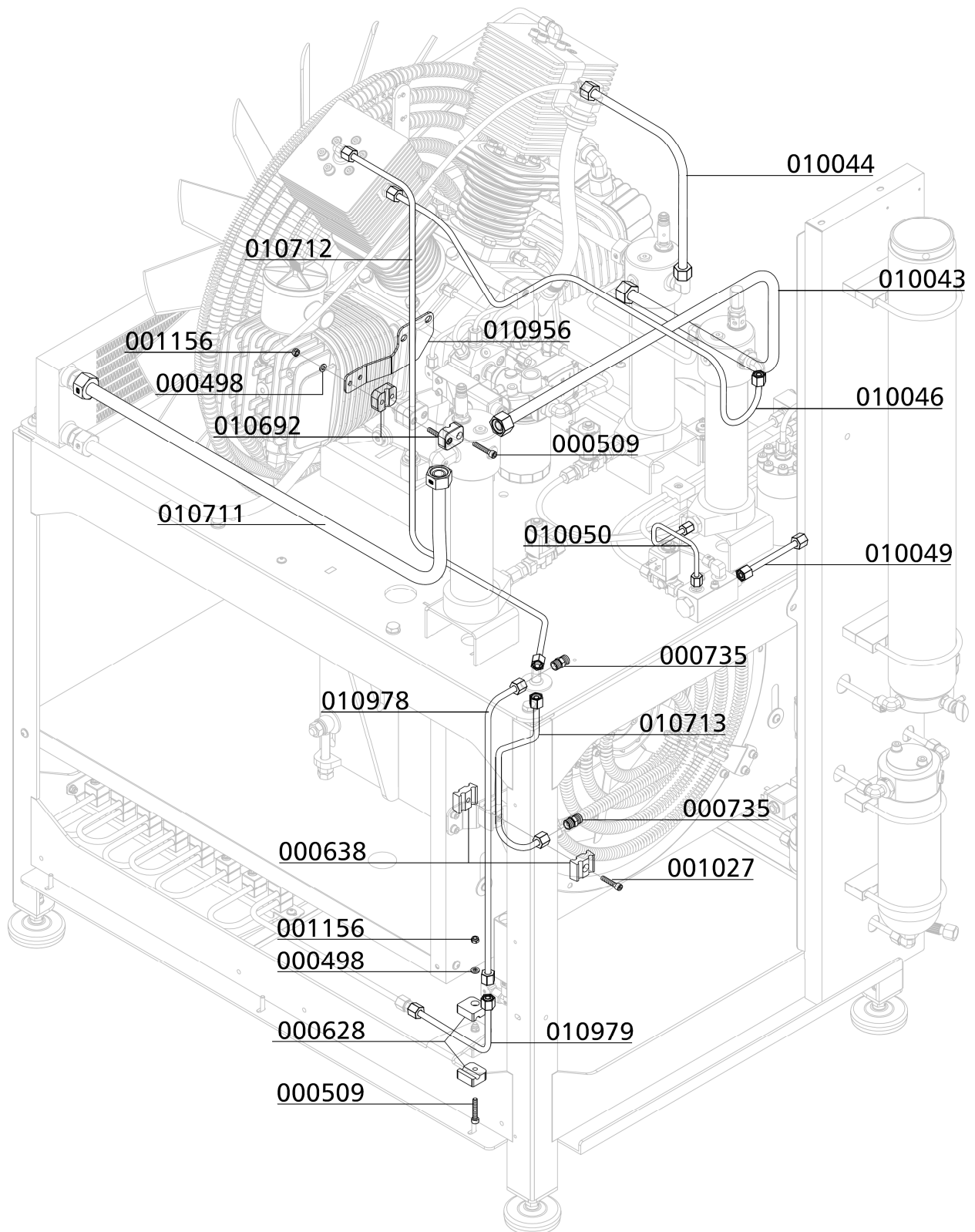

C

**DETAILANSICHT / DETAILED VIEW**

**Rohrleitungssystem / Pipework**

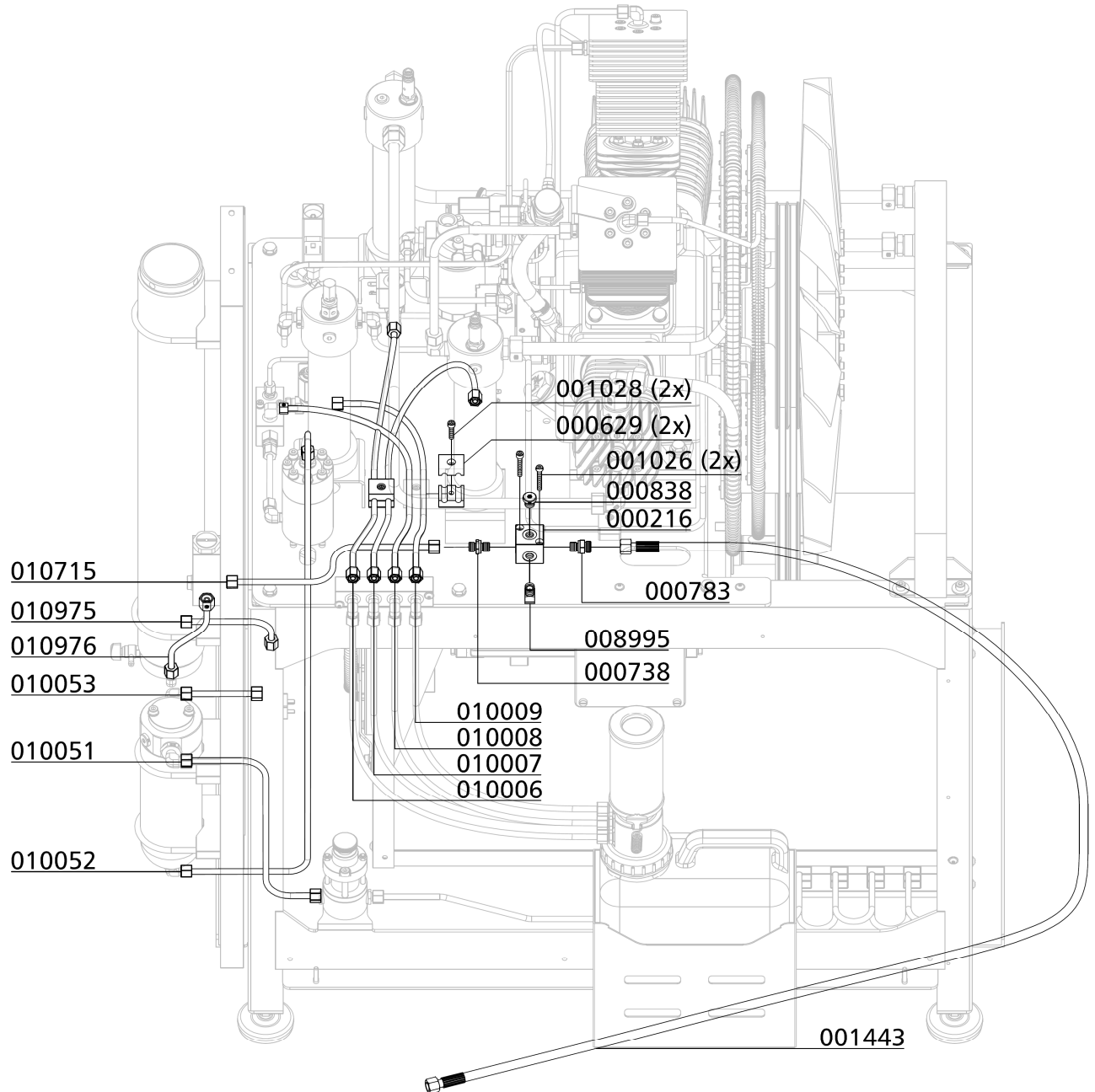



## ERSATZTEILLISTE / SPARE PART LIST

### Baugruppe: Kompressorblock / Assembly: Compressor Block

Best.-Nr. / Order No.	Benennung	Description
000209	Öleinfüllstopfen	Oil Filler Plug
000254	Ventildichtung obere für Ventil 2. Stufe	Upper Valve Gasket, Paper, 2nd
000270	Ventilkopf für Ventil, 2. Stufe	Valve Head for Valve 2nd Stage
000343	Zylinder 3. Stufe	Cylinder 3rd Stage LW 570
000344	Führungszylinder mit 6x Gewindestift	Guide Cylinder c/w 6x setscrew
000346	Zylinder 4. Stufe	Cylinder 4th Stage
000349	Obere Ventildichtung	Upper Valve Gasket
000350	Untere Ventildichtung für Ventil 1.Stufe	Lower Valve Gasket, 1st Stage
000351	Zylinder 1. Stufe	Cylinder 1st Stage
000409	O-Ring Zylinderflansch 1. Stufe	O-Ring - 1st Stage
000414	Distanzhülse Kühlerhalter	Spacer Cooling Bracket s/s
000498	U-Scheibe A6	Washer A6
000628	Einfachschele 1 x 8mm 1 Paar	Pipe Clamp 1x8mm 1pair PVC
000710	Verschraubung	Connection w/o nut& olive seal
000738	Gerade Verschraubung	Straight Connection
000761	Winkelverschraubung	Elbow Connection
000817	Verschraubung	Connection
000820	Verschraubung	Elbow-Connection
000837	Verschlussstopfen	Plug
000838	Verschlussstopfen	Plug
000839	Verschlussstopfen	Plug
000866	Verschraubung	Connection
000867	Winkelverschraubung	Elbow Connect. with fixed nut
000919	Reduzierung	Reducer
000952	6-kant Schraube	Hexagon Bolt
000961	Stiftschraube	Threaded Stud
001027	Zylinderschraube	Allen Bolt
001029	Zylinderschraube	Allen Bolt
001041	Zylinderschraube	Allen Screw
001047	Zylinderschraube	Allen Bolt

C



## ERSATZTEILLISTE / SPARE PART LIST

### Baugruppe: Kompressorblock / Assembly: Compressor Block

Best.-Nr. / Order No.	Benennung	Description
001056	Zylinderschraube	Allen Bolt
001058	Zylinderschraube	Allen Bolt
001060	Zylinderschraube	Allen Bolt
001092	Zylinderschraube	Hexagon Bolt
001100	6-kant Schraube	Hexagon Screw
001101	6-kant Schraube	Hexagon Screw
001156	Stopfmutter	Lock Nut M6
001158	Mutter	Nut M8
001178	U-Scheibe A6	Washer A6
001181	U-Scheibe A8	Washer A8
001186	U-Scheibe A10	Washer A10
001274	O-Ring	O-Ring
001323	CU-Ring	Copper Seal Ring
001449	Verschraubung,	Connection, straight
001635	Dichtring für Öleinfüllstopfen G1"	Rubber Gasket Oil Filler Plug
001766	O-Ring, Lagerdeckel	O-Ring Bearing Cover
002153	Ölablassschlauch inkl. Kugelhahn	Oil drain hose c/w ball valve
002362	Winkeleinschraubverschraubung 6 mm	Elbow Hose Connection 6 mm
002367	Ventilkopf	Valve Head
002932	Distanzbolzen mit M6 Gewinde	Spacer
003189	Schlauchschele Entlüftungsschlauch	Hose clamp
003191	Öleinfüllstopfen LW 450	Oil Filler Plug c/w gasket
003286	Ölschauglas	Oil Level Indicator c/w gasket
003492	Untere Ventildichtung, 2. Stufe	Lower valve gasket, 2nd stage
004749	PG Schlauchdurchführung	PG29 Fitting PVC
005355	Reduziernippel G1/8"IG - G1/8"AG Messing	Reducer Nipple G1/8"-G1/8"
005859	Gerade Einschraubverschraubung 6 mm	Straight Hose Connection 6 mm
006232	Distanzhülse für Kühler	Spacer Sleeve
006417	Ölablassschlauch	Oil drain hose
006856	Zylinder 2. Stufe	Cylinder Ø50 mm, 2nd Stage



## ERSATZTEILLISTE / SPARE PART LIST

### Baugruppe: Kompressorblock / Assembly: Compressor Block

Best.-Nr. / Order No.	Benennung	Description
008850	Wellendichtringdeckel	Shaft Seal Cover
008850	Wellendichtringdeckel	Shaft Seal Cover
008873	Wellendichtring NBR RX	Shaft Seal NBR RX
008874	O-Ring	O-Ring
008877	O-Ring	O-Ring
009053	Lagerdeckel GG25	Main Bearing Flange
009136	Kurbelgehäuse	Crankcase
009444	Ölschlauchstutzen	Oil hose connector
009601	U-Scheibe	Washer
009650	Ventilkopf 1. Stufe	Valve Head, 1st Stage
009686	Halteblech-Ölschlauch	Bracket Oil Hose
009687	Halteblech-Ölschlauch	Bracket Oil Hose
009694	Öleinfüllschlauch Ø18mm	Oil filler hose Ø18mm
009695	Öleinfüllschlauch Ø18mm	Oil filler hose Ø18mm
009772	Halter Öl-Ablassschlauch	Holder Oil drain hose
009838	Befestigungsblech Rohr Ø8mm	Holder Pipe Ø8mm
009853	Gewindestange M6x229mm	Threaded bar
009969	Entlüftungsschlauch Kurbelgehäuse	Crankcase Breather Hose
010640	Gerade Verschraubung	Connection GE 18L - 1"

C





## ERSATZTEILLISTE / SPARE PART LIST

### Kurbelwelle / Crankshaft

Best.-Nr. / Order No.	Benennung	Description
000247	Anlaufscheibe Kurbelwelle, mit Innenfase	Thrust Washer chamfered Vers.
000410	Pleuel	Conrod, 2.,3. & 4. Stage
000411	Pleuel	Conrod 1st Stage
001041	Zylinderschraube	Allen Screw
001087	Zylinderschraube	Hexagon Bolt
001184	Schnorr-Scheibe	Clamp Washer S8
001189	Schnorr-Scheibe S10	Clamp Washer S10
001207	Passfeder (Kurbelwelle LW 300/450)	Woodruff Key
001346	Sicherungsring	Circlip A40
001350	Sicherungsring	Circlip A65
003281	Nadellager Pleuel Ø28xØ22x20 mm	Needle bearing, con-rod
004809	Ölpumpenmitnehmerschraube	Drive bolt
008848	Ölschleuderring	Oil Ring
008849	Ölrohr	Oil Pipe
008852	Anlaufscheibe Kurbelwelle	Thrust Washer
008876	Verschlussschraube	Plug Screw
009004	Kurbelwellenlager (Schwungradseite)	Main Roller Bearing
009005	Kurbelwellenlager (Ölpumpenseite)	Main Roller Bearing
009049	Spezialwerkzeug Pleuellager	Special Tool, removal bearing
009134	Kurbelwelle, komplett; ab 19.10.16	Crankshaft c/w Counter Weight
009970	Pleuel 2., 3. & 4.Stufe	Conrod, 2.,3. & 4. Stage

C



**DETAILANSICHT / DETAILED VIEW**

**Kurbelwelle / Crankshaft**

Spezialwerkzeug Lager Austausch /  
Special Tool Bearing replace  
009049

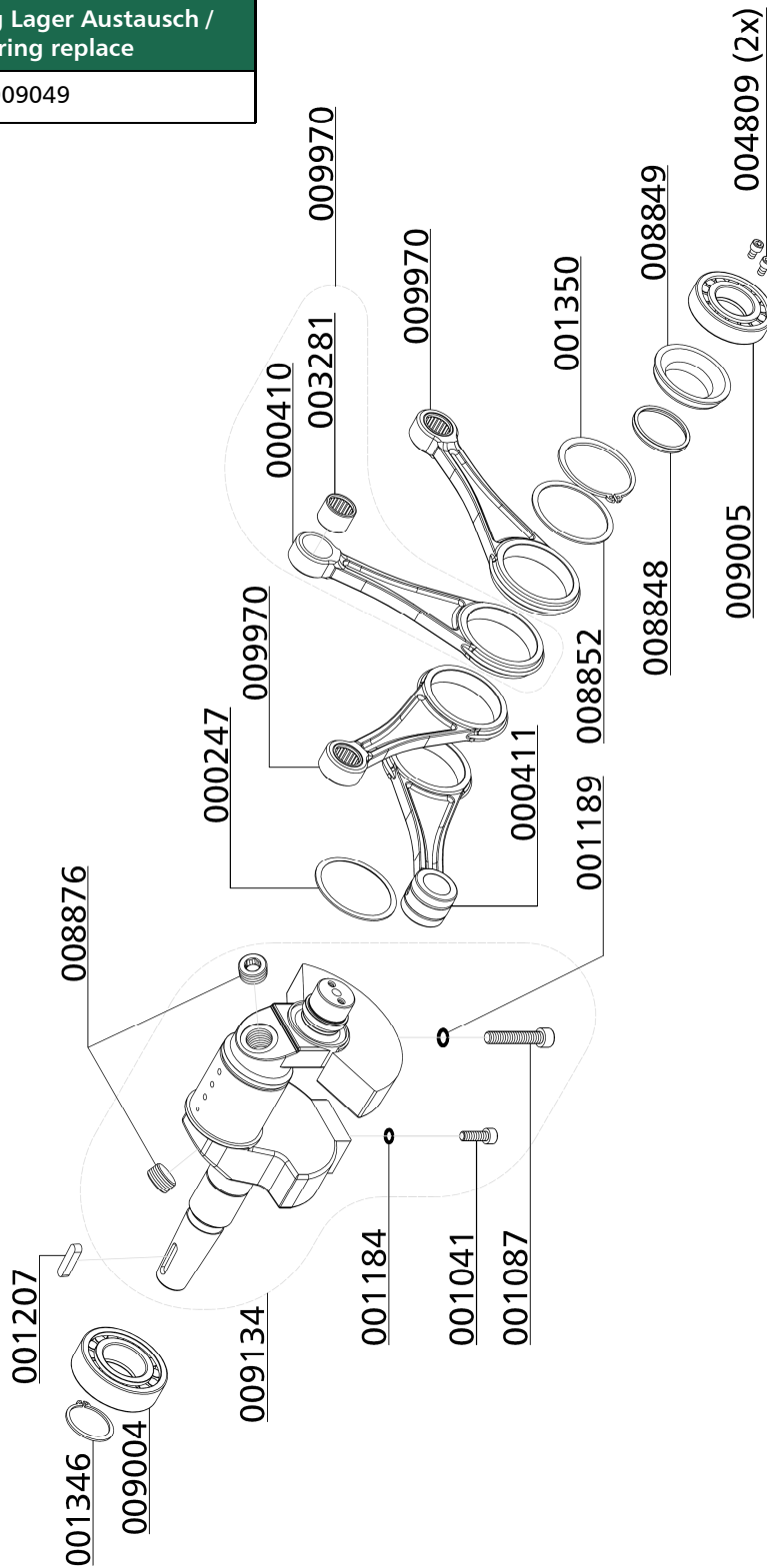



## ERSATZTEILLISTE / SPARE PART LIST

---

### Kolben 1. Stufe / Piston 1st Stage

Best.-Nr. / Order No.	Benennung	Description
000359	Kolben, 1. Stufe, Ø105mm	Piston 1st Stage Ø105 mm
000360	Kolbenringsatz 1. Stufe Ø105mm	Set Piston Rings 1st Stage Ø105mm
000361	Kolbenbolzen, 1. Stufe Ø25x90 mm	Piston Pin Ø25x90mm
001358	Sicherungsring I 25 DIN472	Circlip I 25 DIN472
005454	Spezialwerkzeug, Spannband	Special Tool, tightening strap

C

## DETAILANSICHT / DETAILED VIEW

### Kolben 1. Stufe / Piston 1st Stage

Spezialwerkzeug Kolbenmontage / Special Tool Piston fitting	Spezialwerkzeug Kolbenringmontage / Pistonring fitting Tool
005454	-

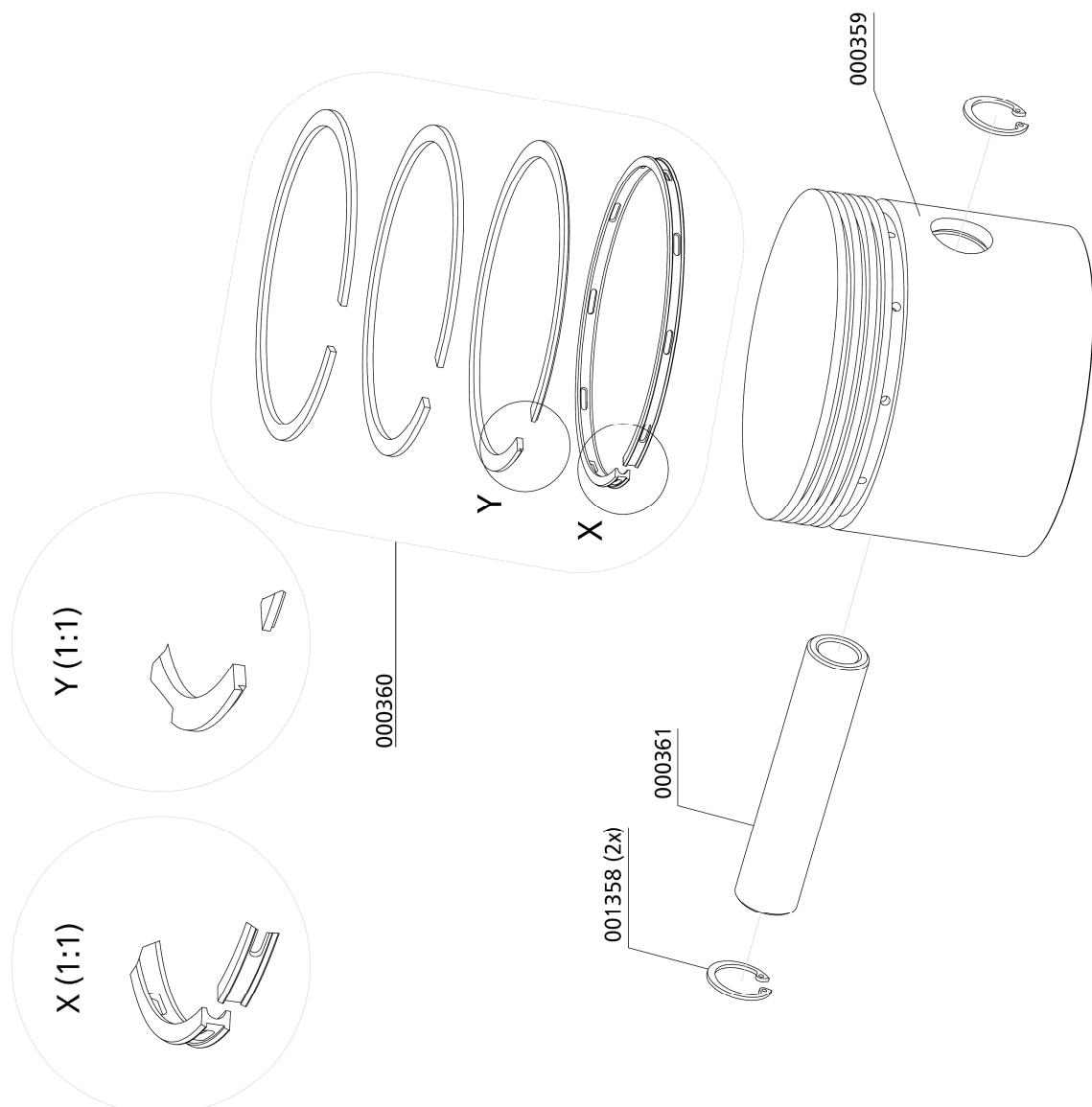

C



## ERSATZTEILLISTE / SPARE PART LIST

---

### Kolben 2. Stufe / Piston 2nd Stage

Best.-Nr. / Order No.	Benennung	Description
000362	Kolben, 2. Stufe	Piston 2nd Stage
000363	Kolbenringsatz 2. Stufe, Ø50mm	Set Piston Rings 2nd Stage Ø50mm
000373	Kolbenbolzen, 2. / 3. / 4. Stufe	Piston Pin, 2nd Stage
001356	Sicherungsring, I 22 DIN472	Circlip I22 DIN472
009397	Spezialwerkzeug Kolbenmontage Ø50mm	Special Tool, Splitted bush

C

**DETAILANSICHT / DETAILED VIEW**

**Kolben 2. Stufe / Piston 2nd Stage**

Spezialwerkzeug Kolbenmontage / Special Tool Piston fitting	Spezialwerkzeug Kolbenringmontage / Pistonring fitting Tool
009397	-

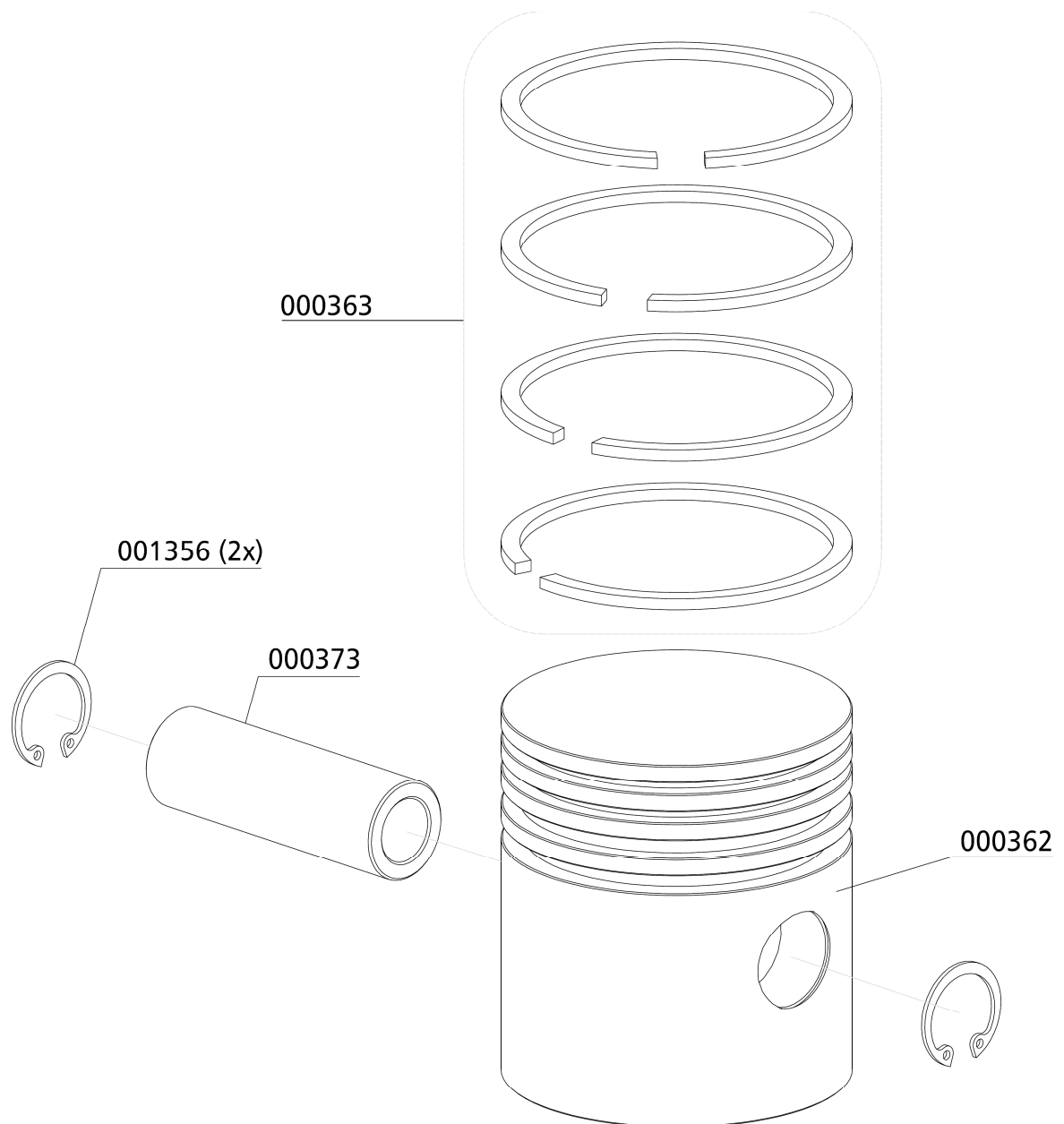

C



## ERSATZTEILLISTE / SPARE PART LIST

### Kolben 3. Stufe / Piston 3rd Stage

Best.-Nr. / Order No.	Benennung	Description
000365	Kolbenringsatz Ø25mm	Set Piston Rings Ø25mm
000366	Kolben Ø25mm/50mm, 3. Stufe	Piston Ø25mm/50mm, 3rd Stage
000373	Kolbenbolzen Ø22 x 40mm	Piston Pin Ø22 x 40mm
001356	Sicherungsring, I 22 DIN472	Circlip I22 DIN472
005461	Spezialwerkzeug, Halbschalen, Ø22mm	Special Tool, Splitted bush
008325	Kolben Ø25/50, komplett	Piston Ø25/50, complete
008735	Spezialwerkzeug Kolbenringe, 2-teilig Ø25 mm Montagezange & Hülse	Special Tool Piston Rings Ø25

C

**DETAILANSICHT / DETAILED VIEW**

**Kolben 3. Stufe / Piston 3rd Stage**

Spezialwerkzeug Kolbenmontage / Special Tool Piston fitting	Spezialwerkzeug Kolbenringmontage / Pistonring fitting Tool
005461	008735

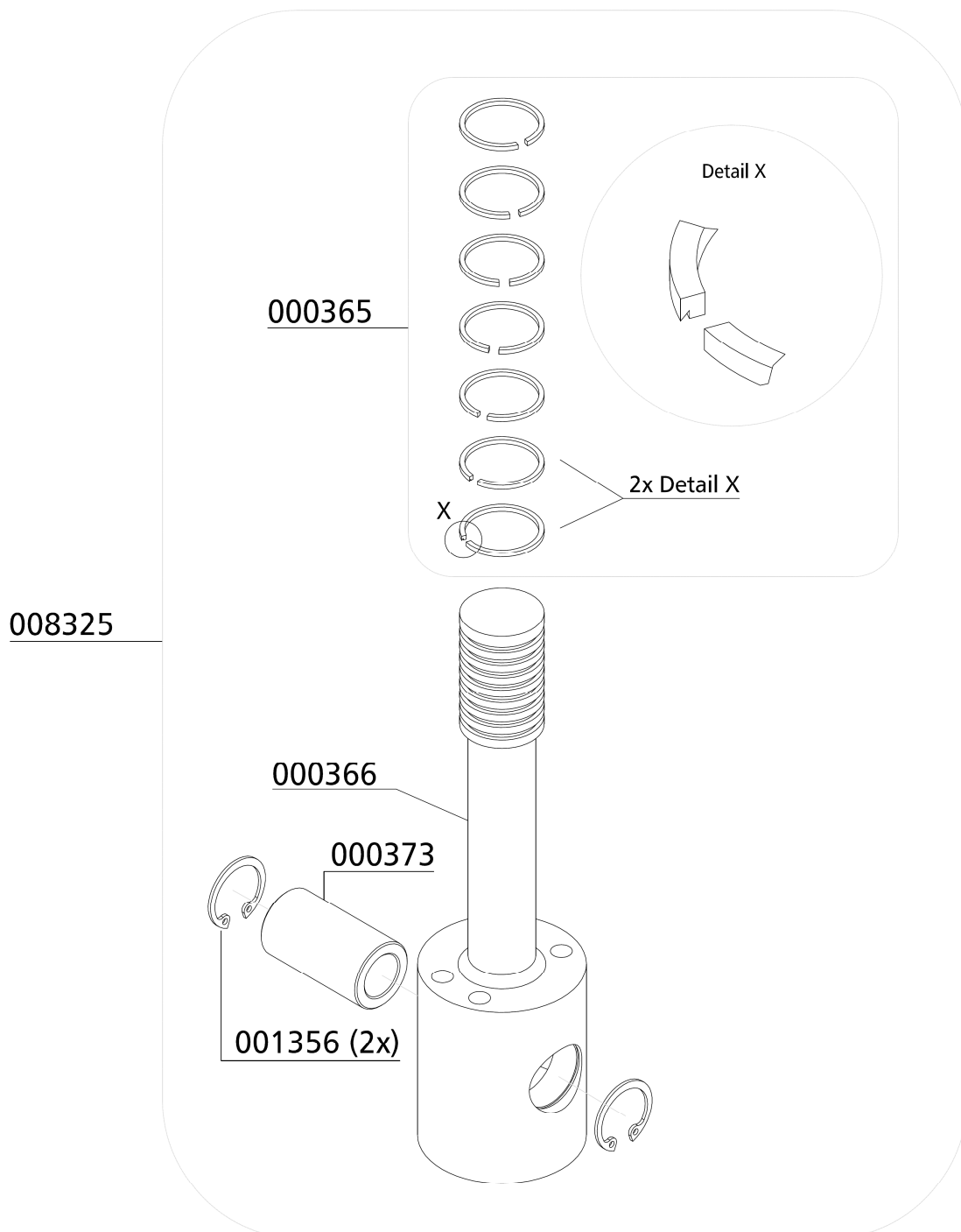

C



## ERSATZTEILLISTE / SPARE PART LIST

---

### Kolben 4. Stufe / Piston 4th Stage

Best.-Nr. / Order No.	Benennung	Description
000367	Kolbenringsatz Ø14mm	Set Piston Rings Ø14mm
000368	Kolben Ø14mm/50mm, komplett	Piston Ø14mm/50mm, complete
000373	Kolbenbolzen Ø22 x 40 mm	Piston Pin Ø22 x 40 mm
001356	Sicherungsring I 22 DIN472	Circlip I 22 DIN472
005458	Spezialwerkzeug, 2 Halbschalen für Montage Kolben Ø14mm	Special Tool, Splitted bush
005459	Spezialwerkzeug, Montagehülse für Montage Kolbenringe Ø 14mm	Special Tool, Fitting tool
005460	Spezialwerkzeug, Montagezange für Montage Kolbenringe Ø 14mm	Special Tool, Pliers
007432	Kolben Ø14mm/50mm	Piston Ø14mm/50mm

C



## DETAILANSICHT / DETAILED VIEW

### Kolben 4. Stufe / Piston 4th Stage

Spezialwerkzeug Kolbenmontage / Special Tool Piston fitting	Spezialwerkzeug Kolbenringmontage / Pistonring fitting Tool
005458	005459 / 005460

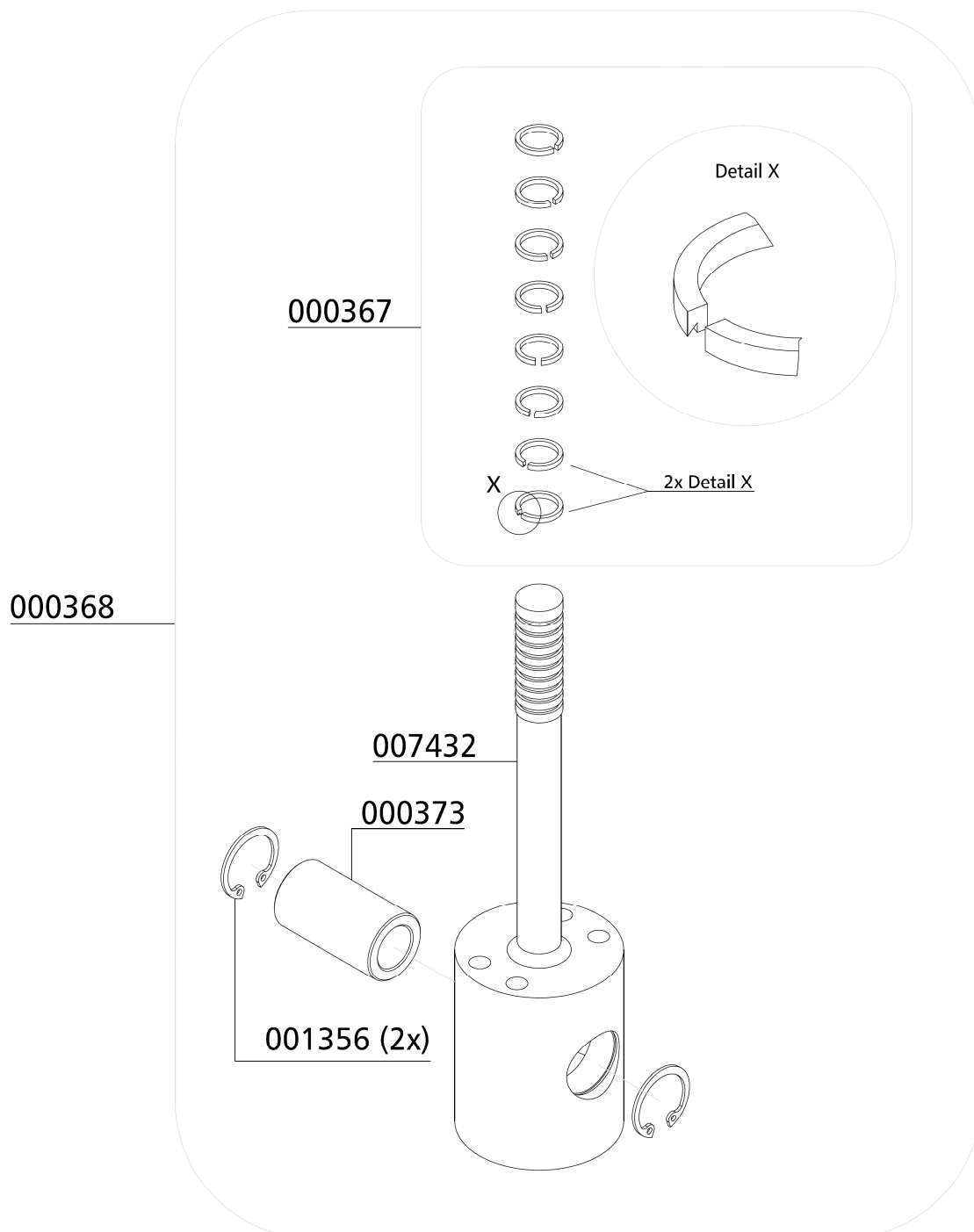

C



## ERSATZTEILLISTE / SPARE PART LIST

---

### Ventil 1. & 2. Stufe / Valve 1st & 2nd Stage

Best.-Nr. / Order No.	Benennung	Description
000256	Saug- Druckventil, 2. Stufe	In-&Outlet Valve, 2nd Stage
000369	Saug- Druckventil, 1. Stufe	In-&Outlet Valve, 1st Stage

C

**DETAILANSICHT / DETAILED VIEW**

---

**Ventil 1. & 2. Stufe / Valve 1st & 2nd Stage**

000256  
Ventil 2.Stufe  
Valve 2nd Stage

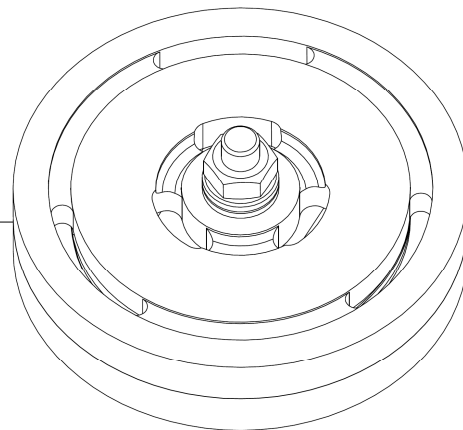

000369  
Ventil 1.Stufe  
Valve 1st Stage

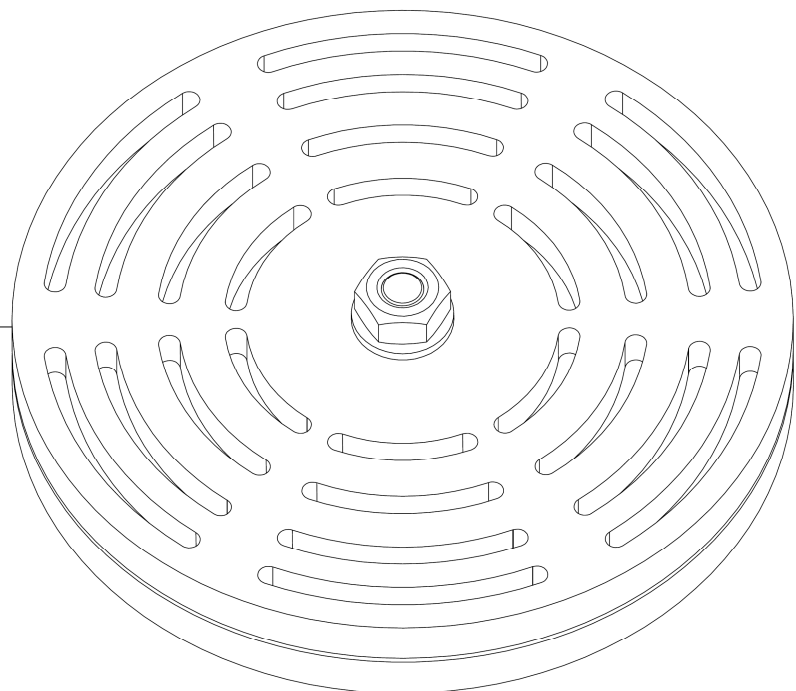

C



## ERSATZTEILLISTE / SPARE PART LIST

---

### Baugruppe: Ventil 3. Stufe / Assembly: Valve 3rd Stage

Best.-Nr. / Order No.	Benennung	Description
000533	Ventildichtung, Saug-& Druckventil unten	Lower Valve Gasket, 3rd Stage
000540	Dichtring / Dichtung, 3. Stufe	Upper Alloy Seal Ring, 3rd Stage
010346	Saug-Druckventil, 3. Stufe, komplett	In- & Outlet Valve, 3rd Stage

C

**DETAILANSICHT / DETAILED VIEW**

**Baugruppe: Ventil 3. Stufe / Assembly: Valve 3rd Stage**

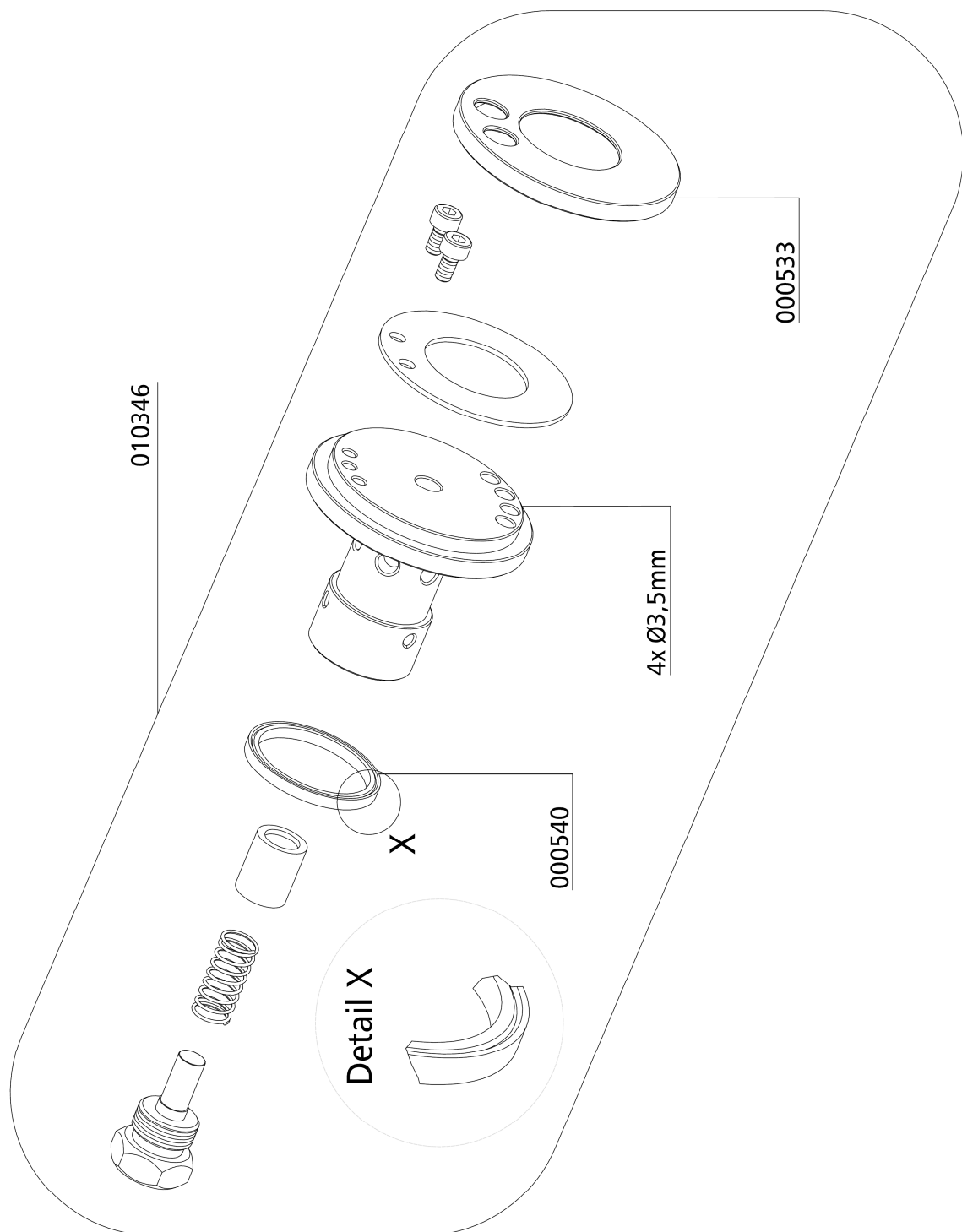

C



## ERSATZTEILLISTE / SPARE PART LIST

---

### Ventil 4. Stufe / Valve 4th Stage

Best.-Nr. / Order No.	Benennung	Description
000534	Ventildichtung, Saug- & Druckventil, Typ 44/15/36-0,3, Al	Lower Valve Gasket, Type 44/15/36-0,3, Alloy
000540	Dichtring, Saug- u. Druckventil oben, Al	Upper Alloy Seal Ring, Alloy
010347	Saug-Druckventil, 4. Stufe, komplett	In- & Outlet Valve, 4th Stage

C

**DETAILANSICHT / DETAILED VIEW**

**Ventil 4. Stufe / Valve 4th Stage**

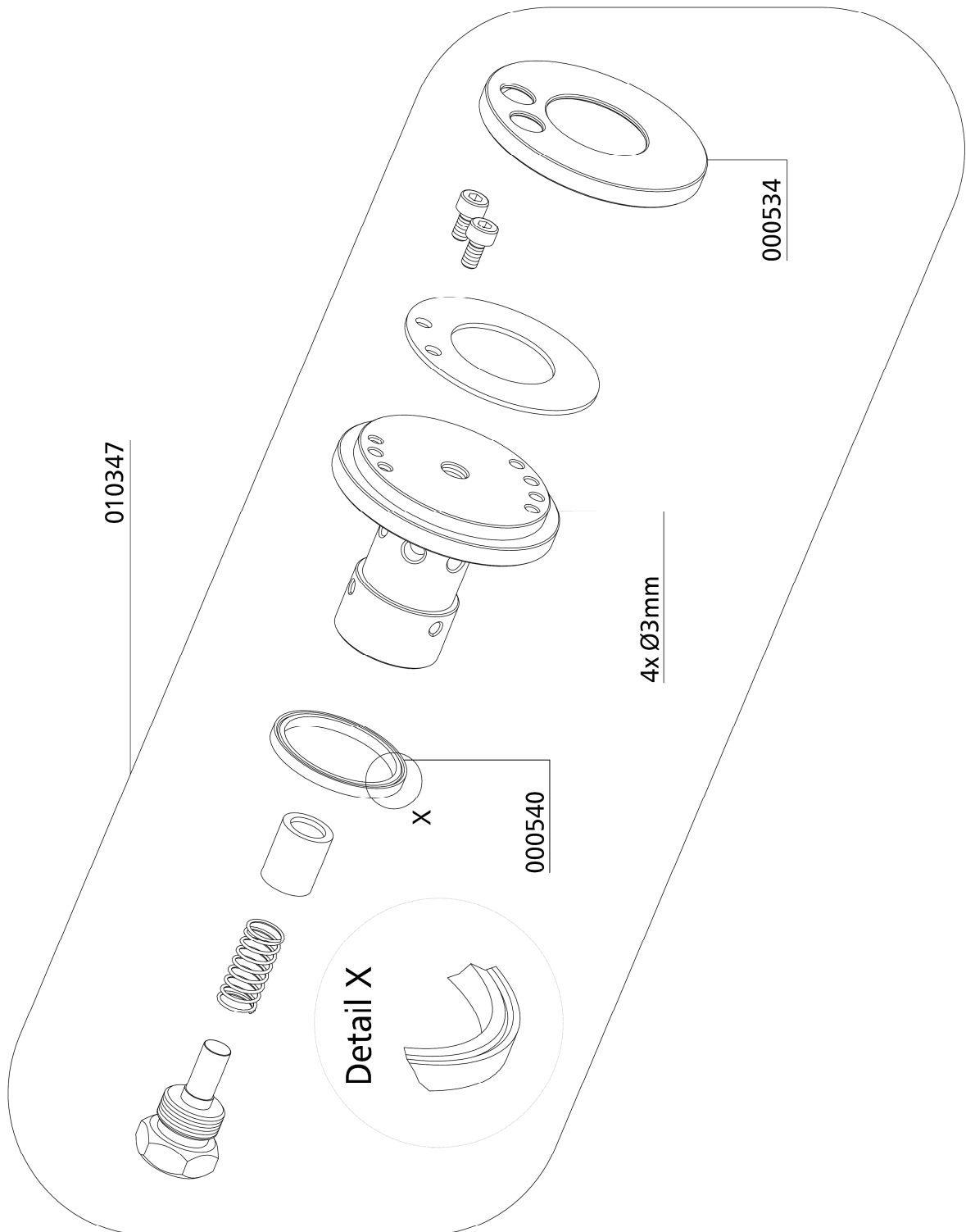

C



## ERSATZTEILLISTE / SPARE PART LIST

### Kühler 1. Stufe / Cooler 1st Stage

Best.-Nr. / Order No.	Benennung	Description
000498	U-Scheibe A6	Washer A6
000866	Verschraubung	Connection
001030	Zylinderschraube	Allen Bolt
001041	Zylinderschraube	Allen Screw
001047	Zylinderschraube	Allen Bolt
001182	U-Scheibe A8	Washer A8
005224	U-Scheibe	Washer A6, 6.4x18x3mm DIN7349
006232	Distanzhülse für Kühler	Spacer Sleeve
008221	Kühler 1. Stufe	Radiator 1st Stage
009551	Kühlerhalterung	Bracket for Cooler
009564	Rohrschelle Ø21 - 12 breit	Pipe Clamp
010394	Kühler 1. Stufe	Cooler 1st Stage LW 700 ES II

C



**DETAILANSICHT / DETAILED VIEW**

**Kühler 1. Stufe / Cooler 1st Stage**

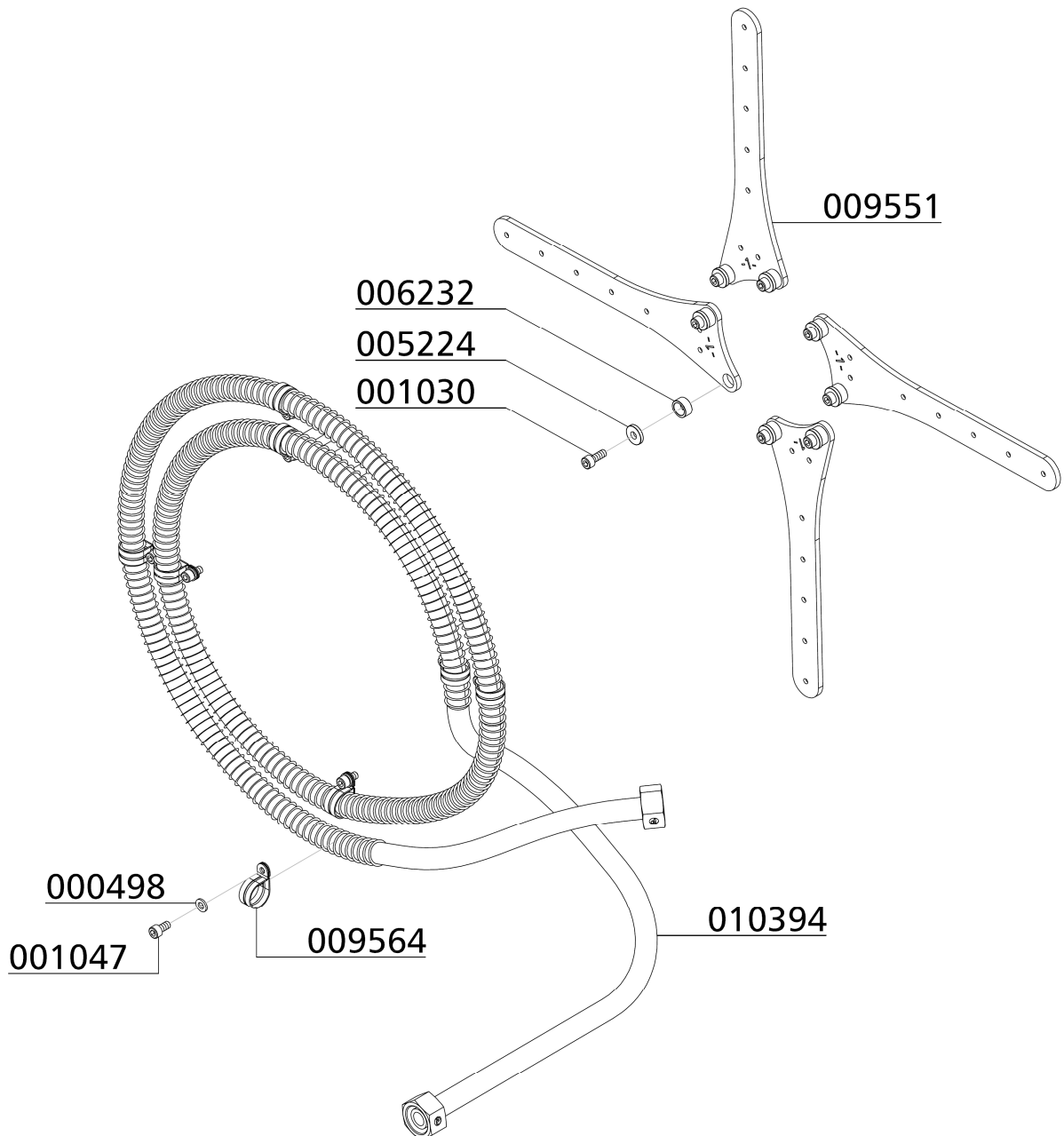

C

**DETAILANSICHT / DETAILED VIEW**

**Kühler 1. Stufe / Cooler 1st Stage**

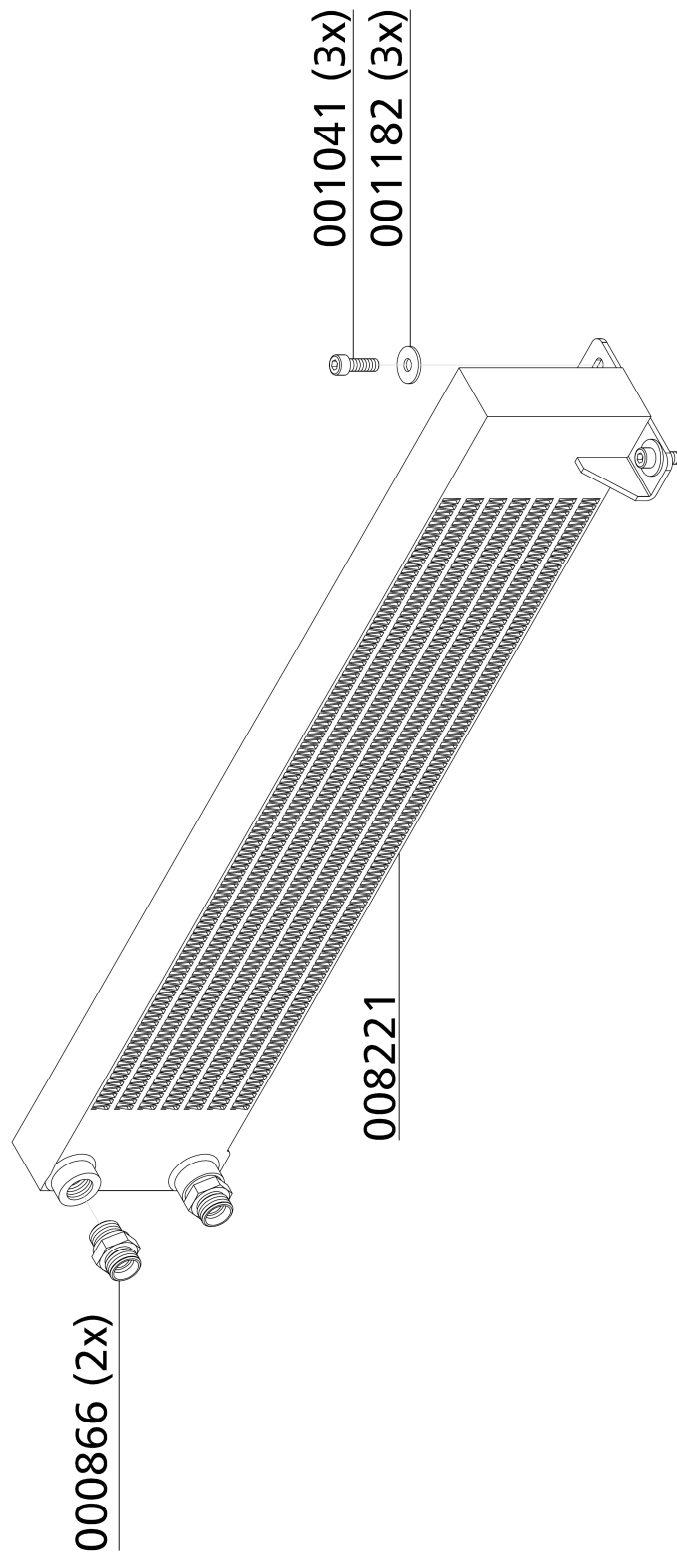

C



## ERSATZTEILLISTE / SPARE PART LIST

---

### Kühler 2. Stufe / Cooler 2nd Stage

Best.-Nr. / Order No.	Benennung	Description
000498	U-Scheibe A6	Washer A6
001047	Zylinderschraube	Allen Bolt
009564	Rohrschelle Ø21 - 12 breit	Pipe Clamp
010395	Kühler 2. Stufe	Cooler 2nd Stage LW 700

C

**DETAILANSICHT / DETAILED VIEW**

---

**Kühler 2. Stufe / Cooler 2nd Stage**

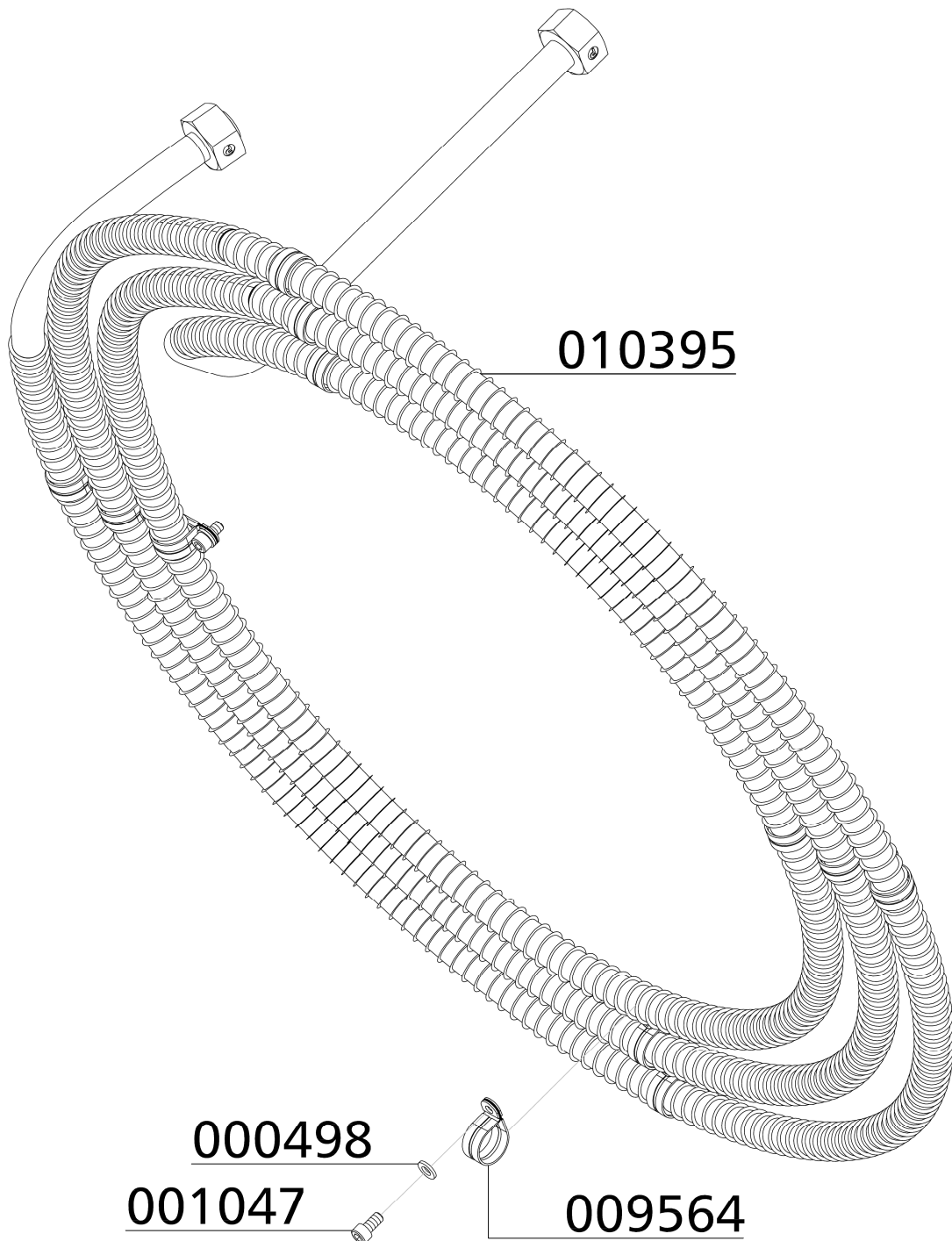

C



## ERSATZTEILLISTE / SPARE PART LIST

---

### Kühler 3. Stufe / Cooler 3rd Stage

Best.-Nr. / Order No.	Benennung	Description
000498	U-Scheibe A6	Washer A6
000628	Einfachschelle 1 x 8mm 1 Paar	Pipe Clamp 1x8mm 1pair PVC
000735	Verschraubung	Connection
001027	Zylinderschraube	Allen Bolt
001047	Zylinderschraube	Allen Bolt
001848	Rohrschelle (Ø15-18mm)	Pipe Clamp, 8mm Finned Pipe
009552	Kühlerhalterung 3. Stufe	Bracket for Cooler
010422	Kühler 3. Stufe, Teil 1	Cooler 3rd Stage LW 700
010423	Kühler 3. Stufe, Teil 2	Cooler 3rd Stage LW 700
010708	Rohrleitung Ø8mm, komplett mit M.&S.	Pipe Ø8mm

C

**DETAILANSICHT / DETAILED VIEW**

**Kühler 3. Stufe / Cooler 3rd Stage**

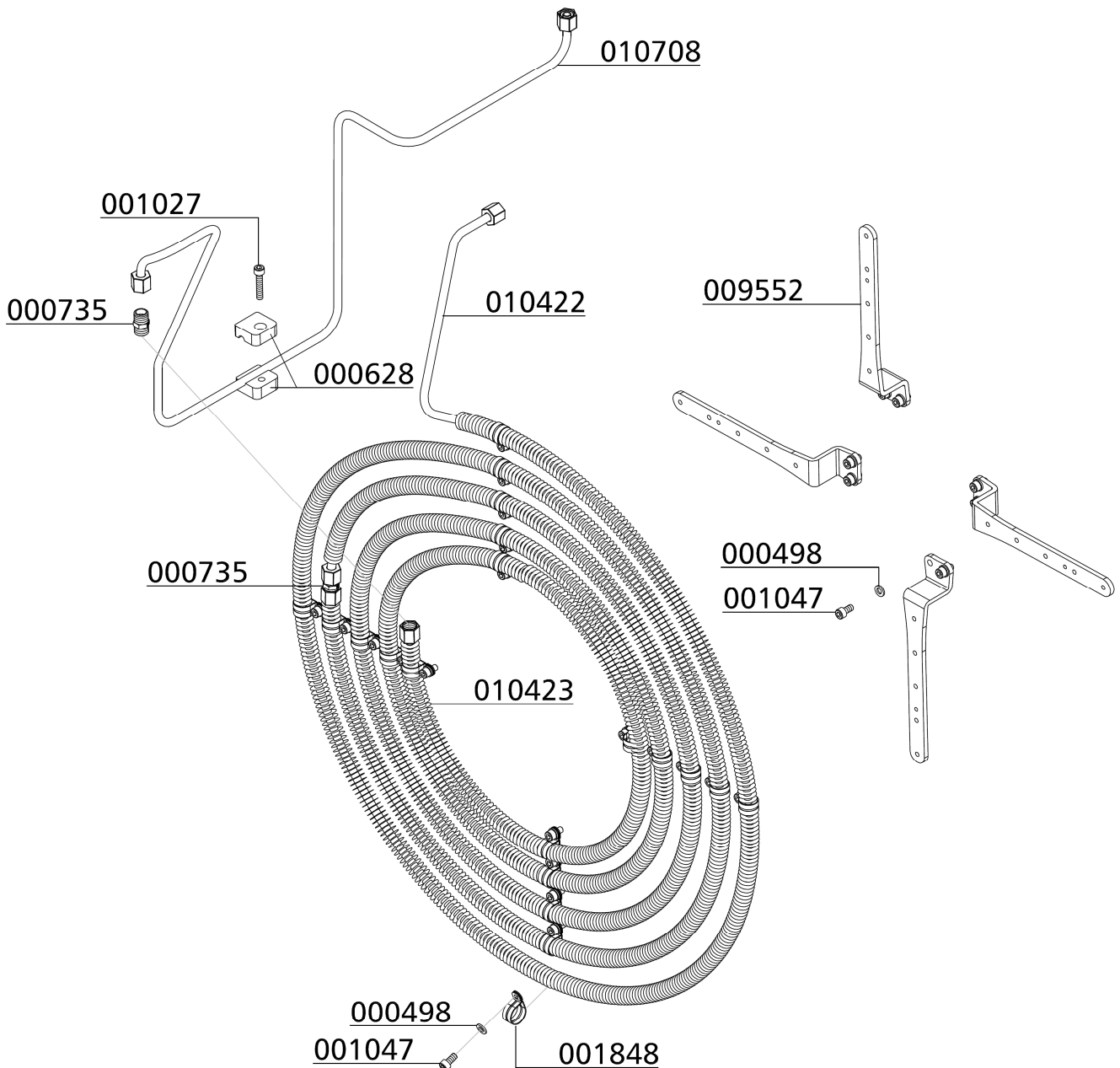

C



## ERSATZTEILLISTE / SPARE PART LIST

### Kühler 4. Stufe / Cooler 4th Stage

Best.-Nr. / Order No.	Benennung	Description
000498	U-Scheibe A6	Washer A6
000628	Einfachschelle 1 x 8mm 1 Paar	Pipe Clamp 1x8mm 1pair PVC
000735	Verschraubung	Connection
000765	Schneidring 8 mm	Olive Seal 8 mm
000766	Überwurfmutter 08 L	Nut
001013	Zylinderschraube	Allen Bolt
001027	Zylinderschraube	Allen Bolt
001029	Zylinderschraube	Allen Bolt
001156	Stoppmutter	Lock Nut M6
001848	Rohrschelle (Ø15-18mm)	Pipe Clamp, 8mm Finned Pipe
005841	Linsenflanschschraube mit	Lens Head Screw
005842	Linsenflanschschraube mit	Lens Head Screw
006400	Zusatzkühler, Endstufe, kompl.	Additional Cooler, Final Stage
006401	Befestigungsblech für Kühlrohrklemmen	Mounting sheet for clamps
006402	Kühlrohr Zusatzkühler	Cooling Pipe Additional Cooler
010424	Kühler 4. Stufe, mit M. & S.	Cooler 4th Stage LW 700
010433	Kühlrohrhalterung -1-	Cooling Pipe Bracket -1-
010434	Kühlrohrhalterung -2-	Cooling Pipe Bracket -2-

C

**DETAILANSICHT / DETAILED VIEW**

**Kühler 4. Stufe / Cooler 4th Stage**

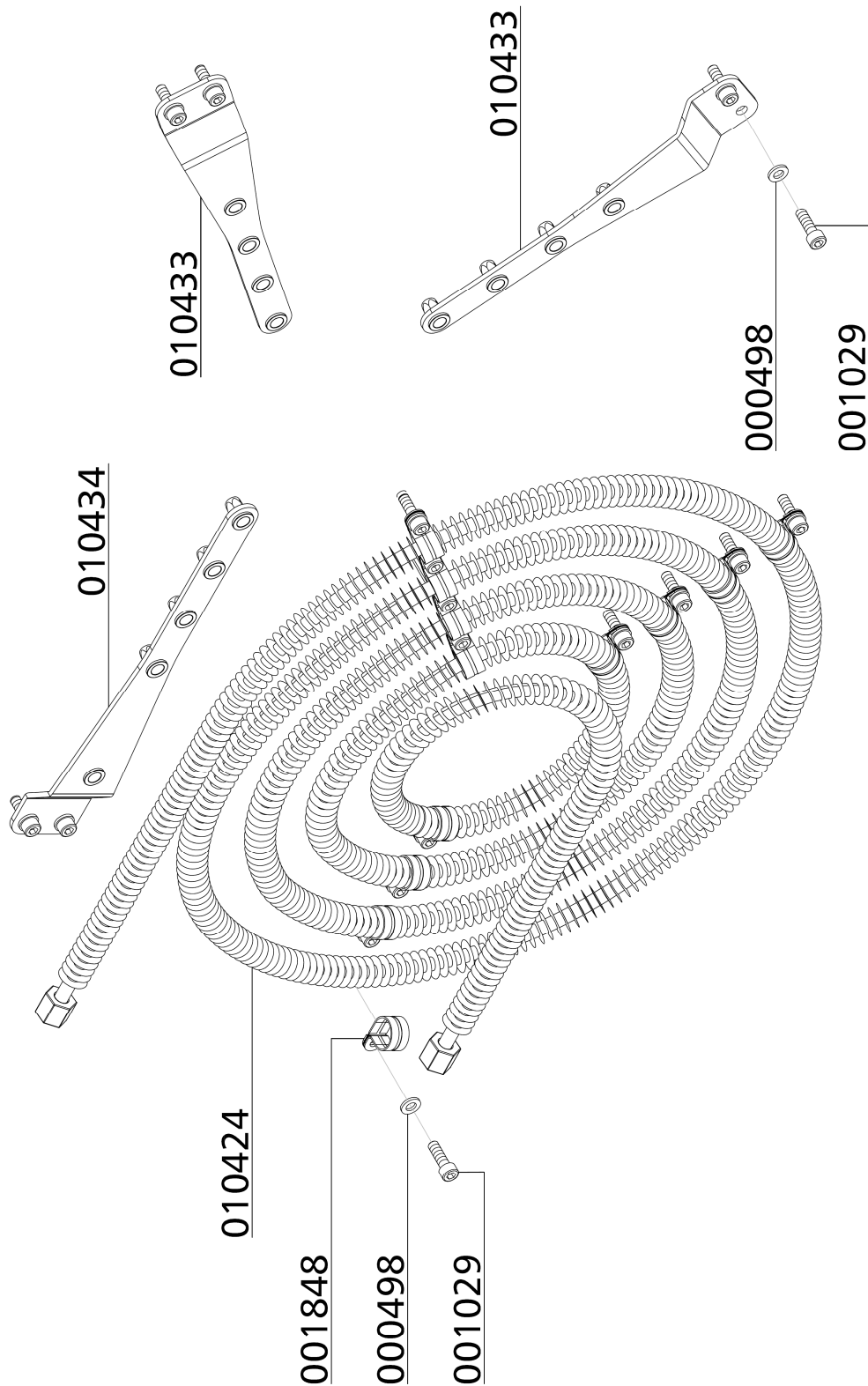



**DETAILANSICHT / DETAILED VIEW**

**Kühler 4. Stufe / Cooler 4th Stage**

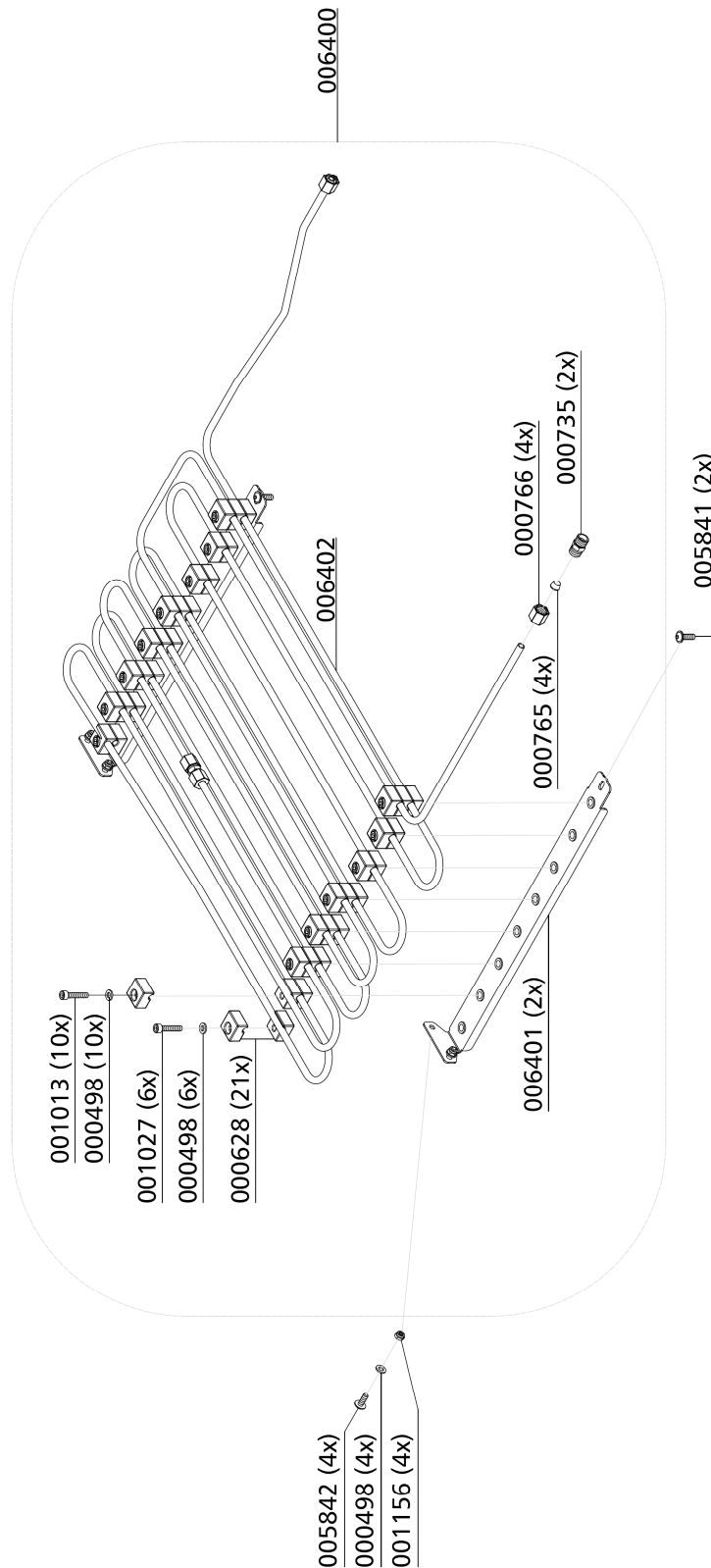

C

**Ölpumpe / Oil Pump**

Best.-Nr. / Order No.	Benennung	Description
000208	Ölpumpenantriebsflansch	Drive Flange Oil Pump
000498	U-Scheibe A6	Washer A6
000710	Verschraubung	Connection w/o nut& olive seal
000712	Verschraubung	Connection w/o nut& olive seal
000759	Verschraubung	Elbow connection c/w nut&olive
000761	Winkelverschraubung	Elbow Connection
000783	Verschraubung	Straight Connection
000838	Verschlussstopfen	Plug
000895	Doppelnippel	Double Nipple
000921	Reduzierung	Reducer
000958	Gewindestift, Madenschraube	Hexagon Socket Screw
001014	Gewindestift mit Zapfen	Hexagon Socket Screw
001027	Zylinderschraube	Allen Bolt
001046	Zylinderschraube	Allen Screw
002340	O-Ring Ölpumpenflansch	O-Ring, oil pump flange
008851	Ölpumpenflansch	Oil Pump Flange
008872	O-Ring	O-Ring
009183	Halter Ölverteilerblock LW 450	Bracket oil distributor block
009242	Öldruckleitung Ø8mm	Oil Suction Pipe
009371	Ölverteilerblock, Alu	Oil distributor block, alloy
009445	Niederdruckfilter	Low-Pressure Filter, 10 bar
009446	Ölfilterwechsepatrone	Oil Filter Cartridge
009498	Öldruckleitung Ø6mm, mit 2mm Düse	Oil Suction Pipe
009501	Öldruckleitung Ø6mm, mit 0,7mm Düse	Oil Pressure Pipe
009502	Öldruckleitung Ø6mm, mit 0,7mm Düse	Oil Pressure Pipe
009545	Ölpumpensieb für Ölpumpe	Sieve Oil Pump
009546	Dichtung Ölpumpendeckel	Gasket Oil Pump Cover
009610	Ölpumpe	Oil Pump
010893	Ölsaugleitung Ø10mm	Oil Suction Pipe

## DETAILANSICHT / DETAILED VIEW

### Ölpumpe / Oil Pump

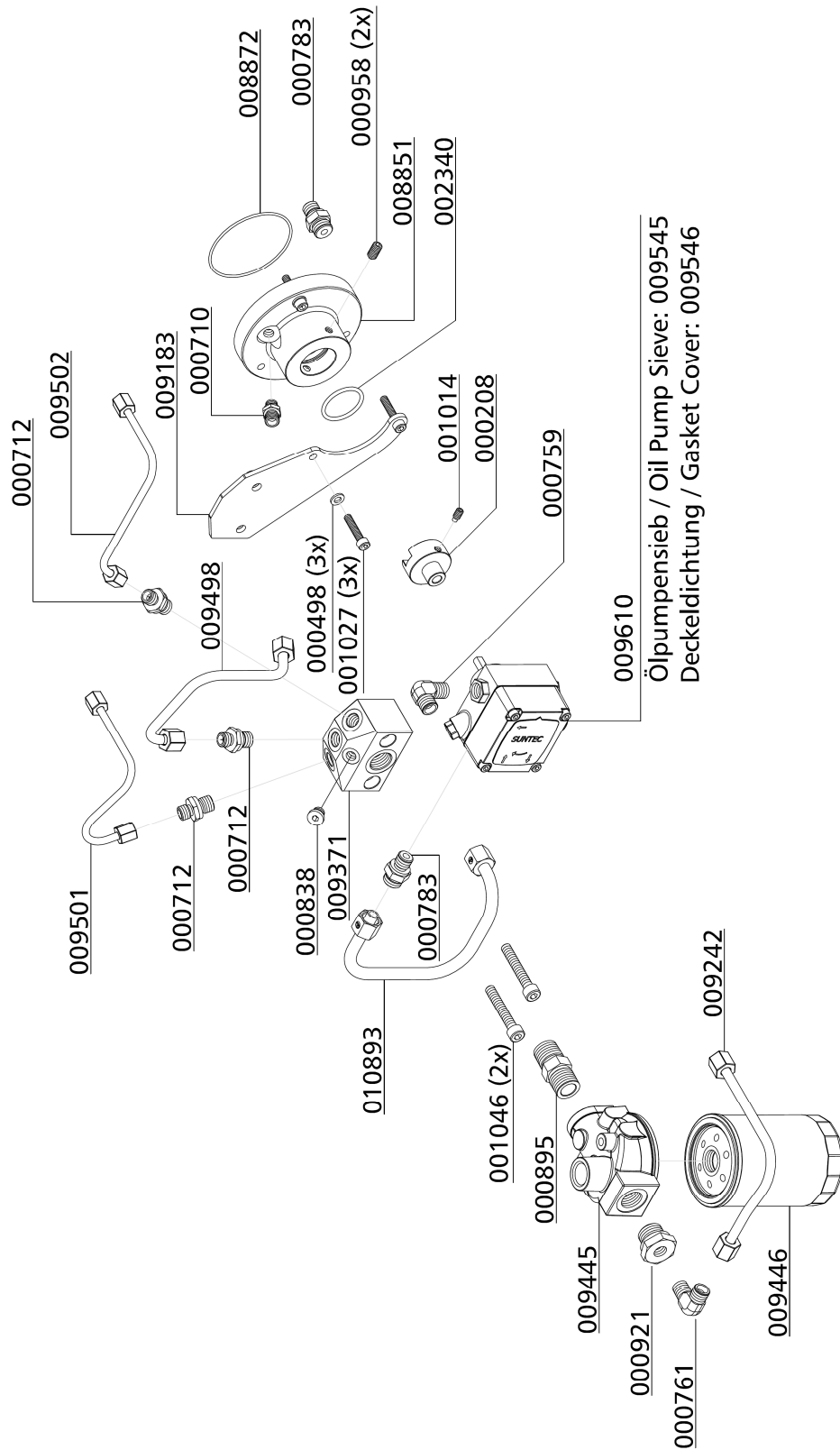



## ERSATZTEILLISTE / SPARE PART LIST

---

### Baugruppe: Ölablassschlauch / Assembly: Oil Drainage Tube

Best.-Nr. / Order No.	Benennung	Description
000817	Verschraubung	Connection
001548	Verschraubung	Connection
008655	Linsenflanschschraube mit Innensechskant M6x12 mm, DIN 7380F, 10.9	Lens Head Screw M6x12 mm, DIN 7380F, 10.9
008670	Ölablassschlauch inkl. Kugelhahn	Oil drain hose c/w ball valve
008671	Ölablassschlauch	Oil drain hose
009772	Halter Öl-Ablausschlauch	Holder Oil drain hose

C

**DETAILANSICHT / DETAILED VIEW**

---

**Baugruppe: Ölablassschlauch / Assembly: Oil Drainage Tube**

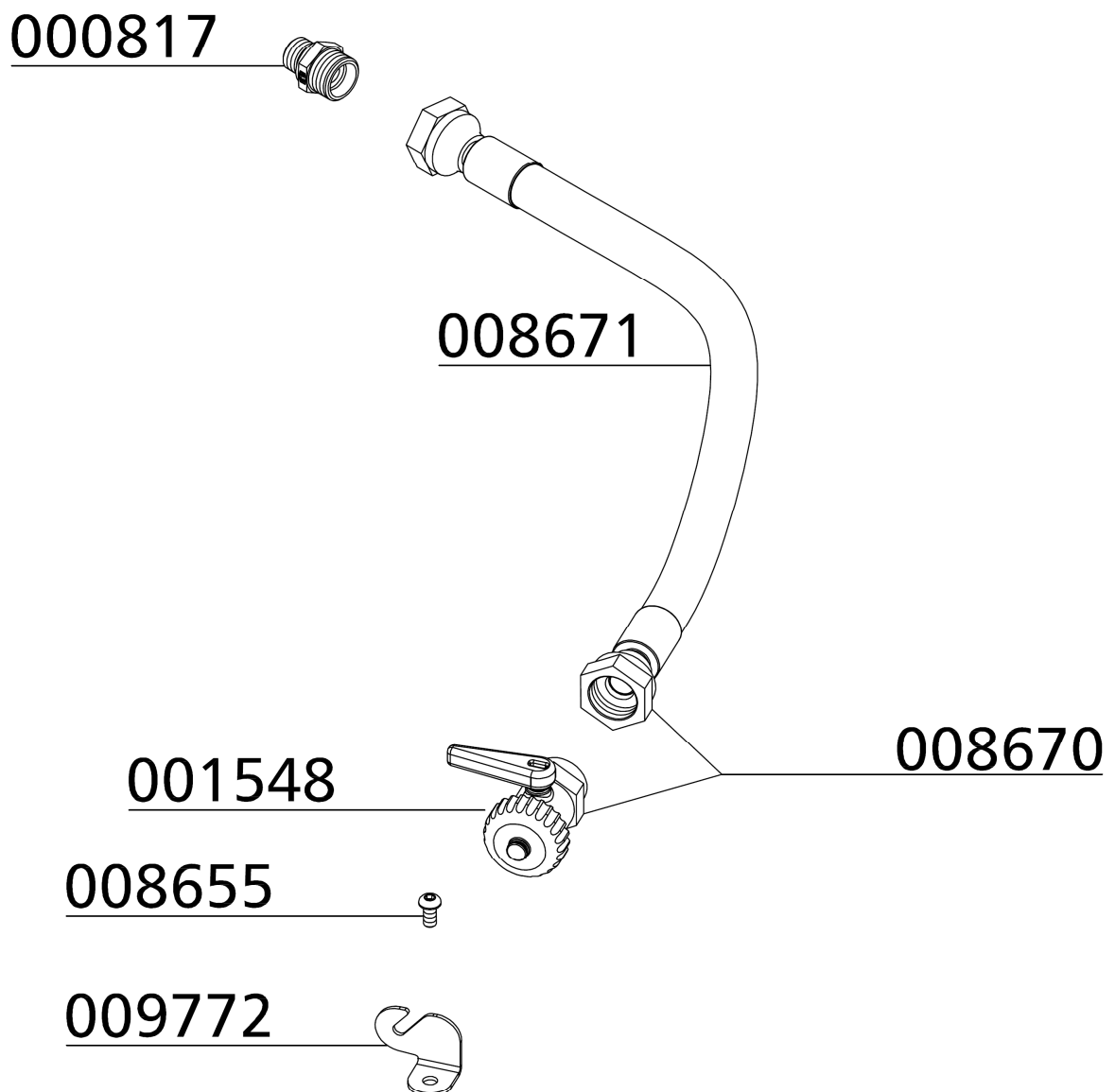

C



## ERSATZTEILLISTE / SPARE PART LIST

---

### Baugruppe: Ansaugfilter / Intake Filter

Best.-Nr. / Order No.	Benennung	Description
000170	Ansaugfilterpatrone	Air Intake Filter Cartridge
001772	Flügelmutter, PVC-schwarz	Winged Nut, PVC black
001782	O-Ring, Ansaugfiltergehäuse	O-Ring, Intake Filter Housing
009652	Gehäuse für Ansaugfilter	Intake Filter Housing
009653	Deckel für Ansaugfilter	Cover Intake filter housing
009658	O-Ring	O-Ring

C

**DETAILANSICHT / DETAILED VIEW**

---

**Baugruppe: Ansaugfilter / Intake Filter**

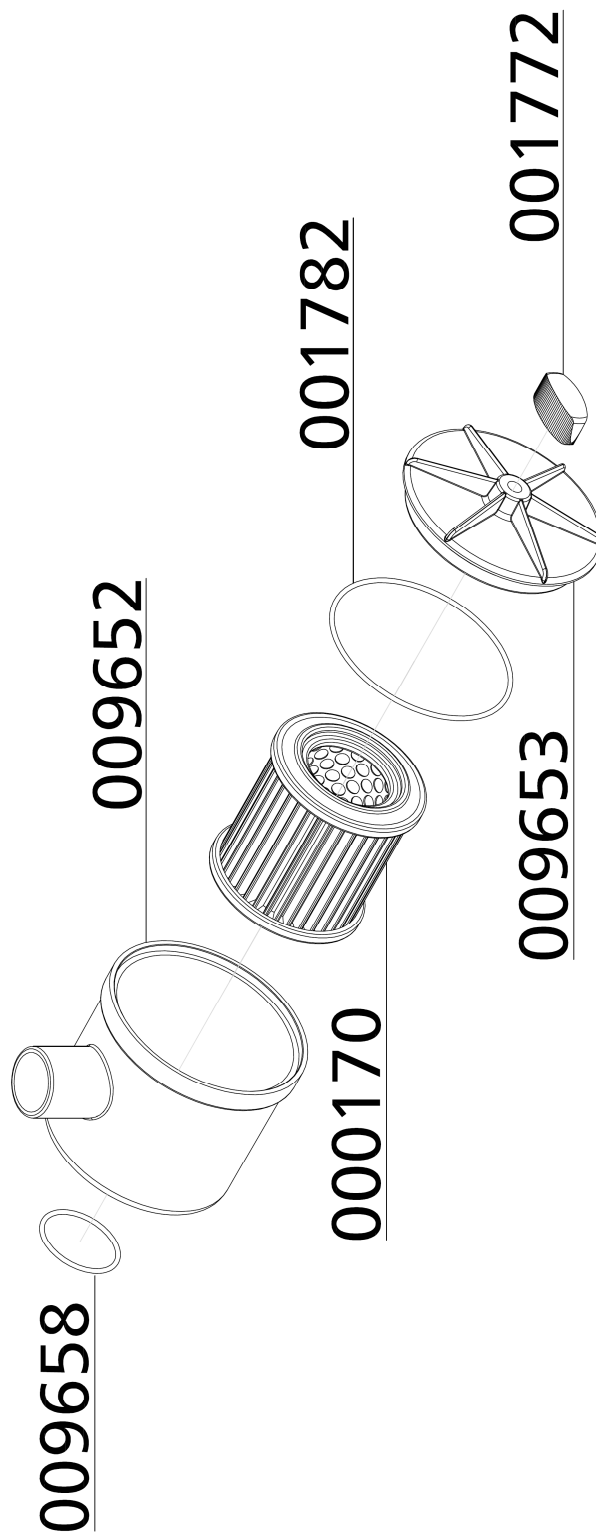

C



## ERSATZTEILLISTE / SPARE PART LIST

---

### Lüfterrad / Cooling Fan

Best.-Nr. / Order No.	Benennung	Description
000318	Zentrierring, Lüfterblätter	Fixing Ring Fan Blades
000498	U-Scheibe A6	Washer A6
001030	Zylinderschraube, M6x16mm DIN912 8.8 ZN	Allen Bolt, M6x16mm DIN912 8.8 ZN
001133	6-kant Schraube	Hexagon Bolt M12x30
002335	Ventilatorflügelblatt, schwarz	Fan Blade, black, new version
005122	U-Scheibe Kurbelwelle	Washer, crank shaft
007181	Schwungscheibe	Flywheel
010168	Zahnscheibe A12	Lock Washer A12

C



**DETAILANSICHT / DETAILED VIEW**

**Lüfterrad / Cooling Fan**

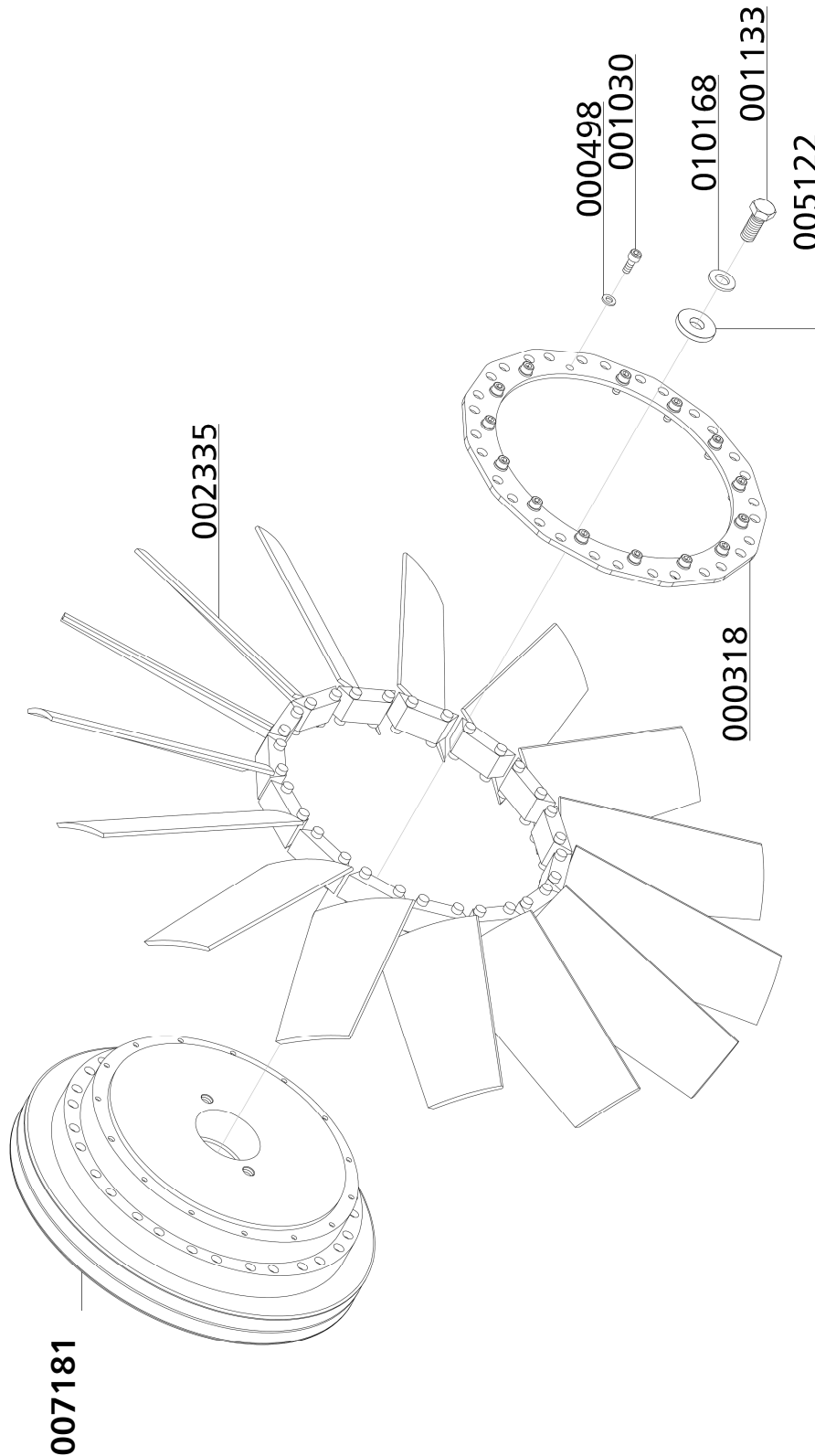



## ERSATZTEILLISTE / SPARE PART LIST

### Öl- / Wasserabscheider 1. Stufe / Oil- / Water Separator 1st Stage

Best.-Nr. / Order No.	Benennung	Description
000177	Trichter f. Wasserabscheider	Water Deflector
000220	Sicherheitsventil G3/8"	Safety Valve G3/8" 8 bar
000379	Wasserabscheider - Oberteil G1/2" IG	Top Water Separator 1/2"female
000391	U-Sit Ring	Seal Ring U-Sit
000564	Öl-/Wasserabscheider - Druckbehälter	Container Water Separ.
000738	Gerade Verschraubung	Straight Connection
000799	Verschraubung	Connection with fixed nut
000818	Verschraubung	Connection
000837	Verschlussstopfen	Plug
000838	Verschlussstopfen	Plug
000869	Verschraubung	Connection
001133	6-kant Schraube	Hexagon Bolt M12x30
001191	U-Scheibe A12	Washer A12
001192	Federring A12	Spring Washer A12
001272	O-Ring	O-Ring Water separator
001546	Aludichtring für Magnetventile G1/4"	Alloy Seal Ring for G1/4" male
002914	Sinterfilter für Wasserabscheidersockel	Sintered filt. water sep. base
003110	Sockel Wasserabscheider	Water separator base
003348	Filterverschraubung für Wasserabscheider	Connec. for sintered filter
006113	Magnetventil 0-55 bar	Solenoid 0-55 bar
006845	Stopfmutter Edelstahl	Lock Nut M6 s/s
010689	Öl-/ Wasserabscheider 1.- / 2.Stufe	Oil-/ Water Separator 1st- and 2nd Stage

**DETAILANSICHT / DETAILED VIEW**

**Öl- / Wasserabscheider 1. Stufe / Oil- / Water Separator 1st Stage**

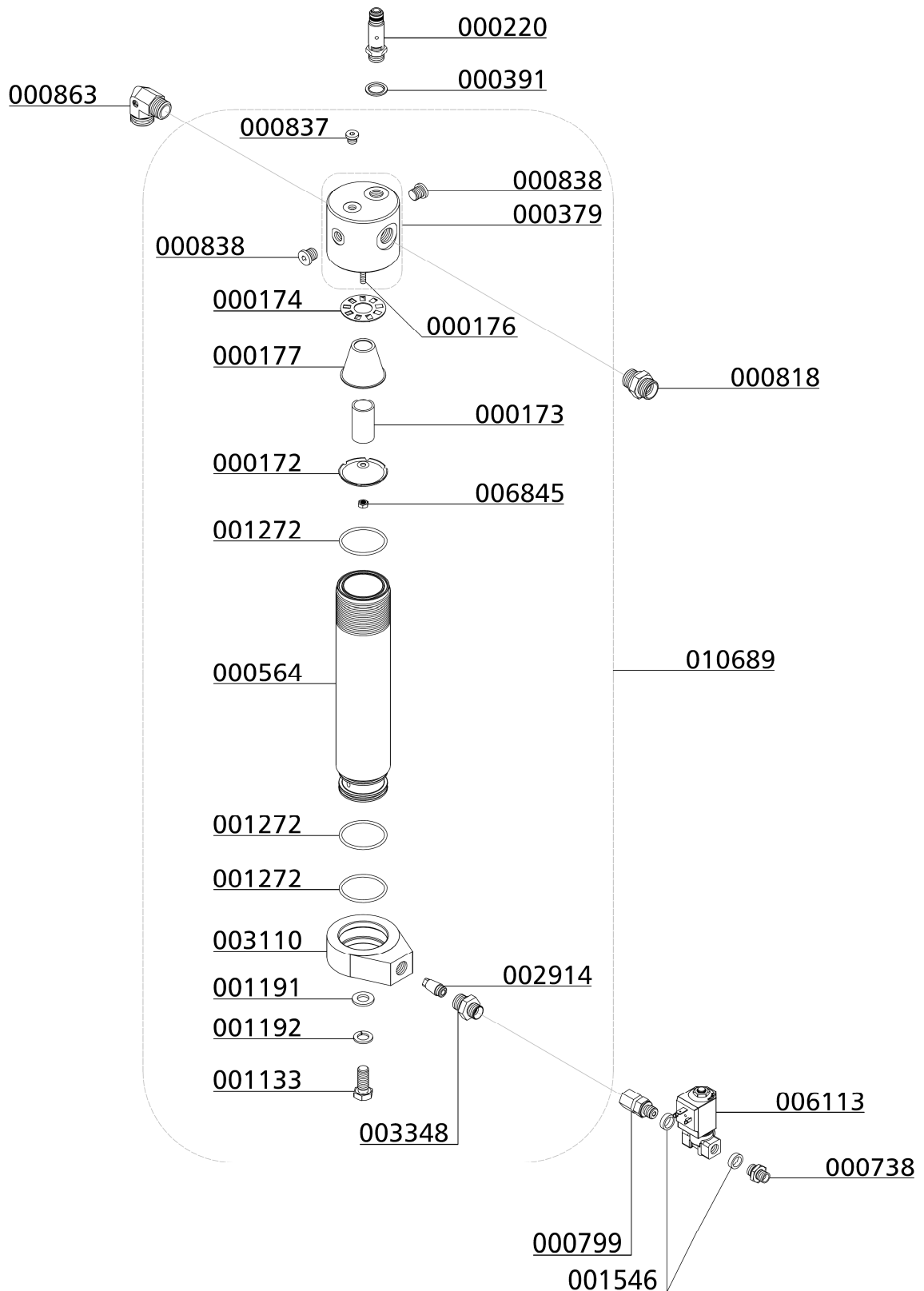

C



## ERSATZTEILLISTE / SPARE PART LIST

### Öl- / Wasserabscheider 2. Stufe / Oil- / Water Separator 2nd Stage

Best.-Nr. / Order No.	Benennung	Description
000172	Prallscheibe	Mounting plate water separator
000173	Sinterfilter Wasserabscheider	Sintered Filter Water separat.
000174	Drallscheibe, Wasserabscheider	Twist Disk, Water separator
000176	Stiftschraube, Wasserabscheider 2. Stufe	Treaded Stud
000177	Trichter f. Wasserabscheider	Water Deflector
000379	Wasserabscheider - Oberteil G1/2" IG	Top Water Separator 1/2"female
000380	Sicherheitsventil G3/8"	Safety Valve G3/8" 22 bar
000391	U-Sit Ring	Seal Ring U-Sit
000564	Öl-/Wasserabscheider - Druckbehälter	Container Water Separ.
000738	Gerade Verschraubung	Straight Connection
000799	Verschraubung	Connection with fixed nut
000810	Verschraubung	Connection
000837	Verschlussstopfen	Plug
000838	Verschlussstopfen	Plug
000866	Verschraubung	Connection
001133	6-kant Schraube	Hexagon Bolt M12x30
001191	U-Scheibe A12	Washer A12
001192	Federring A12	Spring Washer A12
001272	O-Ring	O-Ring Water separator
001546	Aludichtring für Magnetventile G1/4"	Alloy Seal Ring for G1/4" male
002914	Sinterfilter für Wasserabscheidersockel	Sintered filt. water sep. base
003110	Sockel Wasserabscheider	Water separator base
003348	Filterverschraubung für Wasserabscheider	Connec. for sintered filter
006113	Magnetventil 0-55 bar	Solenoid 0-55 bar
006845	Stopfmutter Edelstahl	Lock Nut M6 s/s
010689	Öl-/ Wasserabscheider 1.- / 2.Stufe	Oil-/ Water Separator 1st- and 2nd Stage

C

**DETAILANSICHT / DETAILED VIEW**

**Öl- / Wasserabscheider 2. Stufe / Oil- / Water Separator 2nd Stage**

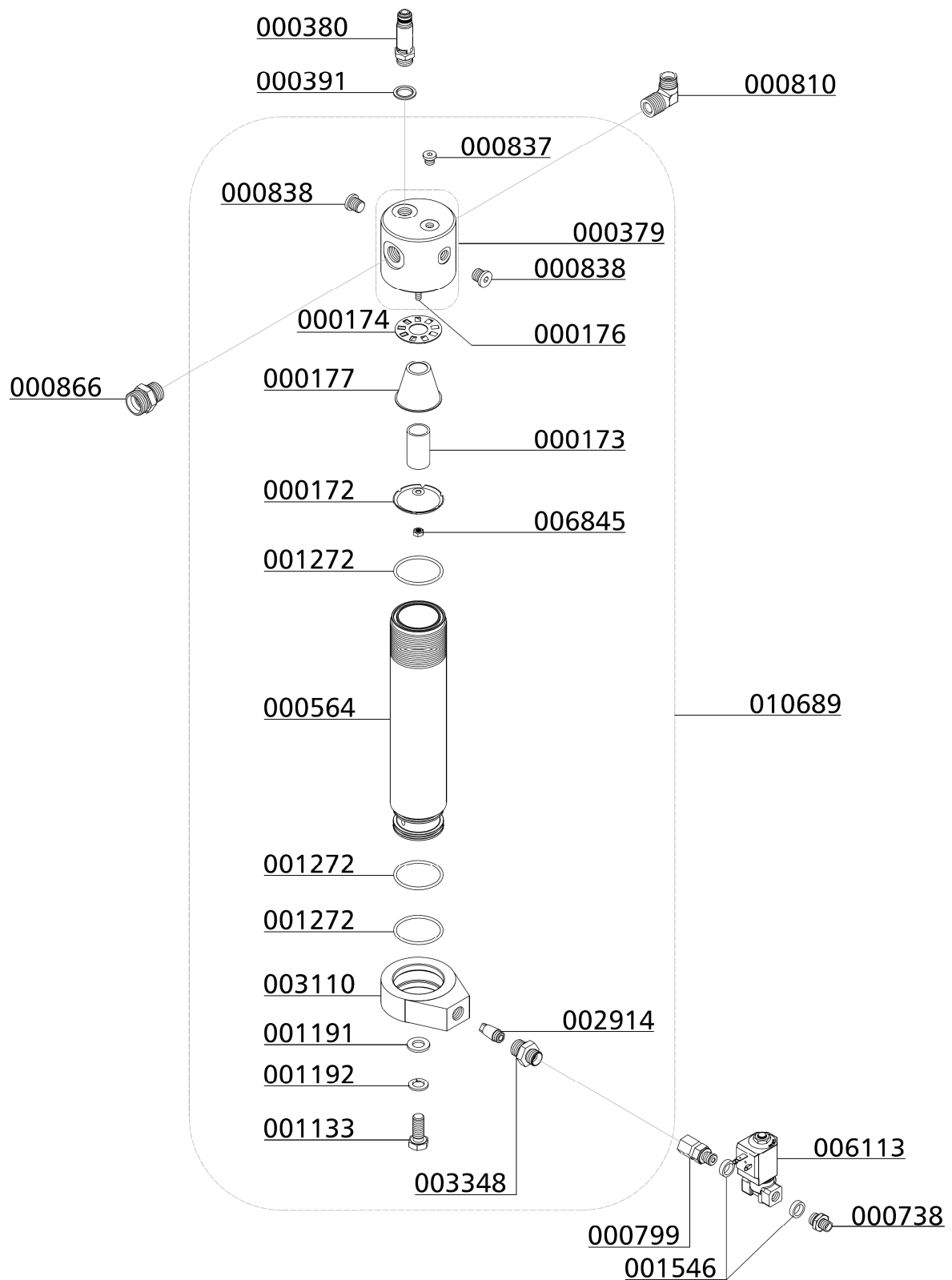

C

**Öl- / Wasserabscheider 3. Stufe / Oil- / Water Separator 3rd Stage**

Best.-Nr. / Order No.	Benennung	Description
000172	Prallscheibe	Mounting plate water separator
000173	Sinterfilter Wasserabscheider	Sintered Filter Water separat.
000174	Drallscheibe, Wasserabscheider	Twist Disk, Water separator
000176	Stiftschraube, Wasserabscheider 2. Stufe	Treaded Stud
000177	Trichter f. Wasserabscheider	Water Deflector
000379	Wasserabscheider - Oberteil G1/2" IG	Top Water Separator 1/2"female
000381	Sicherheitsventil G3/8"	Safety Valve G3/8" 90 bar
000391	U-Sit Ring	Seal Ring U-Sit
000564	Öl-/Wasserabscheider - Druckbehälter	Container Water Separ.
000761	Winkerverschraubung	Elbow Connection
000837	Verschlussstopfen	Plug
000838	Verschlussstopfen	Plug
000921	Reduzierung	Reducer
001133	6-kant Schraube	Hexagon Bolt M12x30
001191	U-Scheibe A12	Washer A12
001192	Federring A12	Spring Washer A12
001272	O-Ring	O-Ring Water separator
002914	Sinterfilter für Wasserabscheidersockel	Sintered filt. water sep. base
003110	Sockel Wasserabscheider	Water separator base
006845	Stopfmutter Edelstahl	Lock Nut M6 s/s
008827	Kondensat-Stopp-Ventil Einsatz	Condensate-Stop-Valve Assembly
009693	Filterverschraubung für Wasserabscheider	Connec. for sintered filter
010690	Öl-/ Wasserabscheider 3. Stufe	Oil-/ Water Separator 3rd Stage

**DETAILANSICHT / DETAILED VIEW**

**Öl- / Wasserabscheider 3. Stufe / Oil- / Water Separator 3rd Stage**

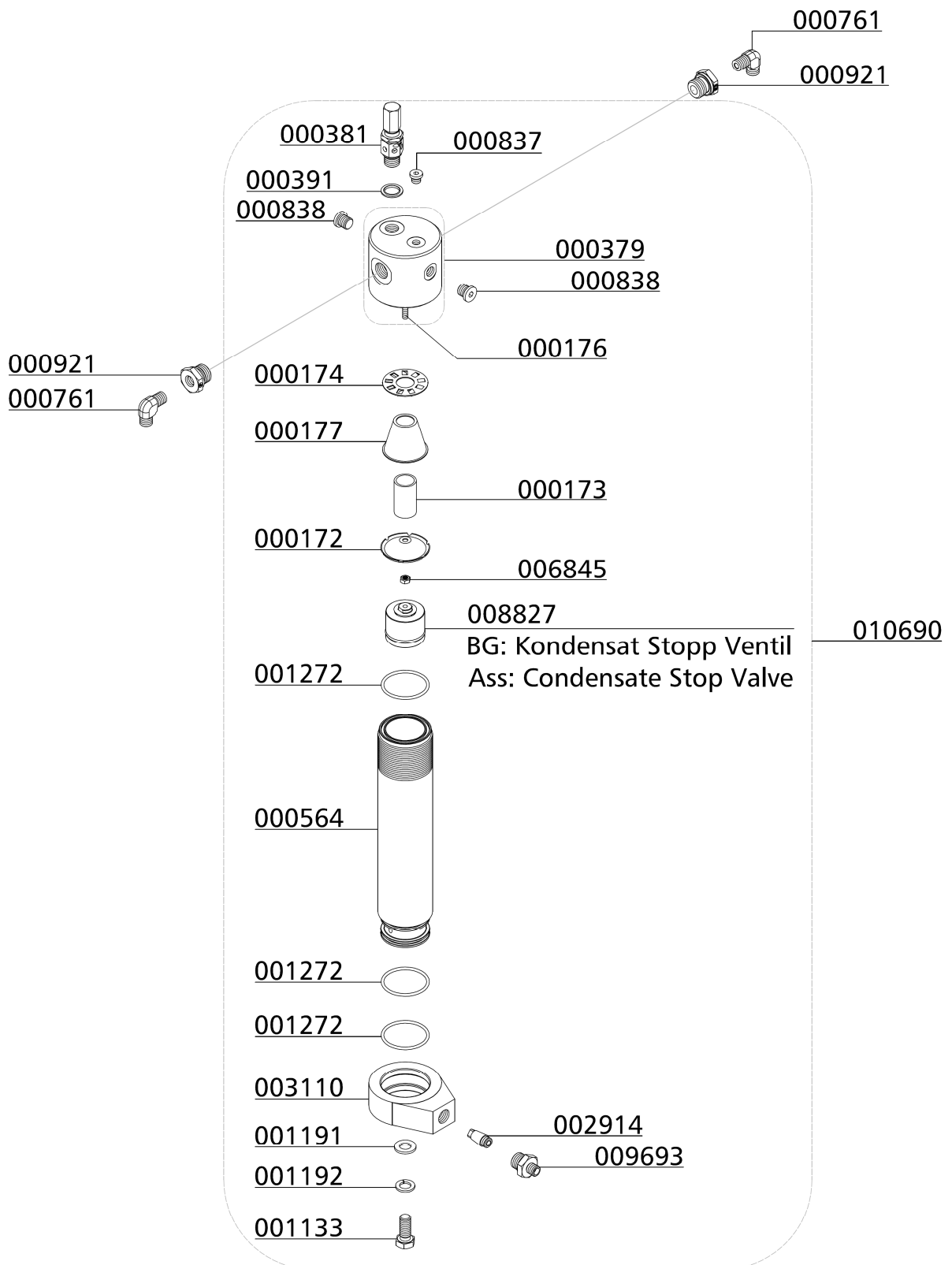

C



## ERSATZTEILLISTE / SPARE PART LIST

### Filter 0,8l / Filter 0.8ltr

Best.-Nr. / Order No.	Benennung	Description
000761	Verschraubung WE08LRFCX	Elbow Connection WE08LRFCX
000838	Verschlussstopfen VSTIR1/4EDCF	Plug VSTIR1/4EDCF
000921	Reduzierung RI1/2X1/4CFX	Reducer RI1/2X1/4CFX
001040	Zylinderschraube M8x20mm DIN912 8.8 ZN	Allen Screw M8x20mm DIN912 8.8 ZN
001159	Stopfmutter M8	Lock Nut M8
001181	U-Scheibe A8 DIN125 ZN	Washer A8 DIN125 ZN
001244	O-Ring Ø16 x 2 NBR70	O-Ring Ø16 x 2 NBR70
003980	Partikelfilterpatrone	Particle filter cartridge
003994	Filterbehälter 350 bar, 0,8 l, komplett	Filter case 350 bar, 0.8ltr, complete
003997	Filterstütze Partikelfilter 0,8 l	Filter support 0,8 ltr
004221	O-Ring, 54,2 x 3,0 FKM80	O-Ring, 54,2 x 3,0 FKM80
004222	Stützring 55,4x60x1,4	Back-up Ring 55,4x60x1,4
006363	Haltebügel Filtergehäuse 0,8 l	U-Clamp Filterhousing 0.8 ltr
006364	Halteschalen Filtergehäuse 0,8 l	Bracket Filter Housing 0.8 ltr
009031	Verschlussstopfen für CE-TÜV Sicherheitsventilsockel	Plug for CE Safety Valve Base

C



**DETAILANSICHT / DETAILED VIEW**

**Filter 0,8l / Filter 0.8ltr**

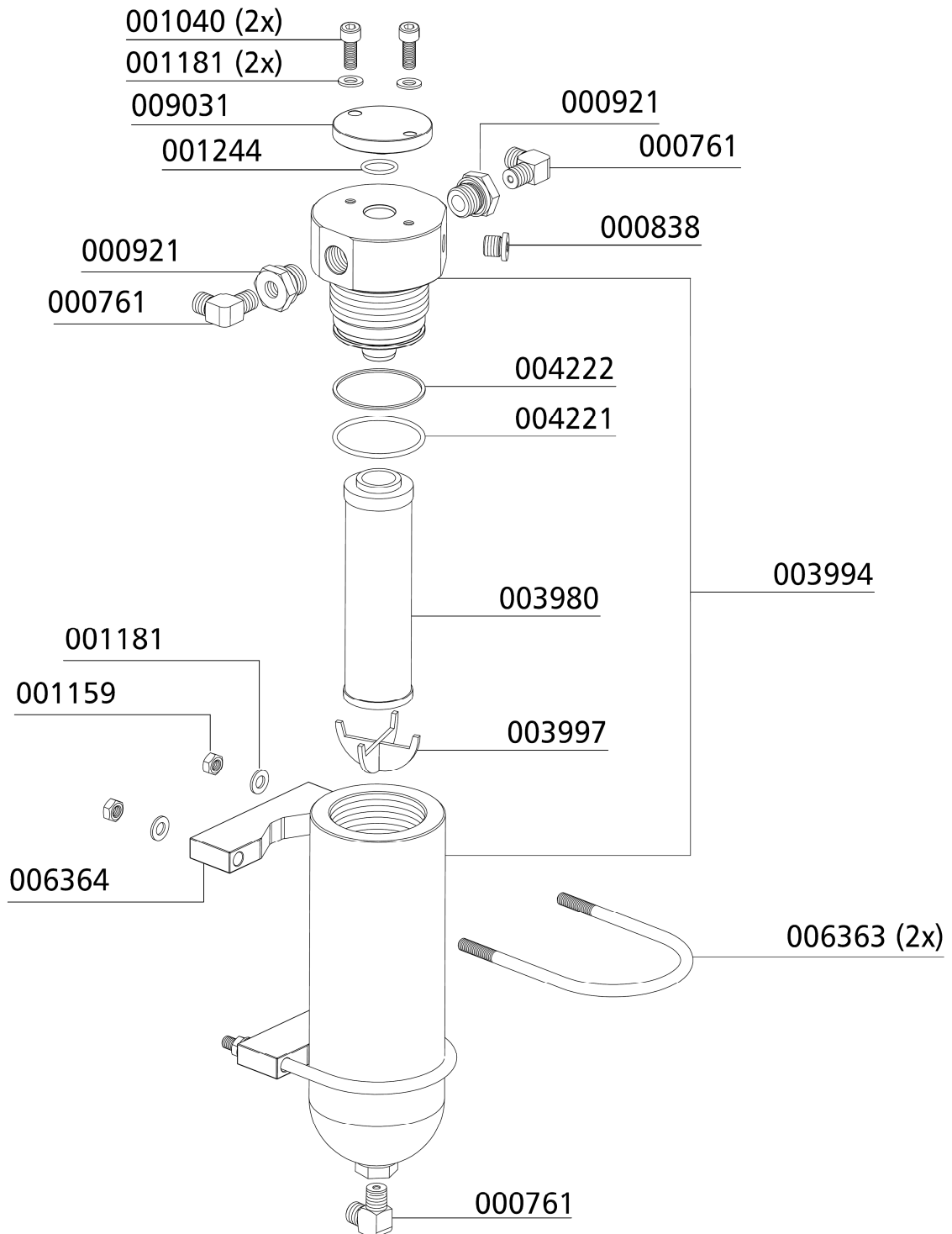

C



## ERSATZTEILLISTE / SPARE PART LIST

### Magnetventil mit Rückschlagventil / Solenoid Valve with Non-Return Valve

Best.-Nr. / Order No.	Benennung	Description
000741	Verschraubung, GE08LR3/8CFX	Connection, GE08LR3/8CFX
000749	Verschraubung mit fester Mutter, EVGE 08 PLR-ED	Connection with fixed nut, EVGE 08 PLR-ED
000757	T-Verschraubung mit fester Mutter, EVL08LOMDCF	T-Connection with fixed nut, EVL08LOMDCF
000765	Schneidring, PSR 08 LX	Olive Seal, PSR 08 LX
000766	Mutter, M08LCFX	Nut, M08LCFX
001472	Magnetventil, Edelstahl, 350bar 230V/50Hz	Solenoid, s/s, 350 bar 230V/50Hz
001546	Aludichtring für Magnetventile G1/4"	Alloy Seal Ring for G1/4" male
003159	Sinterfilter G1/4" mit Schlitz	Sintered filter G1/4" male with slot
003707	Rückschlagventil, Stahl, 2 x G3/8"	Non-Return Valve, steel, 2 x G3/8"

C

**DETAILANSICHT / DETAILED VIEW**

**Magnetventil mit Rückschlagventil / Solenoid Valve with Non-Return Valve**

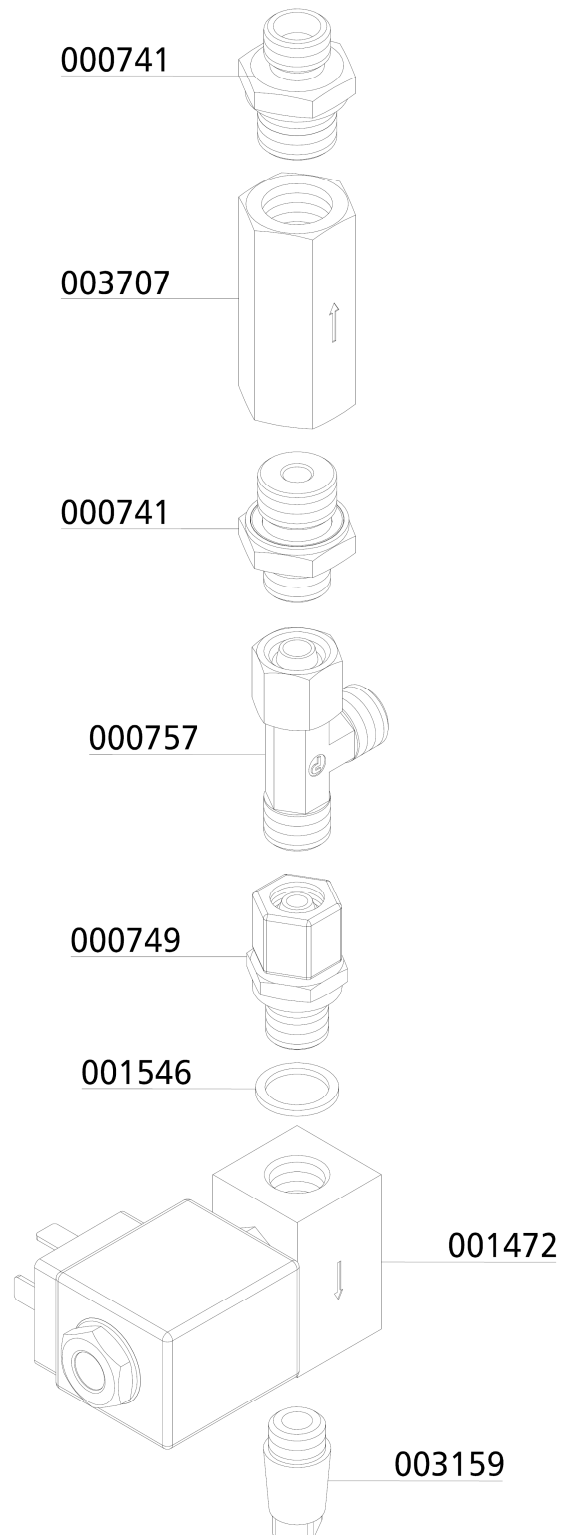

C



## ERSATZTEILLISTE / SPARE PART LIST

### Filtergehäuse 2,3 l / Filter Housing 2.3 ltr

Best.-Nr. / Order No.	Benennung	Description
000003	Filterpatrone 2,3 Liter	Filter Cartridge 2.3 ltr BA
000272	Abstandshalter für Filtergehäuse	Spacer Bracket for Filtertower
000383	Messing Adapter für Filterpatrone	Brass Filter Adapter
000384	Düse für Filtergehäuse	Jet Filter Housing
000761	Winkerverschraubung	Elbow Connection
001159	Stopfmutter	Lock Nut M8
001181	U-Scheibe A8	Washer A8
001285	Stützring, Filtergehäuse	Back-up Ring Filter Housing
001287	O-Ring, Filtergehäuse	O-Ring filter housing
002140	Filterschlüssel 1,7 & 2,3 Liter Behälter	Filter tool 1,7 & 2,3 Litre
002426	Filtergehäuse, kompl.	Filter housing
003077	Entwässerungsventil G1/4" AG, konisch	Drain Valve G1/4" male
010985	Abstandshalter für Filtergehäuse	Spacer Filter Housing
010986	Haltebügel für Filtergehäuse (ES)	U-Clamp for filter housing ES

C

**DETAILANSICHT / DETAILED VIEW**

**Filtergehäuse 2,3 l / Filter Housing 2.3 ltr**

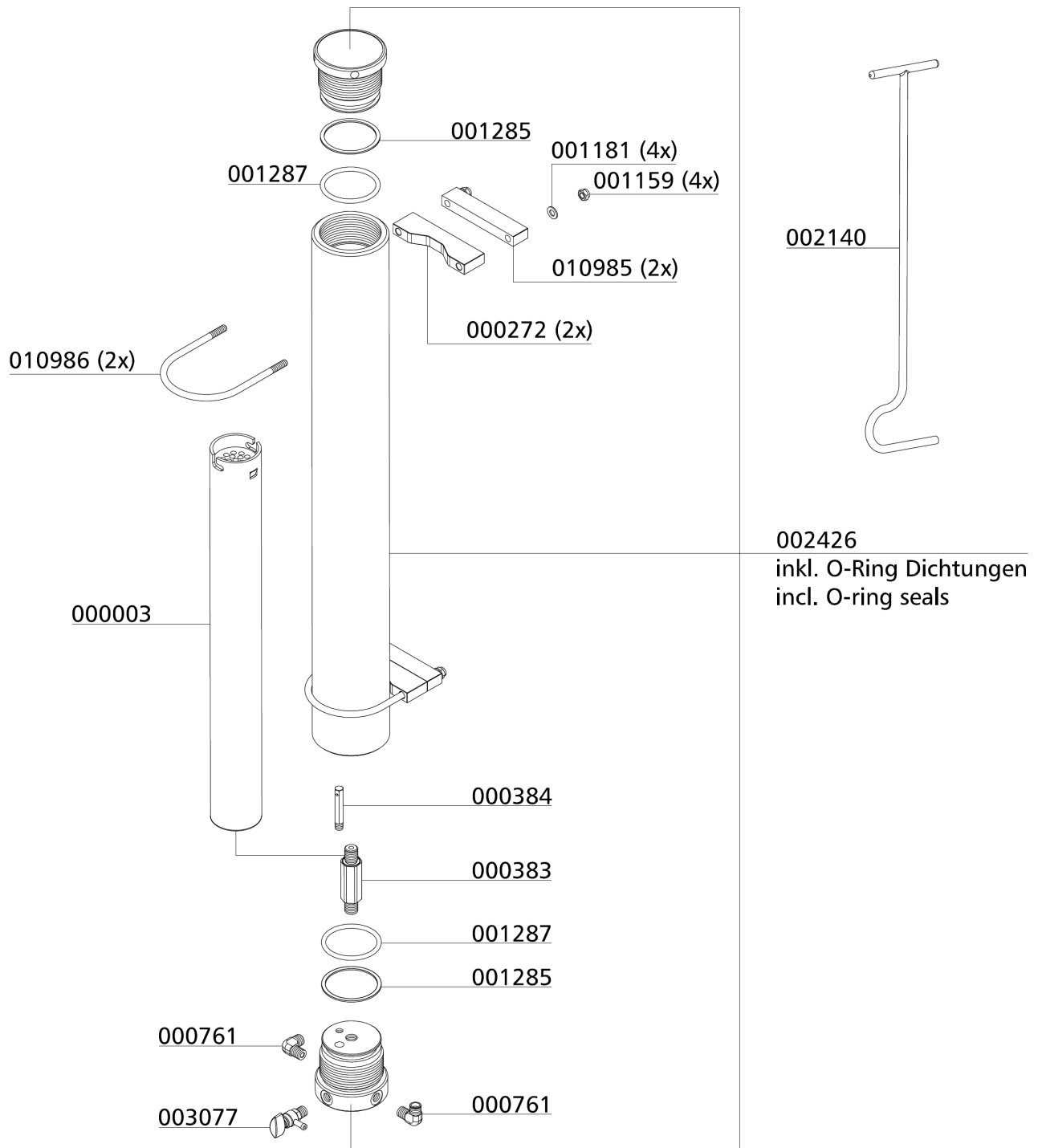

**C**



## ERSATZTEILLISTE / SPARE PART LIST

---

### Baugruppe: Kondensat-Stopp-Ventil / Assembly: Condensate-Stop-Valve

Best.-Nr. / Order No.	Benennung	Description
000498	U-Scheibe DIN 125 A6	Washer DIN 125 A6
001156	Stopfmutter M6 DIN985 ZN	Lock Nut M6 DIN985 ZN
001264	O-Ring, 38 x 3 NBR70	O-Ring, 38 x 3 NBR70
006370	Gehäuse Kondensat-Stopp-Ventil	Housing-Condensate-Stop-Valve
006372	Ventilkegel Kondensat-Stopp-Ventil	Valve Condensate Stop Valve
006373	Stauscheibe Kondensat-Stopp-Ventil	Baffle Plate Condensate Stop Valve
006380	Druckfeder	Compression Spring
008827	Kondensat-Stopp-Ventil Einsatz	Condensate-Stop-Valve Assembly

C

**DETAILANSICHT / DETAILED VIEW**

**Baugruppe: Kondensat-Stopp-Ventil / Assembly: Condensate-Stop-Valve**

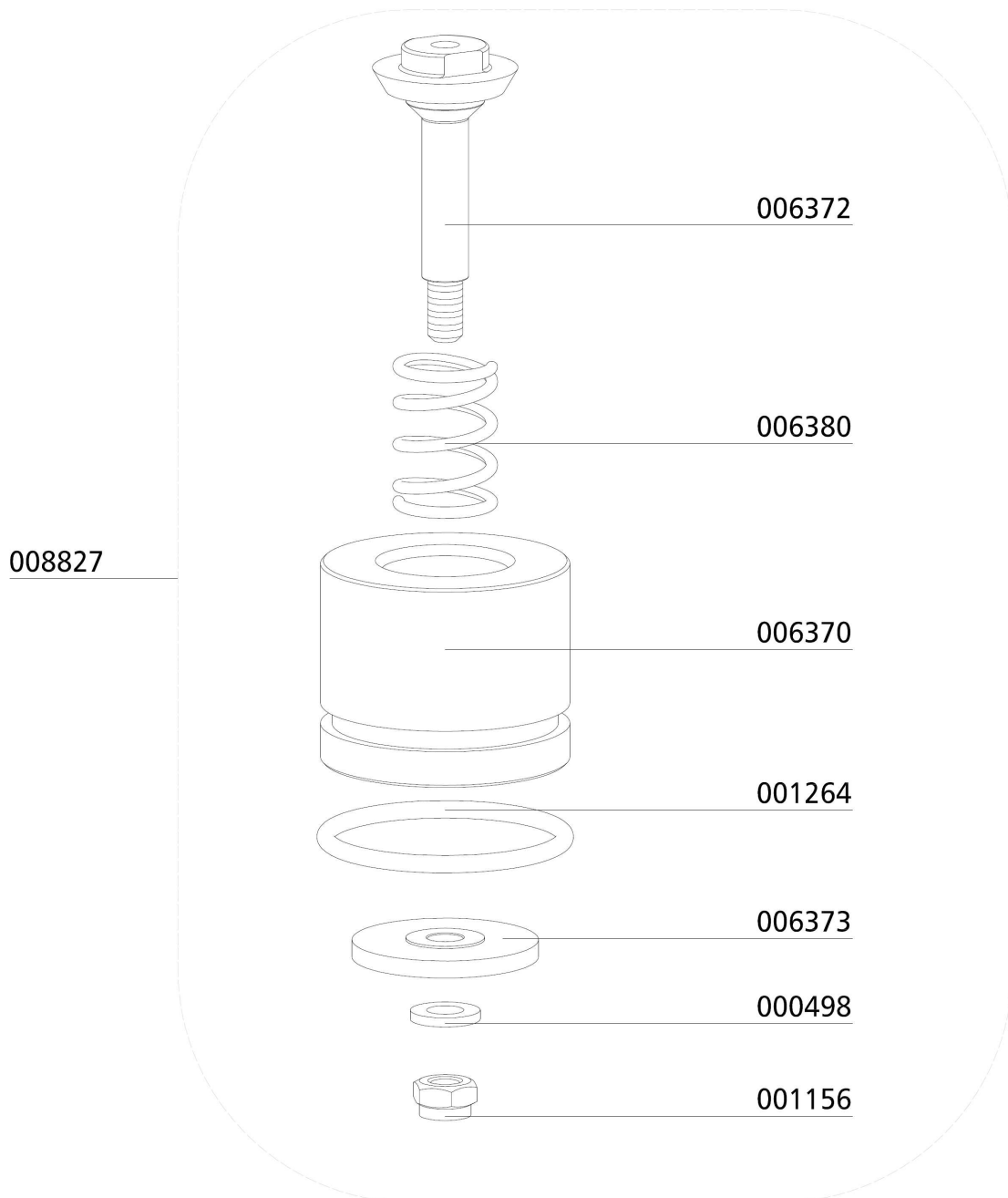

C



## ERSATZTEILLISTE / SPARE PART LIST

### Baugruppe: Kondensat-Stopp-Ventil-Gehäuse / Assembly: Housing Condensate-Stop-Valve

Best.-Nr. / Order No.	Benennung	Description
000739	Verschraubung GE08L/1/4KEGCFX	Connection GE08L/1/4KEGCFX
000741	Verschraubung, GE08LR3/8CFX	Connection, GE08LR3/8CFX
000765	Schneidring PSR 08 LX	Olive Seal PSR 08 LX
000766	Mutter M08LCFX	Nut M08LCFX
001055	Zylinderschraube, M8x55mm DIN912 8.8 ZN	Allen Screw, M8x55mm DIN912 8.8 ZN
001184	Schnorr-Scheibe S8 N0110 ZN	Clamp Washer S8 S8 N0110 ZN
002914	Sinterfilter für Wasserabscheidersockel, M12x1,5mm AG	Sintered filt. water sep. Base, M12x1,5mm AG
006368	Behälter Kondensat-Stopp-Ventil	Container Condensate-Stop-Valve
006369	Behälterdeckel Kondensat-Stopp-Ventil	Cover Condensate-Stop-Valve
006382	O-Ring 38x3,5 NBR90	O-Ring 38x3,5 NBR90
008827	Kondensat-Stopp-Ventil Einsatz	Condensate-Stop-Valve Assembly
008828	Kondensat-Stopp-Ventil kompl., inkl. Ventileinsatz 008827	Condensate-Stop-Valve, compl., incl. valve assembly 008827

C



**DETAILANSICHT / DETAILED VIEW**

**Baugruppe: Kondensat-Stopp-Ventil-Gehäuse / Assembly: Housing Condensate-Stop-Valve**

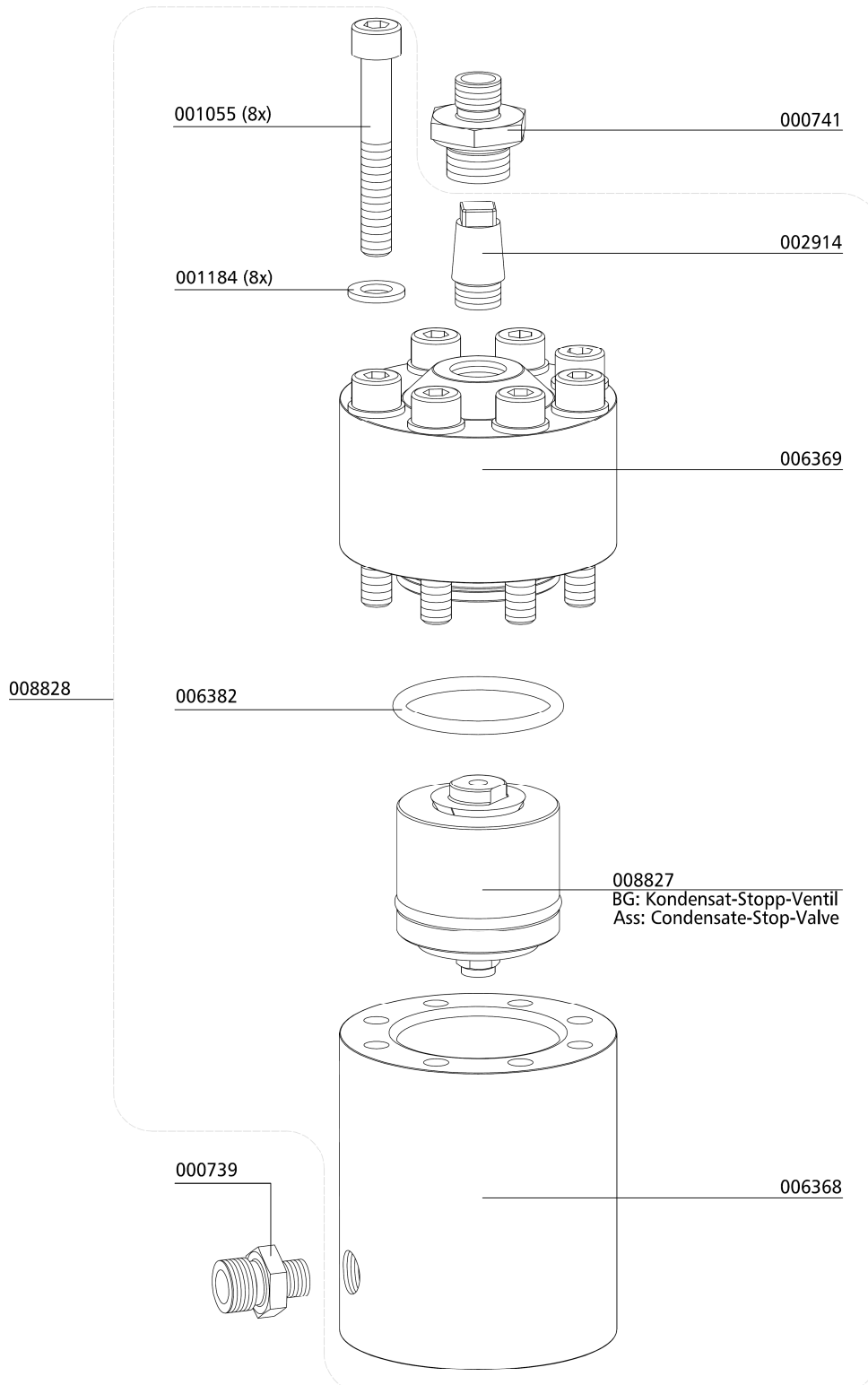

C



## ERSATZTEILLISTE / SPARE PART LIST

---

### Baugruppe: Verteilerblock / Assembly: Distributor Block

Best.-Nr. / Order No.	Benennung	Description
000738	Gerade Verschraubung	Straight Connection
000761	Winkelverschraubung	Elbow Connection
005842	Linsenflanschschraube mit Innensechskant	Lens Head Screw
006464	Verteilerblock Kondensatentwässerung	Distributor Block CD

C

**DETAILANSICHT / DETAILED VIEW**

---

**Baugruppe: Verteilerblock / Assembly: Distributor Block**

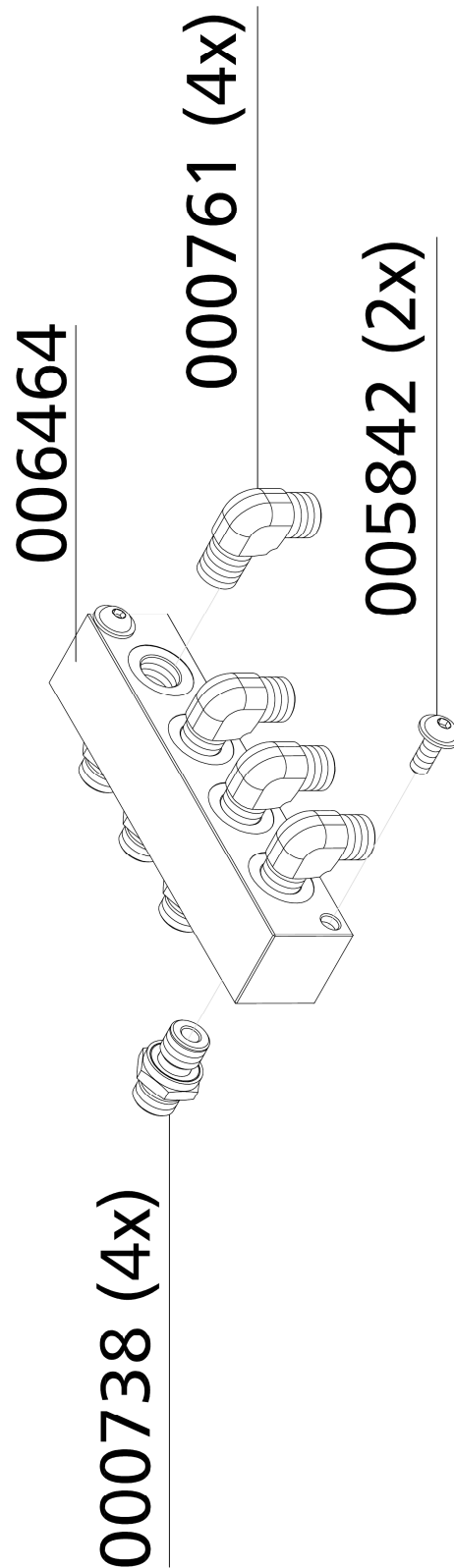

C

**Baugruppe: Kondensat-Sammelbehälter / Assembly: Housing Condensate-Catch-Tank**

Best.-Nr. / Order No.	Benennung	Description
000739	Verschraubung	Connection
001179	U-Scheibe A6	Washer A6
002152	O-Ring	O-Ring
004188	Verschlusschraube G3/4	Plug G3/4
005842	Linsenflanschschraube mit Innensechskant	Lens Head Screw
006356	Kondensatbehälter 10 Liter	Condensate Catch Tank 10 Litre
006379	Zugfeder Kondensatfilterpatrone	Spring Condensate Filter Cartr
006459	Adapter Kondensatbehälter	Adapter Condensate Catch Tank
006460	Federspannblech Kondensatbehälter	Spring Clamping Plate CCT
006461	Halteblech Kondensatbehälter	Bracket Condensate Catch Tank
006462	Filter Kondensatbehälter	Filter Condensate Catch Tank
008357	Verschlusskappe für 006356	Cap for Condensate Catch Tank
008655	Linsenflanschschraube mit Innensechskant	Lens Head Screw
009995	Kondensatschlauch, Ø8x1,5, L: 565mm	Condensate Hose Ø8x565mm
009996	Kondensatschlauch, Ø8x1,5, L: 580mm	Condensate Hose Ø8x580mm
009997	Kondensatschlauch, Ø8x1,5, L: 612mm	Condensate Hose Ø8x612mm
010010	Kondensatschlauch, Ø8x1,5, L: 532mm	Condensate Hose Ø8x532mm

**C**

**DETAILANSICHT / DETAILED VIEW**

**Baugruppe: Kondensat-Sammelbehälter / Assembly: Housing Condensate-Catch-Tank**

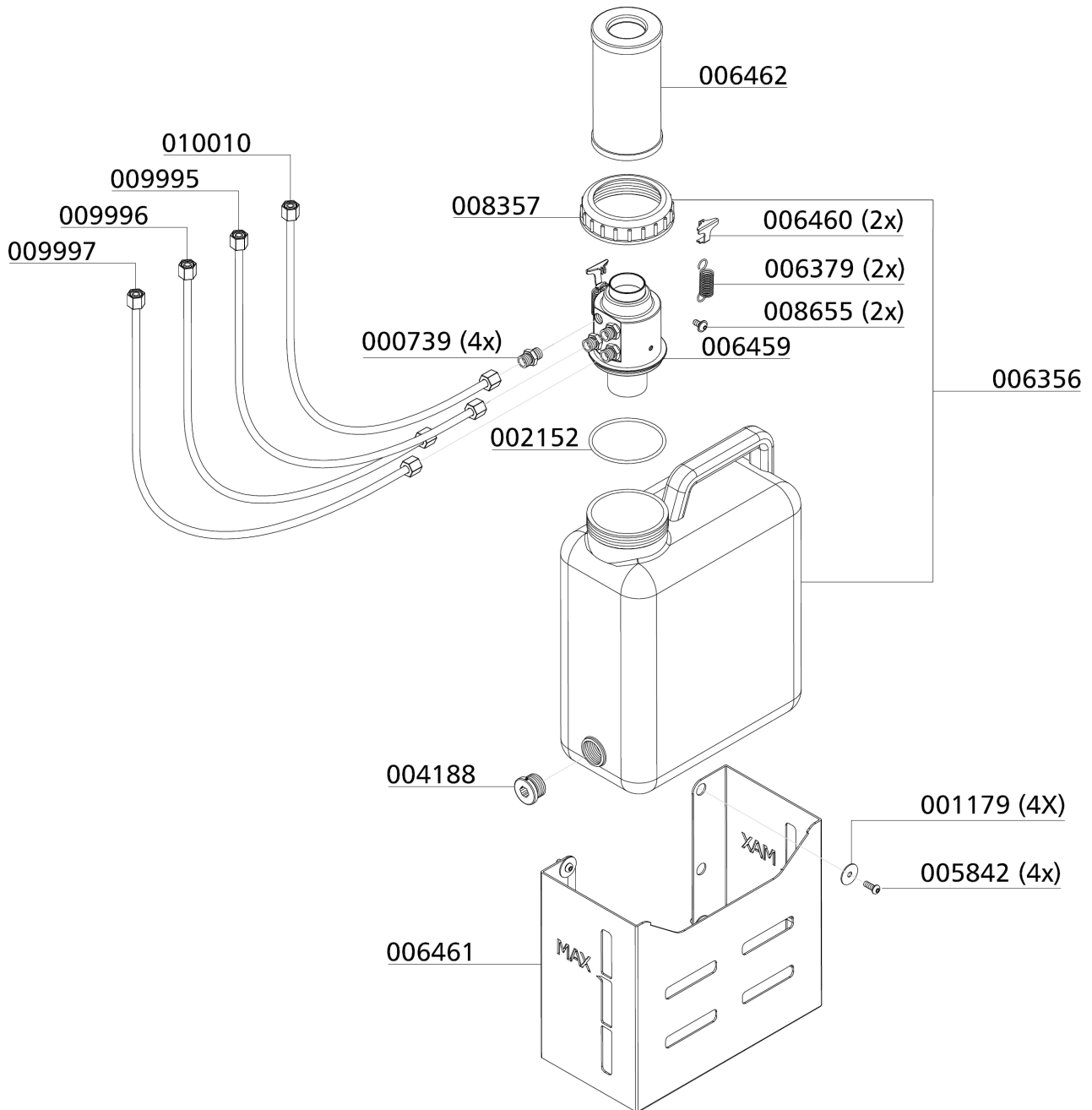

C



## ERSATZTEILLISTE / SPARE PART LIST

### Sicherheitsventil / Safety Valve

Best.-Nr. / Order No.	Benennung	Description
000233	Sockel für Sicherheitsventil mit TÜV/CE	Base f. Safety Valve TÜV type
000553	Sicherheitsventil - Bauteilgeprüft	Safety Valve TÜV 225 bar
000554	Sicherheitsventil - Bauteilgeprüft	Safety Valve TÜV 250 bar
000555	Sicherheitsventil - Bauteilgeprüft	Safety Valve TÜV 300 bar
000556	Sicherheitsventil - Bauteilgeprüft	Safety Valve TÜV 330 bar
000557	Sicherheitsventil - Bauteilgeprüft	Safety Valve TÜV 350 bar
000738	Gerade Verschraubung	Straight Connection
001044	Zylinderschraube	Allen Screw
001058	Zylinderschraube	Allen Bolt
001159	Stopfmutter	Lock Nut M8
001181	U-Scheibe A8	Washer A8
001244	O-Ring	O-Ring, flange safety valve
001814	Sicherheitsventil - Bauteilgeprüft	Safety Valve
001815	Sicherheitsventil - Bauteilgeprüft	Safety Valve
001816	Sicherheitsventil - Bauteilgeprüft	Safety Valve
001817	Sicherheitsventil - Bauteilgeprüft	Safety Valve

## DETAILANSICHT / DETAILED VIEW

### Sicherheitsventil / Safety Valve

Druck Pressure	SV-Ventil mit CE-Prüfung Safety Valve with CE	SV-Ventil mit TÜV-Prüfung Safety Valve with TÜV
225 bar	001814	000553
250 bar	001815	000554
285/300 bar	-----	000555
330 bar	001816	000556
350 bar	001817	000557

Sonder-Einstelldrücke auf Anfrage!

Special relieve pressures are available on request!

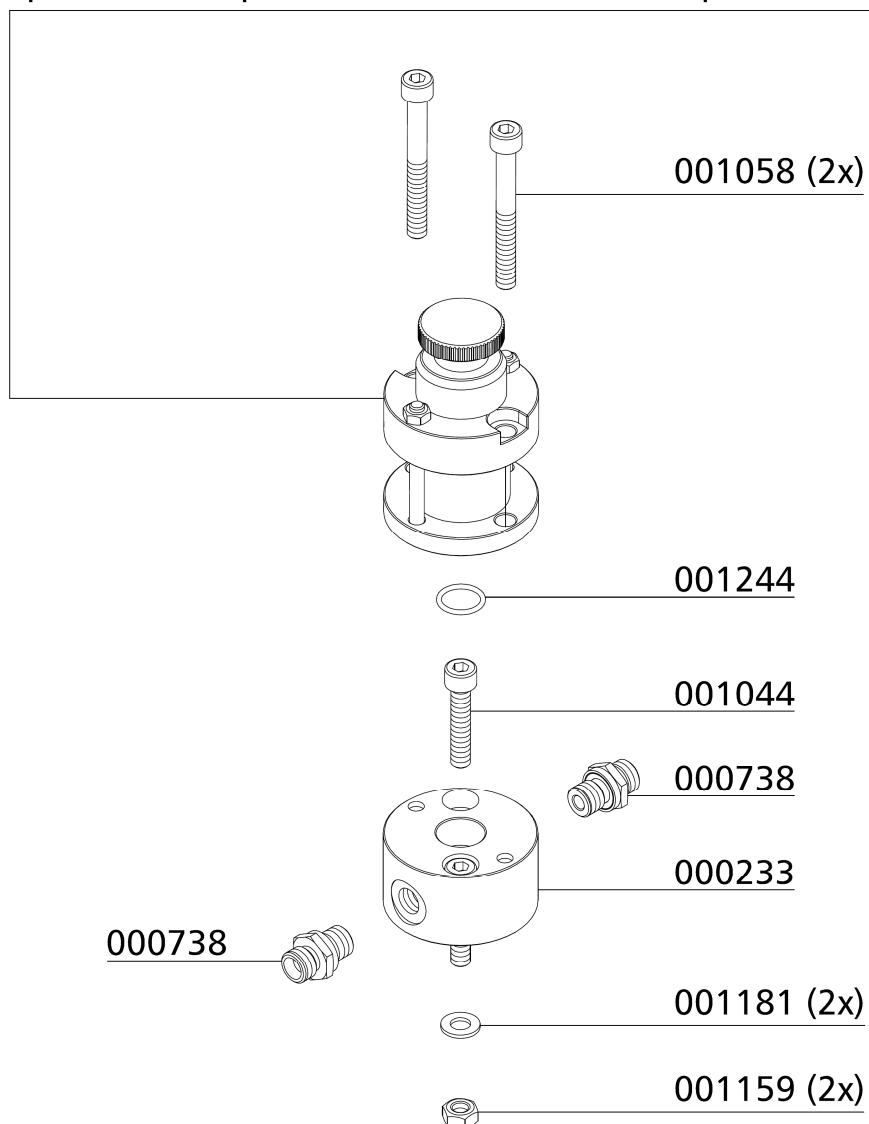



## ERSATZTEILLISTE / SPARE PART LIST

### Pneum. Kondensat-Ablassventil / Pneumatic Condensate Valve

Best.-Nr. / Order No.	Benennung	Description
000188	Sinterfilter, pneum. Kondensatventil	Sintered Filter
000191	Steuerkolben, pneum. Kondensatventil	Piston
000194	Reparatursatz pneum. Kondensatventil	Repair Kit Condensate Valve
000196	Düsenschraube, pneum. Kondensatventil	Inlet Jet Screw
000197	Stopfen, pneum. Kondensatventil	Plug
000198	Gehäuse, pneum. Kondensatventil	Body PCV
000199	Pneum. Kondensatventil (Kondensatablas.)	Pneumatic Condensate Valve
000498	U-Scheibe A6	Washer A6
000616	Magnetventil 80 bar	Solenoid 80 bar
000710	Verschraubung	Connection w/o nut& olive seal
000738	Gerade Verschraubung	Straight Connection
000759	Winkelverschraubung	Elbow connection
000892	Doppelnippel	Double Nipple
001011	Zylinderschraube	Allen Bolt
001546	Aludichtring für Magnetventile G1/4"	Alloy Seal Ring for G1/4" male

C



**DETAILANSICHT / DETAILED VIEW**

**Pneum. Kondensat-Ablassventil / Pneumatic Condensate Valve**

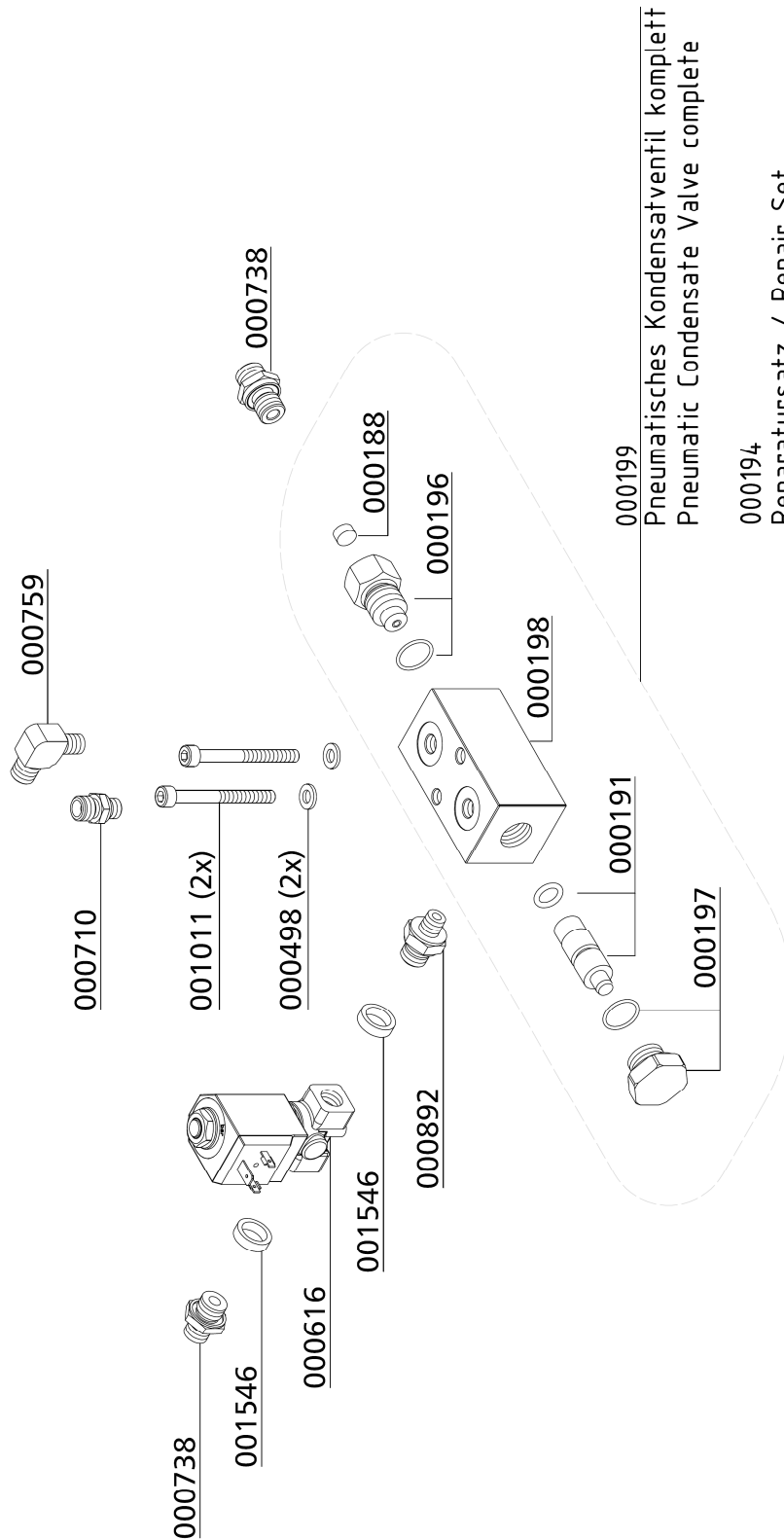



## ERSATZTEILLISTE / SPARE PART LIST

### Druckhalte- Rückschlagventil / Pressure Maintaining- Non-Return Valve

Best.-Nr. / Order No.	Benennung	Description
000169	Druckhalterückschlagventil	Pressure Maint. Valve black
000498	U-Scheibe A6	Washer A6
000506	Druckfeder	Spring
000508	USIT Ring	Gasket Ring U-Sit
000511	Mutter, DHRV	Lock Nut PMV
000512	Einstellschraube, DHRV	Set Bolt PMV
000513	Druckstück, DHRV	Spring Adapter PMV,
000514	Stift, DHRV	Stud PMV
000515	Gehäuse, DHRV	Main Body PMV
000516	Nutring, DHRV	Seal Ring PMV
000517	Druckfeder, DHRV	Coil Spring PMV
000518	U-Scheibe	Washer, M5, brass
000519	Dichtkappe, DHRV	Plastic Seal Piston PMV
000520	Eingangsdüse	Inlet Jet PMV (black version)
000738	Gerade Verschraubung	Straight Connection
003548	Reparatursatz DHRV	Repair kit, PMV
006278	Zylinderschraube	Allen Bolt

C

**DETAILANSICHT / DETAILED VIEW**

**Druckhalte- Rückschlagventil / Pressure Maintaining- Non-Return Valve**

**Reparatursatz  
003548:**

Bestehend aus:  
Gelbmarkierten  
Bestellnummern

**Repair kit  
003548:**

Consists of:  
Yellow marked  
order numbers

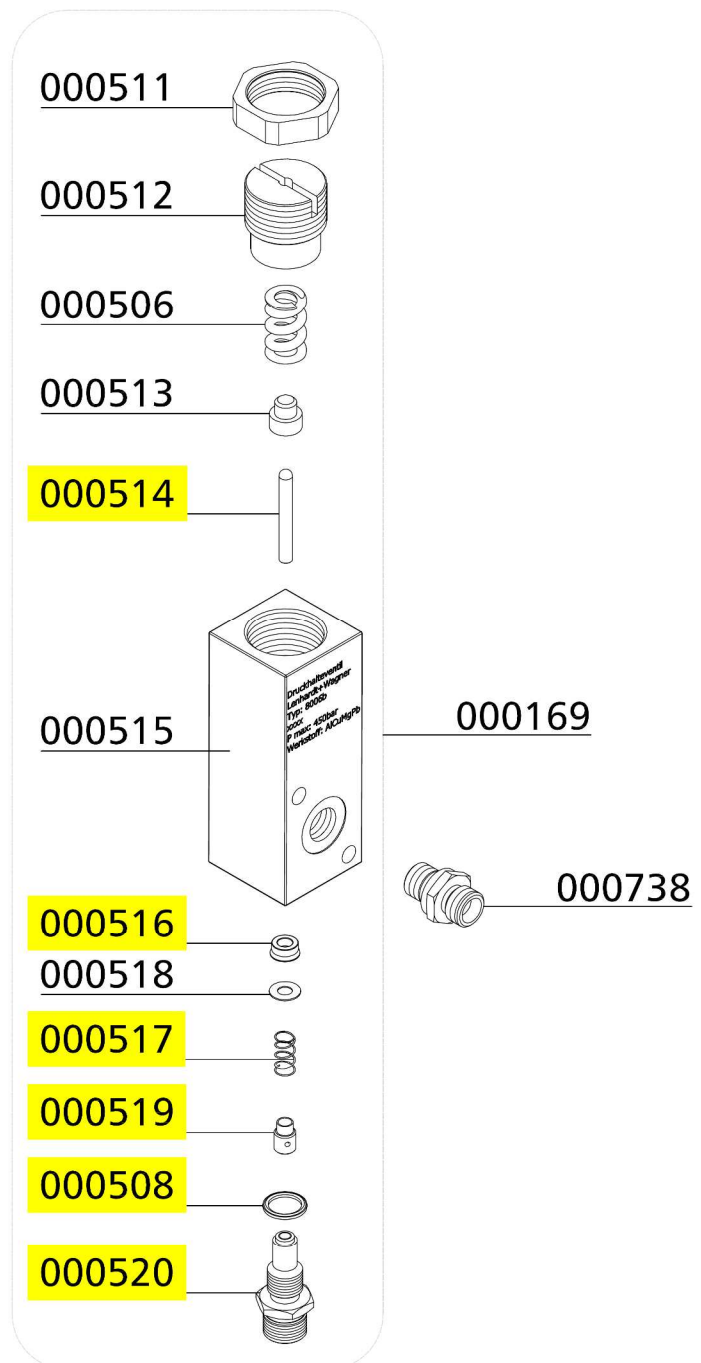
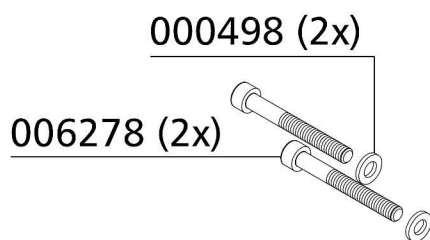

C



## ERSATZTEILLISTE / SPARE PART LIST

---

### Druckschalter / Pressure Switch

Best.-Nr. / Order No.	Benennung	Description
000203	Druckschalter, G1/4" IG, PV 50 - 350 bar	Pressure Switch 50-350 bar
000764	Winkelverschraubung mit fester Mutter	Elbow Connection c/w fixed nut EW08L
000753	T-Verschraubung	T-Connection T08L
009683	Winkelverschraubung mit fester Mutter	Elbow Connection c/w fixed nut EGE08L

C

**DETAILANSICHT / DETAILED VIEW**

---

**Druckschalter / Pressure Switch**

C

**000753**

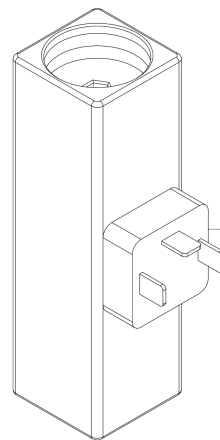
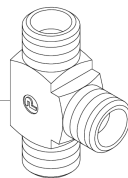

**000203**

**009683**



**000764**

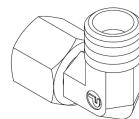



## ERSATZTEILLISTE / SPARE PART LIST

### Baugruppe: Motor / Assembly: Engine

Best.-Nr. / Order No.	Benennung	Description
000217	Ventilatorflansch, Zusatzlüfter	Cooling Fan Adapter Flange
001040	Zylinderschraube	Allen Screw
001044	Zylinderschraube	Allen Screw
001165	Mutter	Nut M12
001167	Stopmmutter M12	Lock Nut M12
001181	U-Scheibe A8	Washer A8
001191	U-Scheibe A12	Washer A12
001192	Federring A12	Spring Washer A12
001413	Keilriemen (50 HZ)	V-Belt XPA 1757
005122	U-Scheibe Kurbelwelle	Washer, crank shaft
005689	Spannbuchse für Riemenscheibe	Taper bush
006095	Schlossschraube	Carriage Bolt
006248	U-Scheibe A13	Washer A13
006630	Spannbuchse für Riemenscheibe	Clamping bush, pulley
009515	Zusatzventilator Silent Lüfterrad	Additional Impeller SILENT
009985	Augenschraube M12x100mm	Eye Bolt M12x100mm
010638	Verdrehschutz-Schlossschraube-M12	Carriage Bolt Safety Plate
010649	Ventilatorflansch, Zusatzlüfter	Cooling Fan Adapter Flange
010652	Zusatzventilator Silent Lüfterrad	Additional Impeller SILENT
010681	Antriebsmotor 18,5kW - 160L, 400V	E-Motor 18,5kW
010686	Riemenscheibe	Pully SPA 150x2-2012
010694	Schlossschraube M12x75mm	Carriage Bolt M12x75mm
010695	Passfeder A12x8x90	Woodruff Key A12x8x90
010697	Riemenscheibe	Pully SPA 125x2-2012
010724	Antriebsmotor 18,5kW - 160L, 230V	E-Motor 18,5kW
010742	Keilriemen (60 HZ)	V-Belt SPA 1707
010931	Augenschraube	Eyebolt BM12x140mm
010984	Tellerfeder	Disc Spring
010995	Distanzscheibe Motorausrichtung	Spacer
011143	Schlossschraube M12x70mm	Carriage Bolt M12x70mm

C





## OPTIONS





## Table of Contents

---

Auto Start Function .....	1
Filling Device at Compressor .....	7
Integrated Filling Panel .....	11
200+300bar Parallel Filling Pressure Operation .....	16
Oil Pressure Gauge .....	24
Interstage Pressure Gauge .....	29
Oil Pressure Monitoring .....	33
Cylinder Head Temperature Monitoring .....	39
Oil Temperature Monitoring .....	42
Puracon Filter Monitoring .....	45
Block Heating Device .....	49
420bar Version .....	52
Phase Monitoring .....	61
Special Voltage .....	65
Air Cooler Connection Kit .....	71

---



# AUTO START FUNCTION

D

## AUTO START FUNCTION

### Auto Start Function

The auto start function allows operating the compressor optionally in automatic or semi-automatic mode by turning the selector switch.

#### Semi-Automatic Operation:

Start the compressor by pushing the Start button. The compressor automatically shuts off when final pressure is reached. To restart the compressor, push the Start button again. The unit can be shut down at any time during operation by pushing the Stop button.



Selector switch auto start function

#### Automatic Operation:

Start the compressor only once by pushing the Start button. The Start button lights up and the unit automatically shuts off when final pressure is reached. If outlet pressure decreases below the selected minimum pressure, the unit automatically restarts.



#### Note

The compressor can not be started manually during automatic operation.

To enable a manual start, shut off automatic operation by pushing the Stop button (Start button lamp goes out). Now turn selector switch to semi-automatic mode and start the compressor with the Start button.

### Adjust re-start pressure (minimum filling pressure)

The pressure switch for start pressure is located after the pressure maintaining valve. The pressure can be adjusted with the upper adjusting screw.

Increasing re-start pressure: turn adjusting screw clockwise

Reducing re-start pressure: turn adjusting screw anti-clockwise

Adjust pressure switch in steps of a quarter turn. Check settings after every adjustment step.

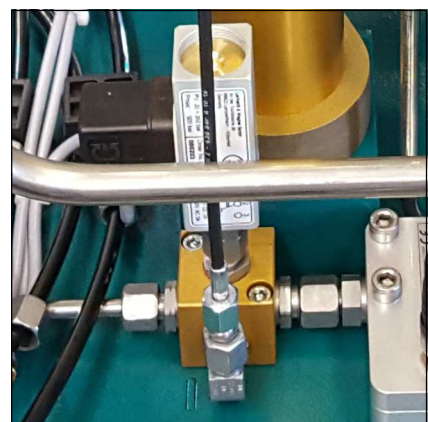

Pressure switch for start pressure

## AUTO START FUNCTION

---

### Filling Procedure Semi-Automatic Operation



**Caution! Only fill cylinders which:**

- are marked with the test mark and the test stamp of the expert.
- have been hydro static tested (check last test date).
- are rated for the final pressure.
- are free from humidity.



**Note**

The unit shuts down when final pressure is reached. Thus, the unit always has to be restarted manually.

1. Turn selector switch to semi-automatic mode.
2. Close all filling valves.
3. Connect closed compressed air cylinders.
4. Open cylinder valves.
5. Start compressor by pushing the ON button.
6. If the filling pressure increases, open the filling valves slowly.
7. Fill compressed air cylinders to the desired pressure, subsequently close filling valves slowly.
8. Close and vent all filling valves.
9. Disconnect all compressed air cylinders from filling valves.

## AUTO START FUNCTION

---

### Filling Procedure Automatic Operation



**Caution! Only fill cylinders which:**

- are marked with the test mark and the test stamp of the expert.
- have been hydro static tested (check last test date).
- are rated for the final pressure.
- are free from humidity.



**Note**

The unit shuts down when final pressure is reached. Thus, the unit always has to be restarted manually.

1. Turn selector switch to automatic mode.
2. Close all filling valves.
3. Connect closed compressed air cylinders.
4. Open cylinder valves.
5. Start compressor by pushing the ON button.
6. If the filling pressure increases, open the filling valves slowly.
7. Fill compressed air cylinders to the desired pressure, subsequently close filling valves slowly.
8. Close and vent all filling valves.
9. Disconnect all compressed air cylinders from filling valves.
10. If automatic operation is interrupted by:
  - pushing the OFF button
  - turning the selector switch
  - tripping the emergency shut-off switch
  - opening of the doors or the coverthe unit has to be restarted.



## AUTO START FUNCTION

---

### Spare Part List

Best.-Nr. / Order No.	Benennung	Description
000203	Druckschalter, G1/4" IG, PV 50 - 350 bar	Pressure Switch 50-350 bar
000738	Gerade Verschraubung	Straight Connection
000750	Verschraubung	Connection with fixed nut
004691	Schließer-Kontakt, Front	Closing contact (front)
005663	Einlegeschild	Insert Label
006859	Klemmrahmen (Schildträger)	Label holder

D

## AUTO START FUNCTION

### Spare Part List

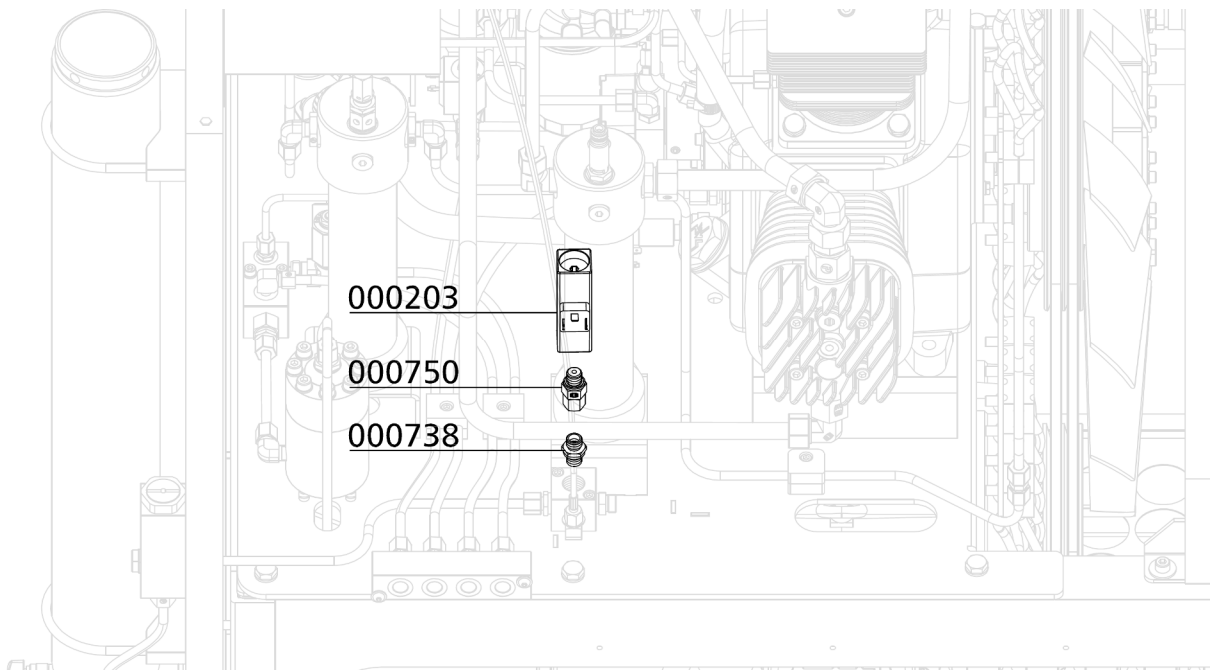

D

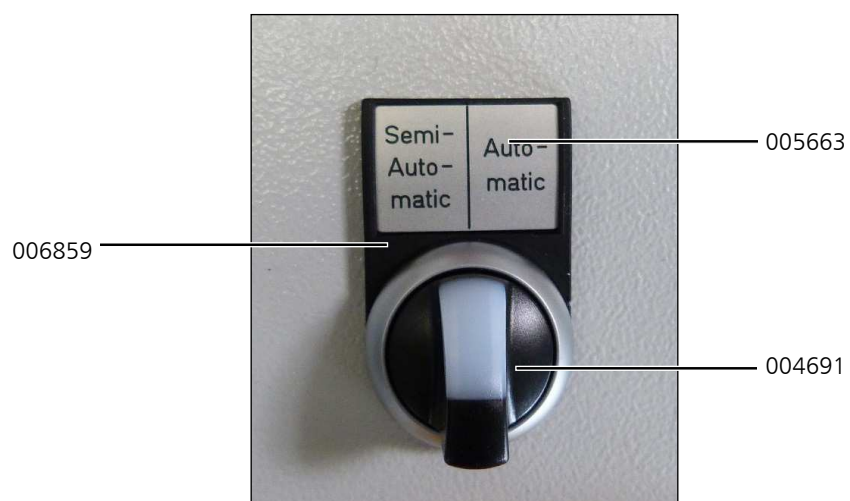



## FILLING DEVICE AT COMPRESSOR

C



## FILLING DEVICE AT COMPRESSOR

### Filling device at compressor

Allows the filling of cylinders directly at the compressor.

Up to six lever filing valves with filling hoses can be mounted at the front door.

The maximum pressure can be chosen between 200 bar and 300 bar.

A differentiation can be made by the colours of the gaiter at the lever filing valves:

Black: 200 bar

Red: 300 bar

Open the lever filing valve by moving the lever downwards. Stop or interrupt the filling procedure by moving the lever upwards. The corresponding filling hose and connector will be automatically vented at the same time.



Filling device at the compressor



#### Caution

Open lever filing valves only when the filling hose is connected to the cylinder and when it is secured against whipping around wildly.



## FILLING DEVICE AT COMPRESSOR

### Spare Part List

Best.-Nr. / Order No.	Benennung	Description
000750	Verschraubung	Connection with fixed nut
000751	Verschraubung	Connection incl nut&olive seal
000761	Winkelverschraubung	Elbow Connection
000783	Verschraubung	Straight Connection
001203	U-Scheibe A25	Washer A25
001435	Hochdruckschlauch	HP Hose
001443	Hochdruckschlauch	HP Hose
002299	Füllanschluss DIN 200 bar mit Handrad	Filling Connector - DIN200 bar
002300	Füllanschluss DIN 300 bar mit Handrad	Filling Connector - DIN300 bar
003858	Kipphebelventil / Kompressor 200 bar	Compr. lever fill. val 200 bar
003859	Kipphebelventil Kompressor ES 300 bar	Lever fill. valve / compressor
005637	Mutter (halbhoch) M24x1,5	Nut M24x1.5, zinc plated
008791	Hochdruck-Schnellkupplung	High Pressure Quick Coupling
008792	Hochdruck-Stecknippel	High Pressure Nipple
009827	Verschraubung	T-Connection
010080	Rohrleitung Ø8mm, komplett mit M.&S.	Pipe Ø8mm

C

# FILLING DEVICE AT COMPRESSOR

## Spare Part List

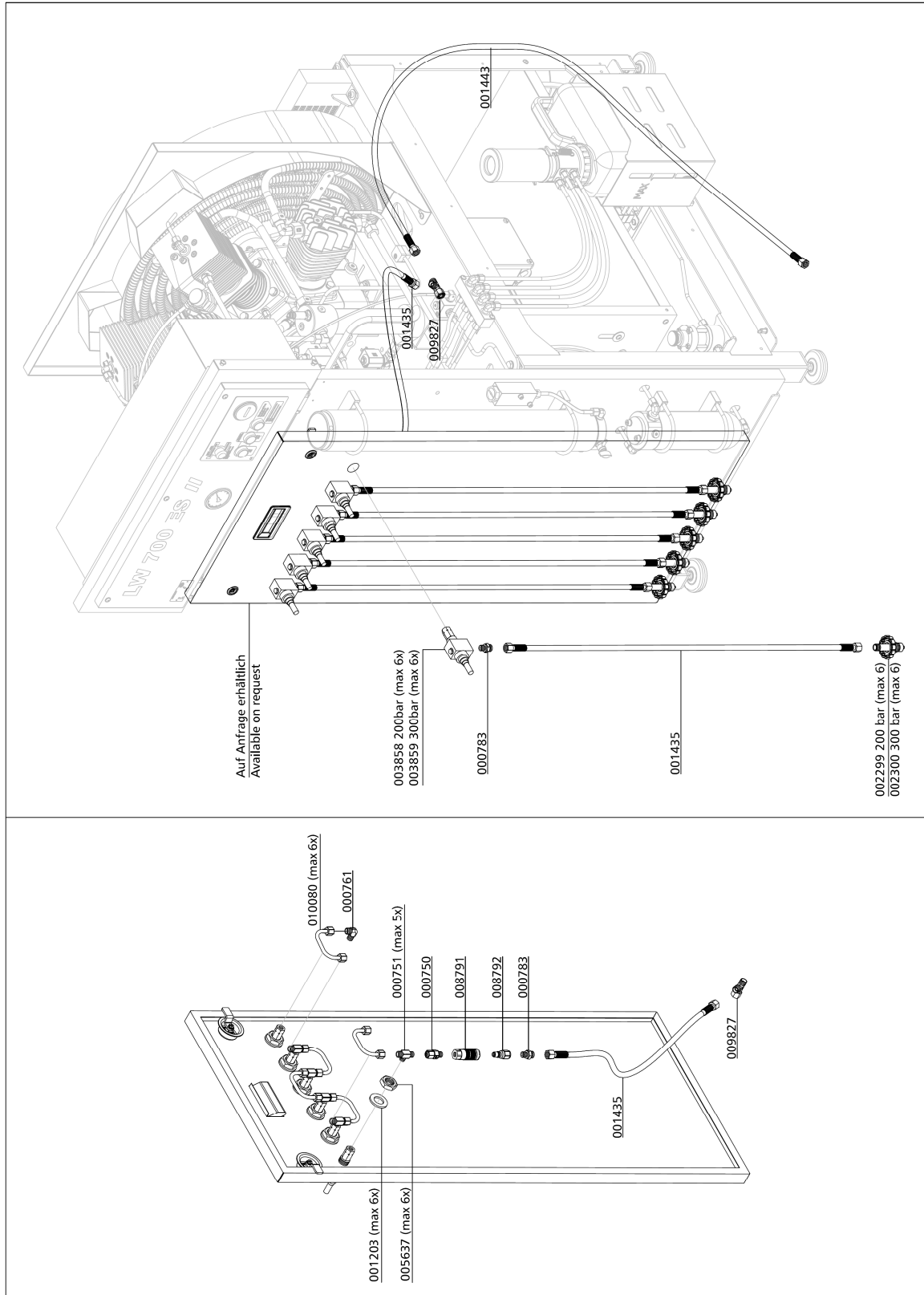

C



# INTEGRATED FILLING PANEL

C

## INTEGRATED FILLING PANEL

---

### Integrated Filling Panel

Option integrated filling panel gives the advantage that the compressor / panel unit is a fully working, compact filling station.

Having a single compact unit saves installation time and space.

Combined design helps to keep costs to a minimum.



C



## INTEGRATED FILLING PANEL

### Spare Part List

Best.-Nr. / Order No.	Benennung	Description
000102	Einschraubstutzen DIN Füllanschluss	Holder DIN Filling connector
000498	U-Scheibe A6	Washer A6
000628	Einfachschelle 1 x 8mm 1 Paar	Pipe Clamp 1x8mm 1pair PVC
000735	Verschraubung	Connection
000751	Verschraubung	Connection incl nut&olive seal
000761	Winkelverschraubung	Elbow Connection
000797	Verschraubung	Elbow Connection
000857	Reduzierung	Reducer with fixed nut
000899	Schottverschraubung 8L	Bulkhead Fitting 8L
000949	Flachkopfschraube	Pan Head Bolt
001027	Zylinderschraube	Allen Bolt
001156	Stopfmutter	Lock Nut M6
001157	Hutmutter	Domed Nut M6
001176	U-Scheibe A5	Washer A5
001387	Hochdruckschlauch	HP-Hose
001437	Hochdruckschlauch	HP Hose
001801	Aufsteckstutzen, Kompressorabdeckung	PVC Stud Plastic Cover
002299	Füllanschluss DIN 200 bar mit Handrad	Filling Connector - DIN200 bar
002300	Füllanschluss DIN 300 bar mit Handrad	Filling Connector - DIN300 bar
005439	Verschraubung Füllleisten	Connection for Filling Panels
005841	Linsenflanschschaube mit	Lens Head Screw
005842	Linsenflanschschaube mit	Lens Head Screw
006341	6-kant Blechschraube Ø5,5x13 DIN7976	Sheet Metal Screw
007695	Scharnier für Füllleiste ES Gehäuse	Hinge for Filling Panel ES
007698	Verschlussspanner Füllleiste ES Gehäuse	Clamp Hook ES Filling Panel
010099	Rohrleitung Ø8mm, komplett mit M.&S.	Pipe Ø8mm

C

# INTEGRATED FILLING PANEL

## Spare Part List

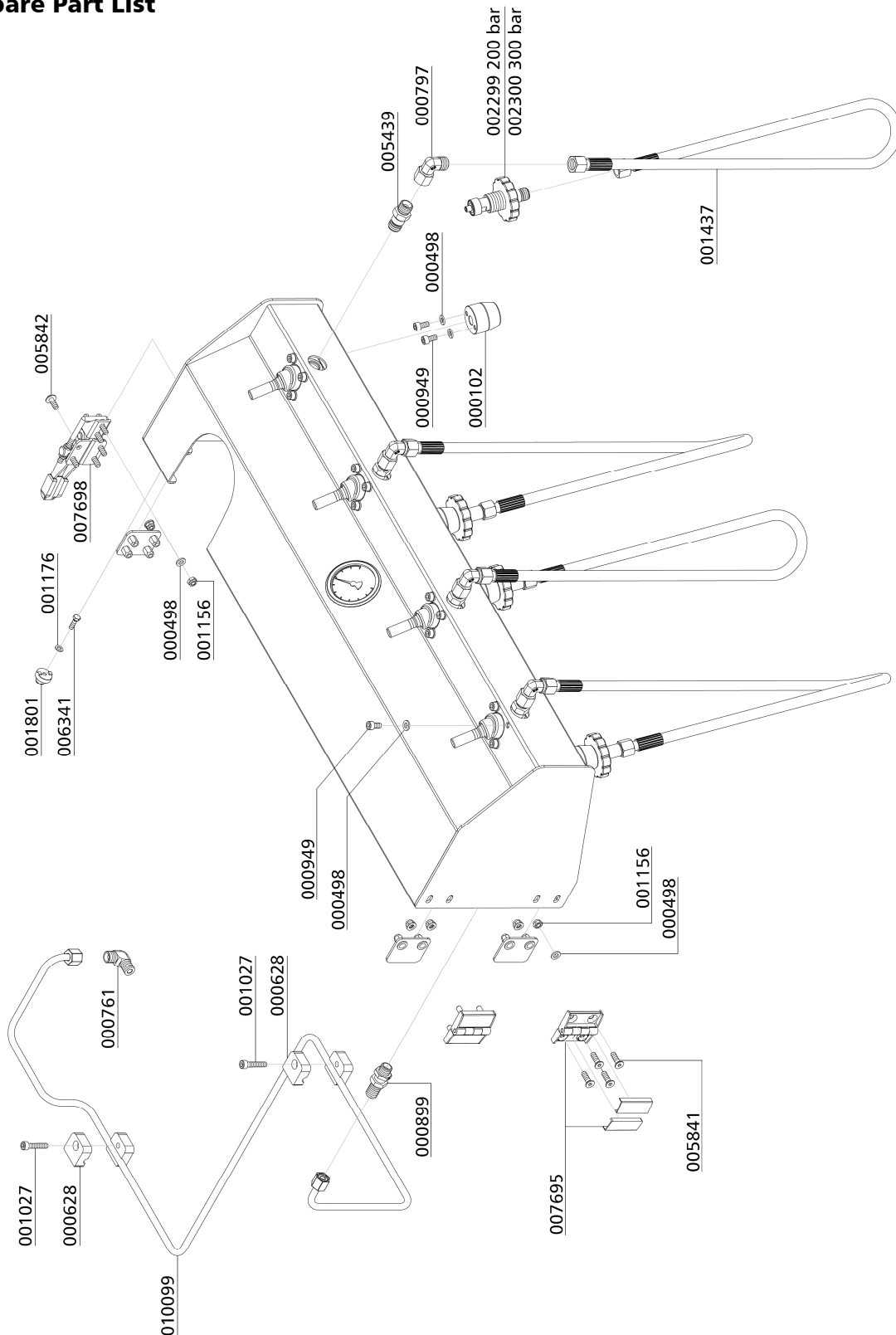

C

# INTEGRATED FILLING PANEL

## Spare Part List

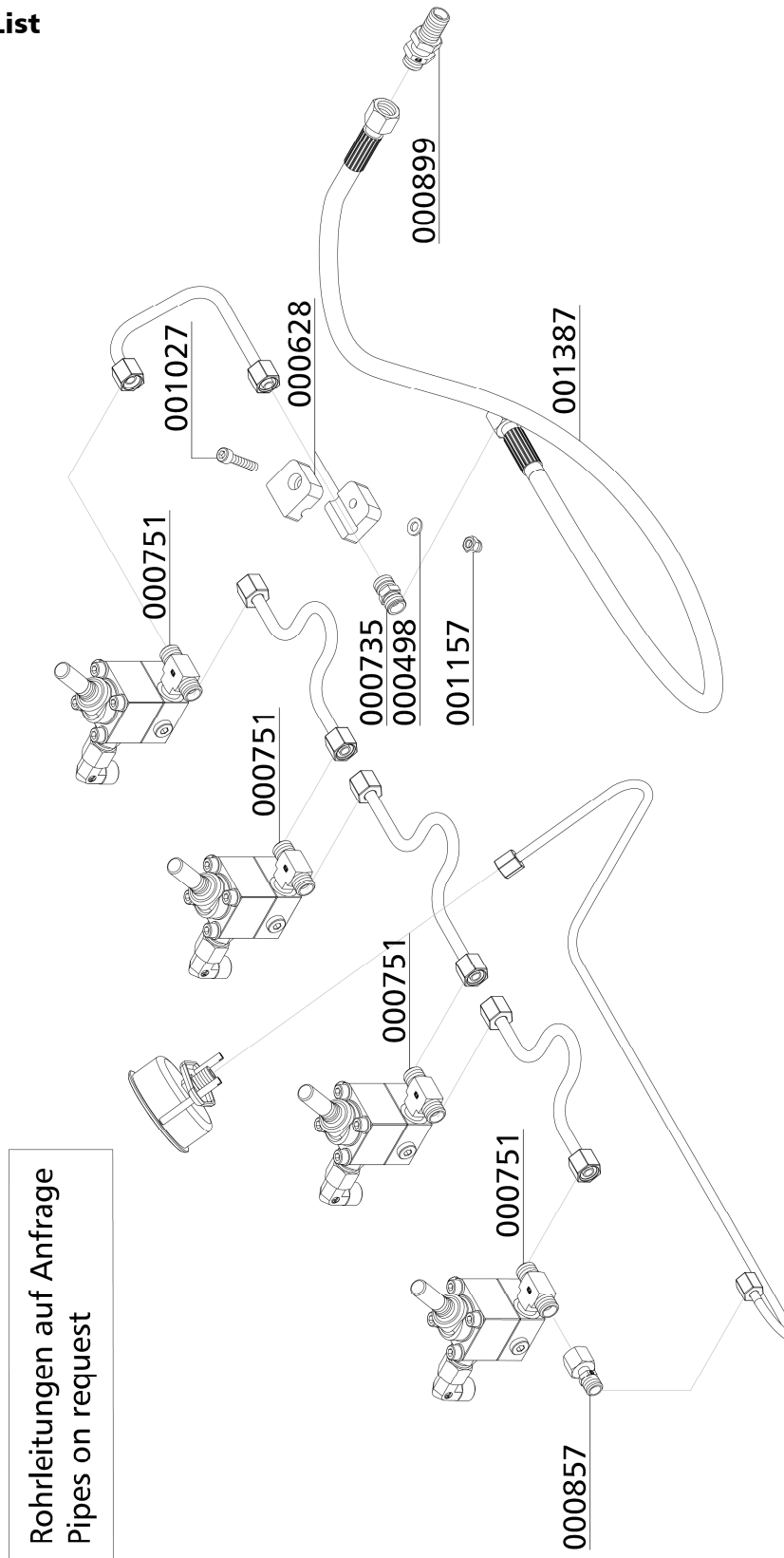

Rohrleitungen auf Anfrage  
Pipes on request







**200 / 300 BAR  
PARALLEL FILLING  
PRESSURE OPERATION**

**D**

## 200 / 300 BAR PARALLEL FILLING PRESSURE OPERATION

---

### 200 bar / 300 bar Parallel Filling Pressure Operation

This option allows the filling of 200 bar and 300 bar at the same time.

In this case, the compressor is equipped with a pressure reducer, a second final pressure safety valve and a second filling pressure gauge.

The handwheels or gaiters are colour-coded to allow an optical differentiation:

- 200 bar: black
- 300 bar: red

Furthermore, the corresponding filling pressures at the compressor are marked with labels.



DIN handwheels 200 bar and 300 bar



## 200 / 300 BAR PARALLEL FILLING PRESSURE OPERATION

### Spare Part List

Best.-Nr. / Order No.	Benennung	Description
000233	Sockel für Sicherheitsventil mit TÜV/CE	Base f. Safety Valve TÜV type
000498	U-Scheibe A6	Washer A6
000738	Gerade Verschraubung	Straight Connection
000747	Gerade Verschraubung	Straight Connection
000750	Verschraubung	Connection with fixed nut
000751	Verschraubung	Connection incl nut&olive seal
000761	Winkelverschraubung	Elbow Connection
000783	Verschraubung	Straight Connection
001044	Zylinderschraube	Allen Screw
001058	Zylinderschraube	Allen Bolt
001156	Stopfmutter	Lock Nut M6
001159	Stopfmutter	Lock Nut M8
001181	U-Scheibe A8	Washer A8
001203	U-Scheibe A25	Washer A25
001244	O-Ring	O-Ring, flange safety valve
001428	Druckminderer "High Flow" einstellbar	Pressure Reducer-Bolt version
001435	Hochdruckschlauch	HP Hose
001443	Hochdruckschlauch	HP Hose
002299	Füllanschluss DIN 200 bar mit Handrad	Filling Connector - DIN200 bar
002300	Füllanschluss DIN 300 bar mit Handrad	Filling Connector - DIN300 bar
003858	Kipphebelventil / Kompressor 200 bar	Compr. lever fill. val 200 bar
003859	Kipphebelventil Kompressor ES 300 bar	Lever fill. valve / compressor
004165	Halblech Sicherheitsventilsockel - std	Bracket for Safety valve base
004379	Verschraubung - Edelstahl	Connect.(inlet press. reducer)
005637	Mutter (halbhoch) M24x1,5	Nut M24x1.5, zinc plated
005841	Linsenflanschschraube mit Innensechskant	Lens Head Screw
008791	Hochdruck-Schnellkupplung	High Pressure Quick Coupling
008792	Hochdruck-Stecknippel	High Pressure Nipple
009827	Verschraubung	T-Connection

D

## 200 / 300 BAR PARALLEL FILLING PRESSURE OPERATION

### Spare Part List

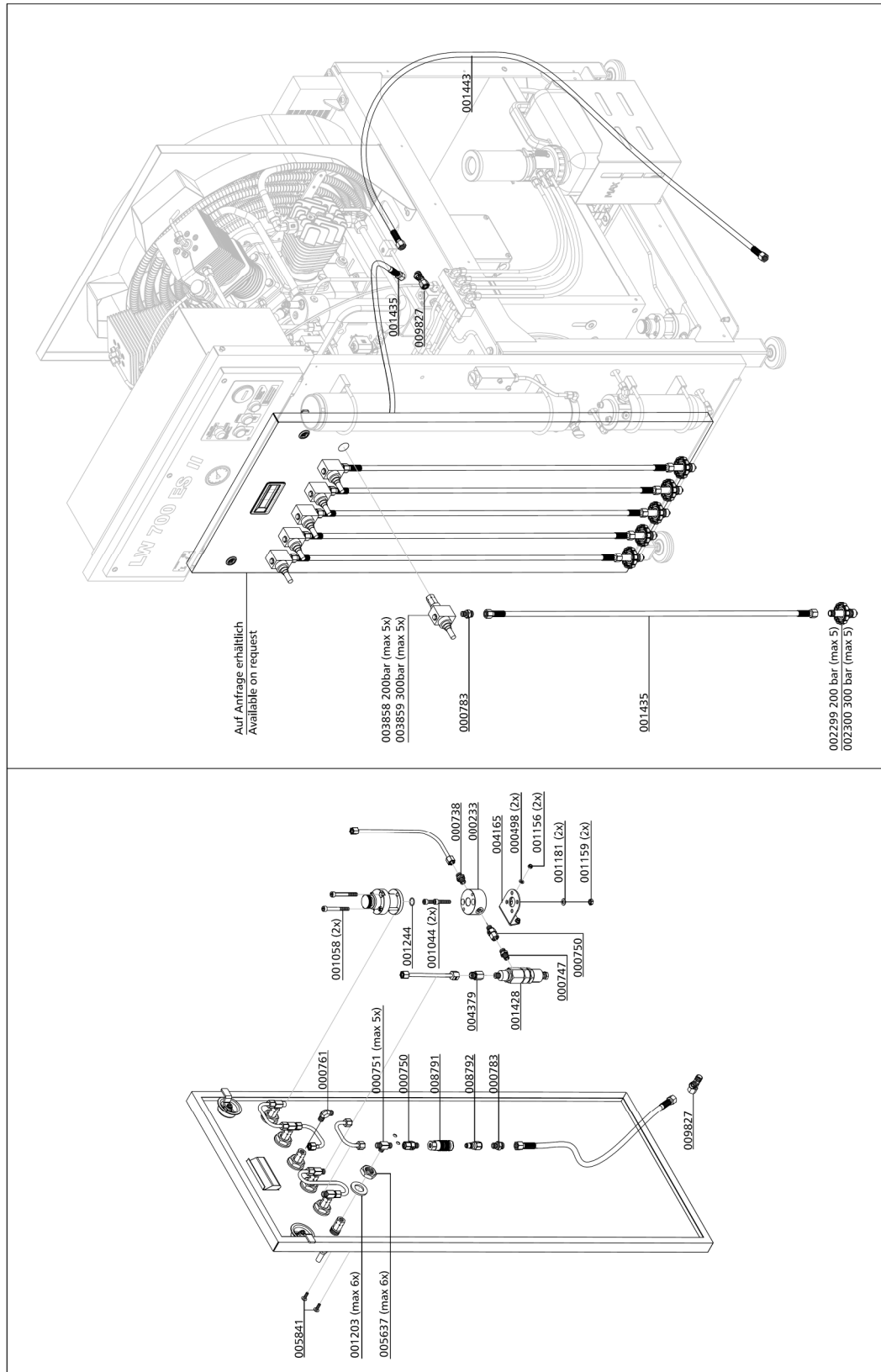

D



## 200 / 300 BAR PARALLEL FILLING PRESSURE OPERATION

### Spare Part List

Best.-Nr. / Order No.	Benennung	Description
000102	Einschraubstutzen DIN Füllanschluss G5/8	Holder DIN Filling connector
000498	U-Scheibe A6	Washer A6
000628	Einfachschelle 1 x 8mm 1 Paar	Pipe Clamp 1x8mm 1pair PVC
000663	Einbaumanometer mit Befestigungsbügel	Press. Gauge c/w fixing strap
000735	Verschraubung	Connection
000738	Gerade Verschraubung	Straight Connection
000747	Gerade Verschraubung	Straight Connection
000751	Verschraubung	Connection incl nut&olive seal
000758	Verschraubung	T-Connection with 1/4" radial
000761	Winkelverschraubung	Elbow Connection
000797	Verschraubung	Elbow Connection
000857	Reduzierung	Reducer with fixed nut
000899	Schottverschraubung 8L	Bulkhead Fitting 8L
000949	Flachkopfschraube	Pan Head Bolt
001027	Zylinderschraube	Allen Bolt
001040	Zylinderschraube	Allen Screw
001044	Zylinderschraube	Allen Screw
001156	Stopfmutter	Lock Nut M6
001157	Hutmutter	Domed Nut M6
001160	Hutmutter	Domed Nut M8
001176	U-Scheibe A5	Washer A5
001181	U-Scheibe A8	Washer A8
001387	Hochdruckschlauch	HP-Hose
001428	Druckminderer "High Flow" einstellbar	Pressure Reducer-Bolt version
001437	Hochdruckschlauch	HP Hose
001801	Aufsteckstutzen, Kompressorabdeckung	PVC Stud Plastic Cover
002299	Füllanschluss DIN 200 bar mit Handrad	Filling Connector - DIN200 bar
002300	Füllanschluss DIN 300 bar mit Handrad	Filling Connector - DIN300 bar
002506	Einbaumanometer 0-250bar	Pressure Gauge 0-250bar

D



## 200 / 300 BAR PARALLEL FILLING PRESSURE OPERATION

### Spare Part List

Best.-Nr. / Order No.	Benennung	Description
004379	Verschraubung - Edelstahl	Connect.(inlet press. reducer)
004925	Halterung für Druckminderer 001428	Bracket Pressure Reducer HF
005439	Verschraubung Fülleisten	Connection for Filling Panels
005841	Linsenflanschschraube mit Innensechskant	Lens Head Screw
005842	Linsenflanschschraube mit Innensechskant	Lens Head Screw
006341	6-kant Blechschraube Ø5,5x13 DIN7976	Sheet Metal Screw
007695	Scharnier für Fülleiste ES Gehäuse	Hinge for Filling Panel ES
007698	Verschlussspanner Fülleiste ES Gehäuse	Clamp Hook ES Filling Panel
009682	Verschraubung, P: 500 bar	T-Connection
010099	Rohrleitung Ø8mm, komplett mit M.&S.	Pipe Ø8mm

D

## 200 / 300 BAR PARALLEL FILLING PRESSURE OPERATION

### Spare Part List

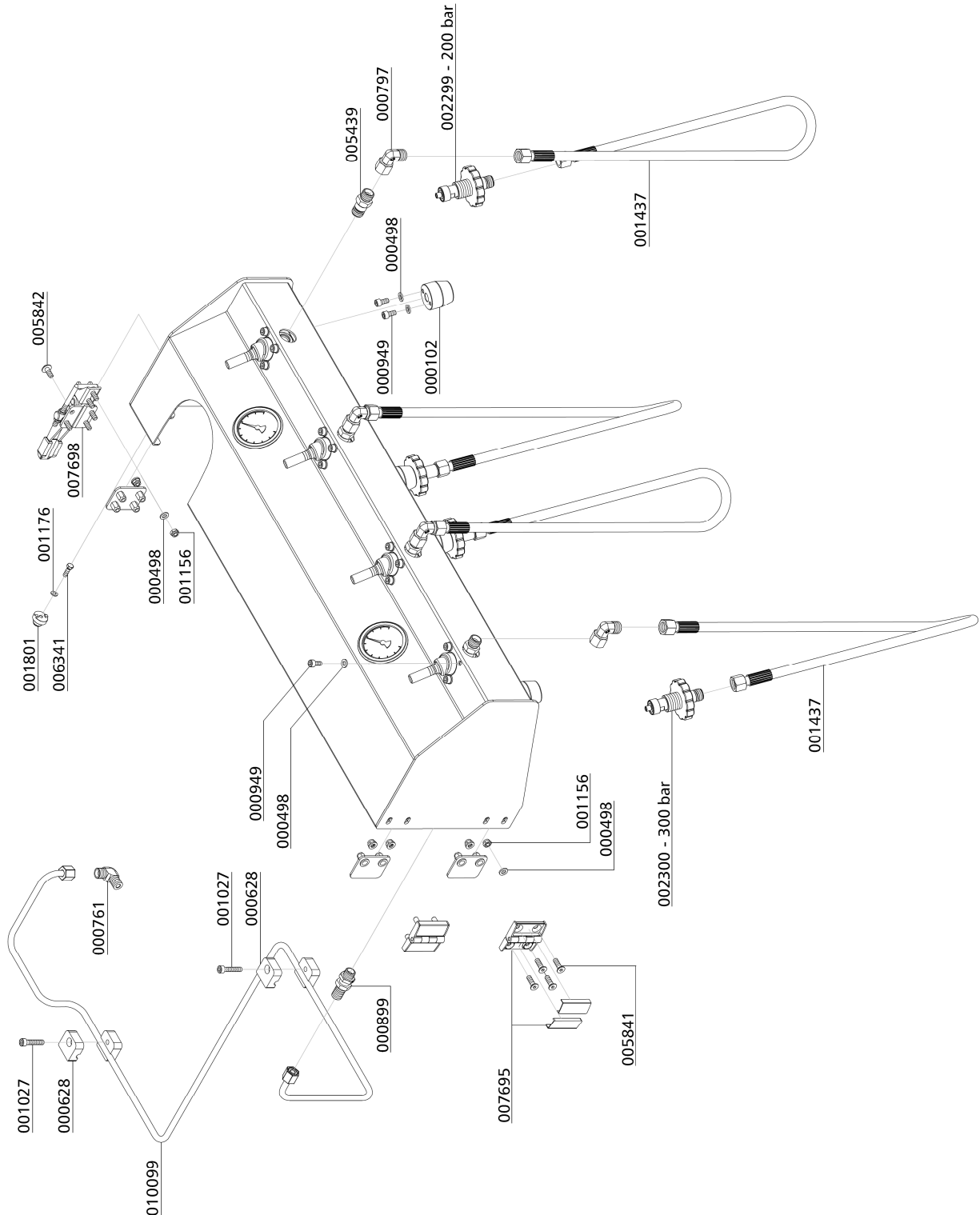

D







# OIL PRESSURE GAUGE

D

## OIL PRESSURE GAUGE

### Oil Pressure Gauge

The oil pressure gauge shows the compressor oil pressure during operation. Oil pressure gauge at operating temperature should display between:

- min. + 1,9 bar
- max. + 2,1 bar

#### If oil pressure value stays below the minimum value:

- Wrong compressor rotation direction (see rotation direction arrow)
- Oil level too low
- Oil pump sieve contaminated
- Oil intake pipe damaged / defective
- Oil temperature below +5 °C - lubrication not possible
- Oil temperature higher than +120 °C - oil viscosity too low
- Oil pump defective

#### If oil pressure value stays above the maximum value:

- Low oil temperature, between +5 °C and +10 °C (Should stay within the range of tolerance when operation temperature is reached)

### Oil pressure control

If oil pressure remains outside the range of tolerance, it can be adjusted at the oil pump.

Increasing oil pressure

- Turn adjusting screw clockwise

Reduce oil pressure

- Turn adjusting screw anti-clockwise

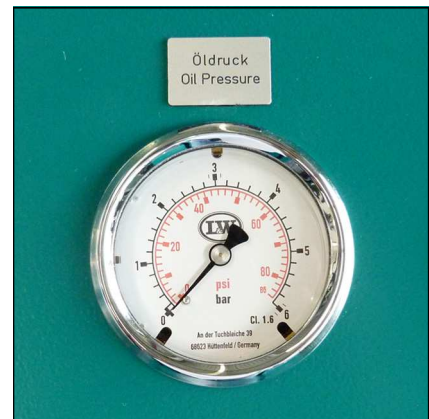

Oil Pressure Gauge

D



Adjusting the oil pressure



#### Warning

Only adjust the oil pressure at operating temperature!



## OIL PRESSURE GAUGE

### Spare Part Lists

Best.-Nr. / Order No.	Benennung	Description
000655	Einbaumanometer mit Befestigungsbügel	Press.Gauge, glycerine, brass
000660	Einbaumanometer mit Befestigungsbügel	Press. Gauge c/w fixing strap
000663	Einbaumanometer mit Befestigungsbügel	Press. Gauge c/w fixing strap
000710	Verschraubung	Connection w/o nut& olive seal
001447	Manometerschlauch 800mm	Pressure Gauge Hose
002507	Einbaumanometer glyzeringefüllt	Pressure Gauge 0-10bar
004169	Manometerschlauch 1000 mm	Pressure Gauge Hose 1000 mm
005539	Einbaumanometer glyzeringefüllt Messing	Press. Gauge c/w fixing strap
010936	Armaturenblech	Dashboard 5 x Ø63mm
010992	Armaturenblech	Dashboard 2 x Ø63mm

D

# OIL PRESSURE GAUGE

## Option: Oil Pressure Gauge

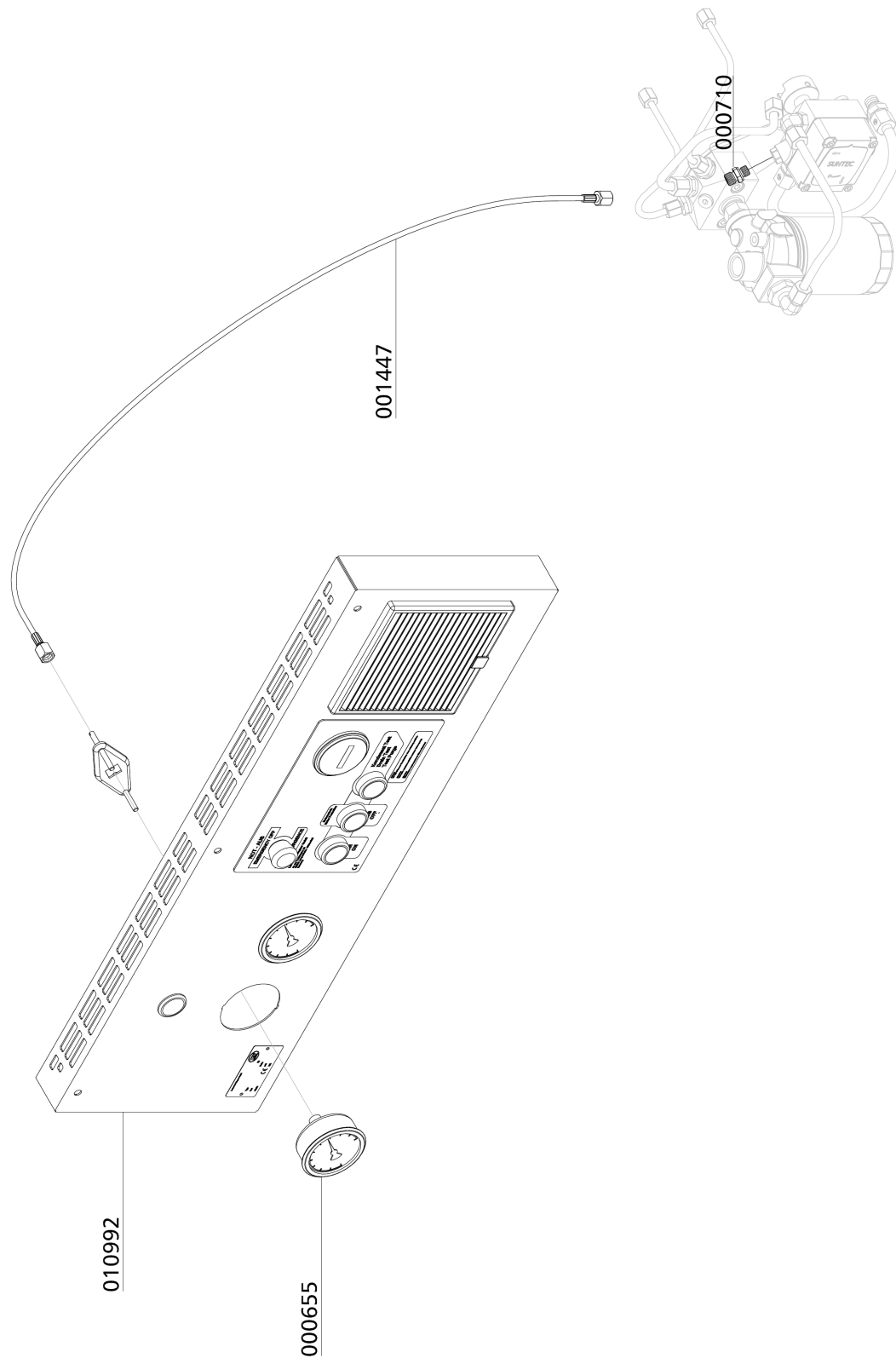

D

# OIL PRESSURE GAUGE

## Option: Oil Pressure Gauge and Interstage Pressure Gauge

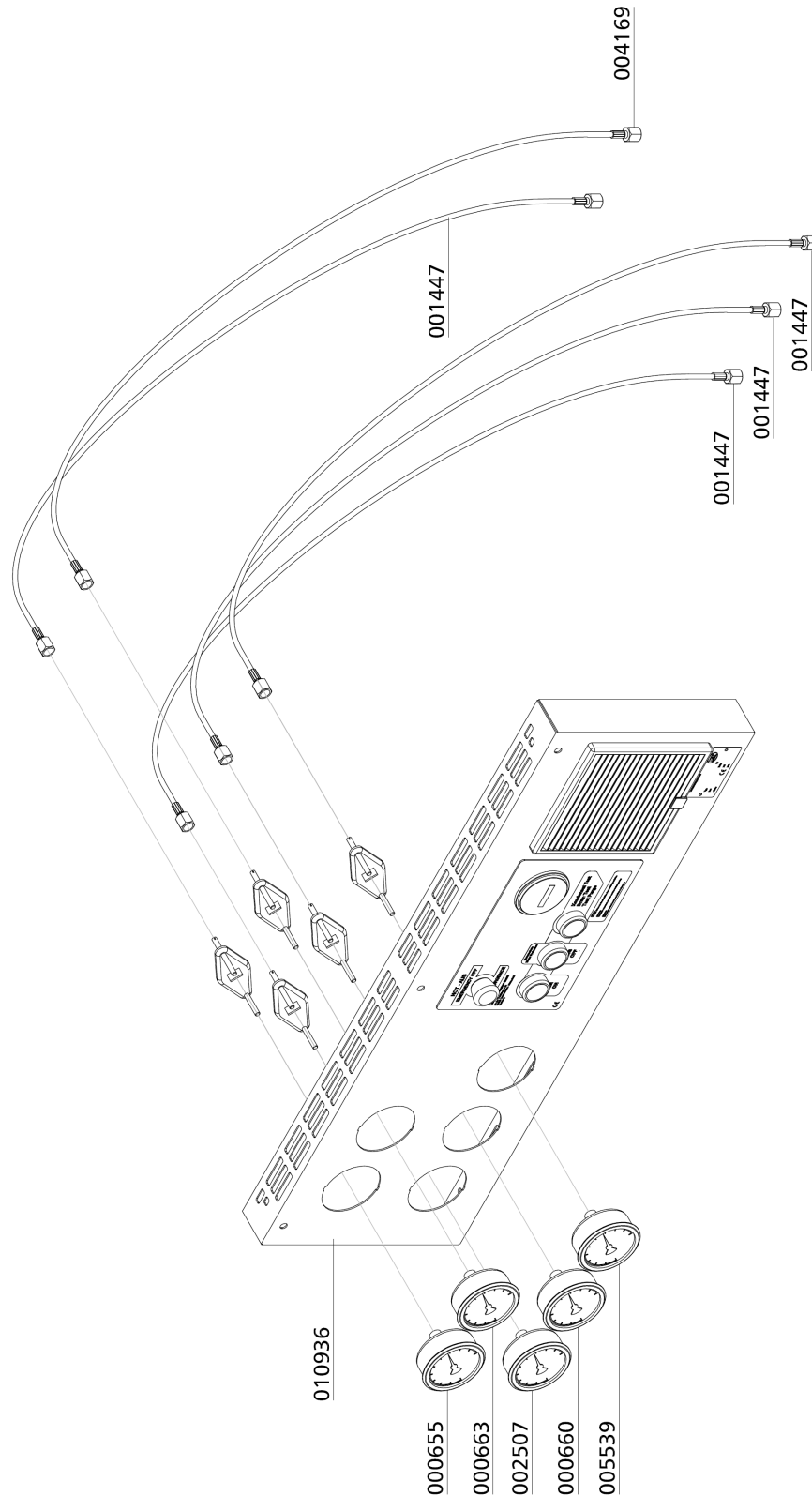



# INTERSTAGE PRESSURE GAUGE

D

## INTERSTAGE PRESSURE GAUGE

---

### Interstage Pressure Gauge

Each of the 4 pressure stages is monitored by it's own pressure gauge. This is helpful for troubleshooting and allows detecting faults at an early stage.

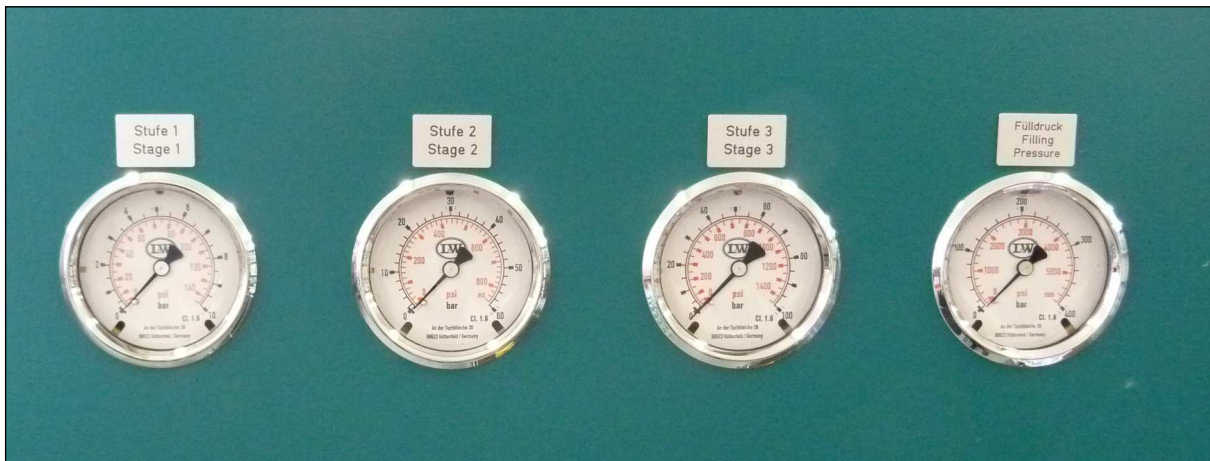

D

Indicated interstage pressure depends on actual final pressure.

The pressure gauges should show the following values at a final pressure of 200 bar:

- 1st stage: approx. 3.6 bar
- 2nd stage: approx. 15 bar
- 3rd stage: approx. 59 bar

The pressure gauges should show the following values at a final pressure of 300 bar:

- 1st stage: approx. 3.7 bar
- 2nd stage: approx. 16 bar
- 3rd stage: approx. 66 bar



## INTERSTAGE PRESSURE GAUGE

---

### Spare Part List

Best.-Nr. / Order No.	Benennung	Description
000660	Einbaumanometer mit Befestigungsbügel	Press. Gauge c/w fixing strap
000663	Einbaumanometer mit Befestigungsbügel	Press. Gauge c/w fixing strap
000710	Verschraubung	Connection w/o nut& olive seal
001447	Manometerschlauch 800mm	Pressure Gauge Hose
002507	Einbaumanometer glyzeringefüllt	Pressure Gauge 0-10bar
004169	Manometerschlauch 1000 mm	Pressure Gauge Hose 1000 mm
005539	Einbaumanometer glyzeringefüllt Messing	Press. Gauge c/w fixing strap
008995	Winkelverschraubung	Elbow Connection

D



# INTERSTAGE PRESSURE GAUGE

## Spare Part List

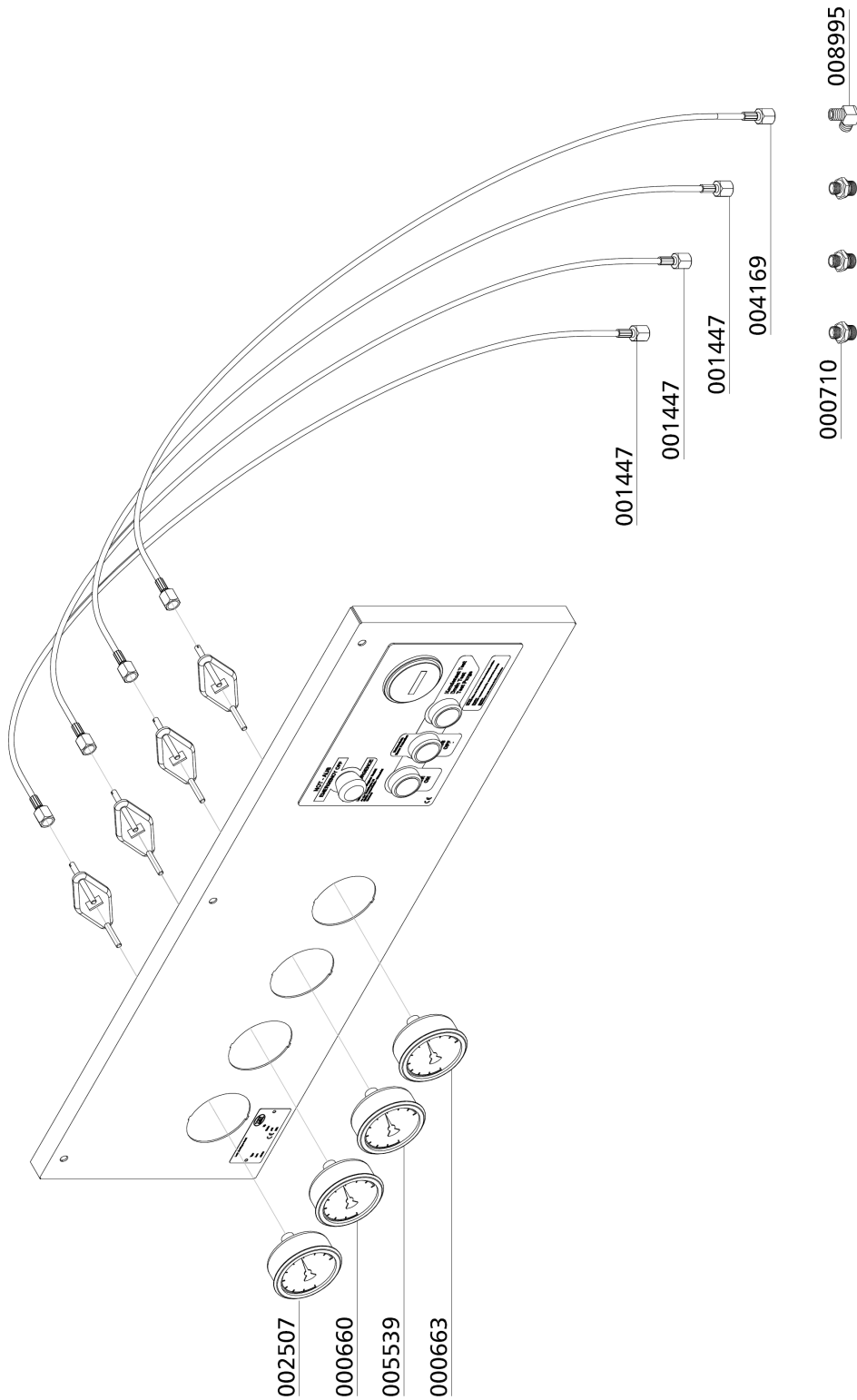

D



# OIL PRESSURE MONITORING

D

## OIL PRESSURE MONITORING

---

### Oil pressure monitoring

The oil pressure is maintained by a pressure switch during operation. The compressor automatically shuts off when oil pressure decreases below the minimum pressure of +0.5 bar. The red warning lamp "Oil Pressure Monitoring" lights up.

Possible causes of fault:

- Wrong compressor rotation direction  
(see rotation direction arrow)
- Oil level too low
- Oil pump sieve contaminated
- Oil intake pipe damaged / defective
- Oil temperature below +5 °C - lubrication not possible
- Oil temperature higher than +120 °C - oil viscosity too low
- Oil pump defective



Oil Pressure Monitoring

## OIL PRESSURE MONITORING

### Spare part lists

Best.-Nr. / Order No.	Benennung	Description
004701	Warnlampe	Warning Lamp
004703	Schild	Label
004704	Relais für Warnlampe	Relais for warning lamp
006859	Schildträger	Label holder

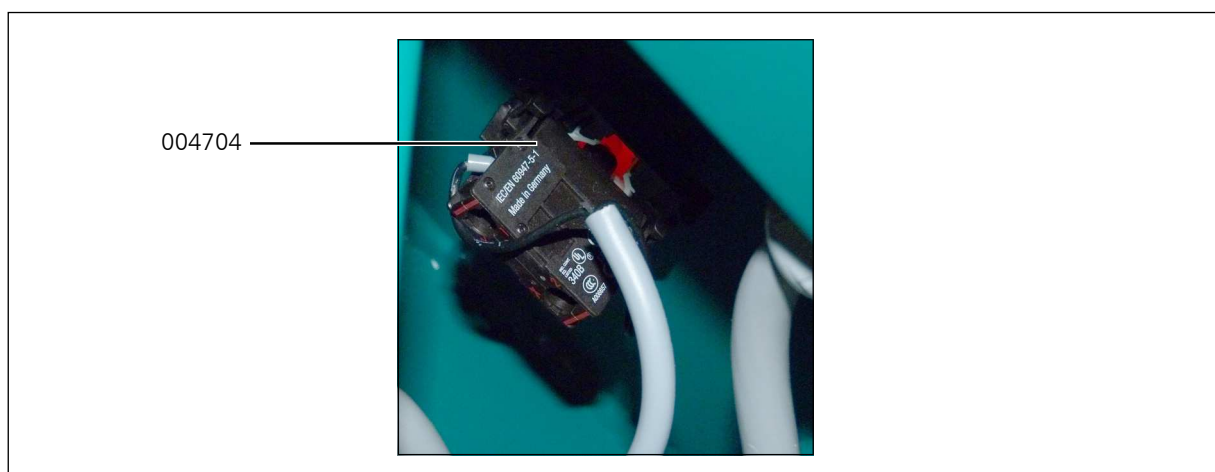



## OIL PRESSURE MONITORING

### Baugruppe: Öldrucküberwachung / Assembly: Oil Pressure Monitoring

Best.-Nr. / Order No.	Benennung	Description
000655	Einbaumanometer mit Befestigungsbügel	Press.Gauge, glycerine, brass
000710	Verschraubung	Connection w/o nut& olive seal
000720	Verschraubung	Connection with fixed nut
000732	Mutter	Union Nut 06L
001022	Zylinderschraube	Allen Bolt
001176	U-Scheibe A5	Washer A5
001447	Manometerschlauch 800mm	Pressure Gauge Hose
002395	Verschlusskegel 06mm	Locking cone 06mm
005261	Druckschalter inkl. Stecker	Oil Pressure Switch 0.2-2 bar
008995	Winkelverschraubung	Elbow Connection
009243	Öldruckleitung 6mm	Oil Suction Pipe
009460	Abstandhalter	Spacer

D

## OIL PRESSURE MONITORING

### Baugruppe: Öldrucküberwachung / Assembly: Oil Pressure Monitoring

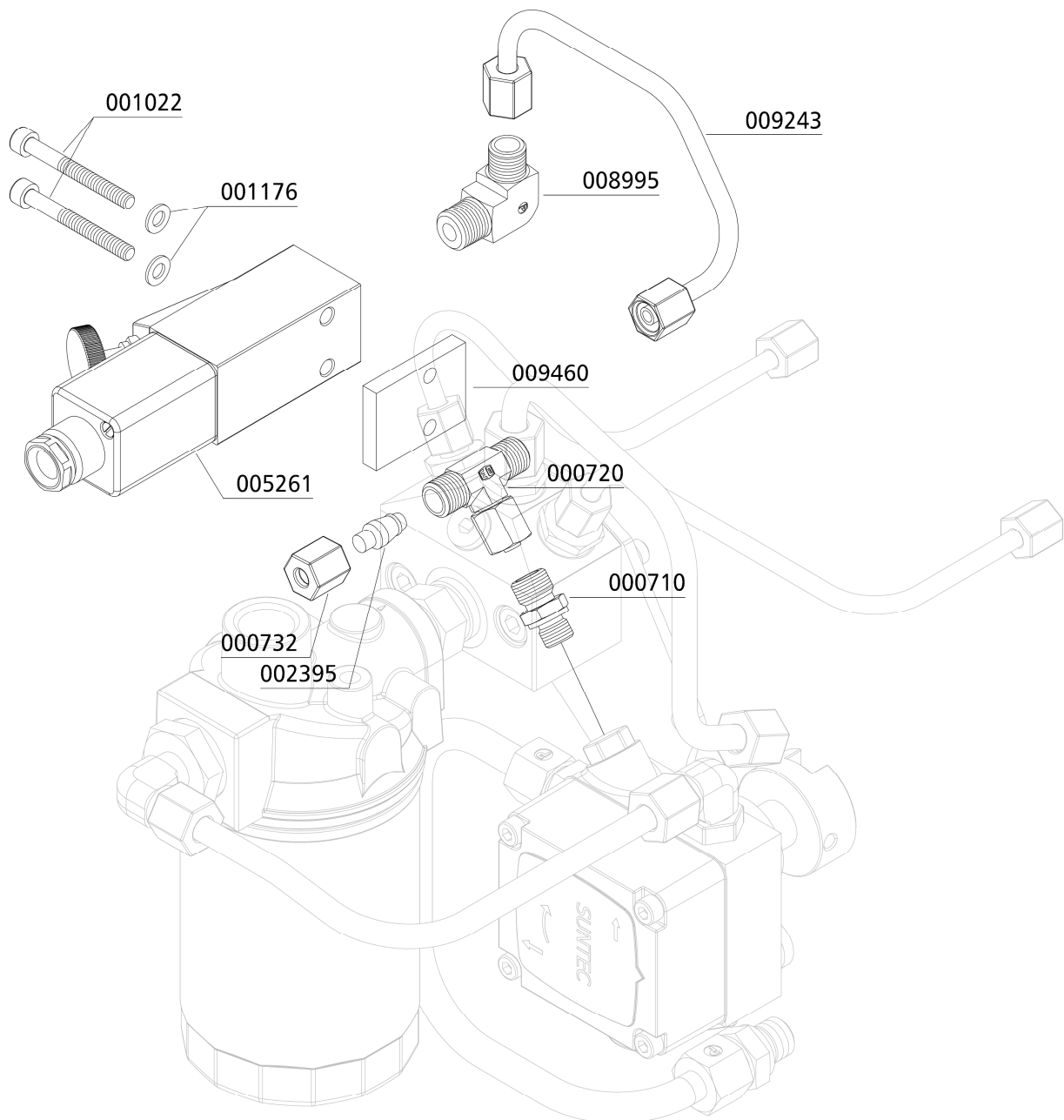

D

# OIL PRESSURE MONITORING

## Baugruppe: Öldrucküberwachung / Assembly: Oil Pressure Monitoring

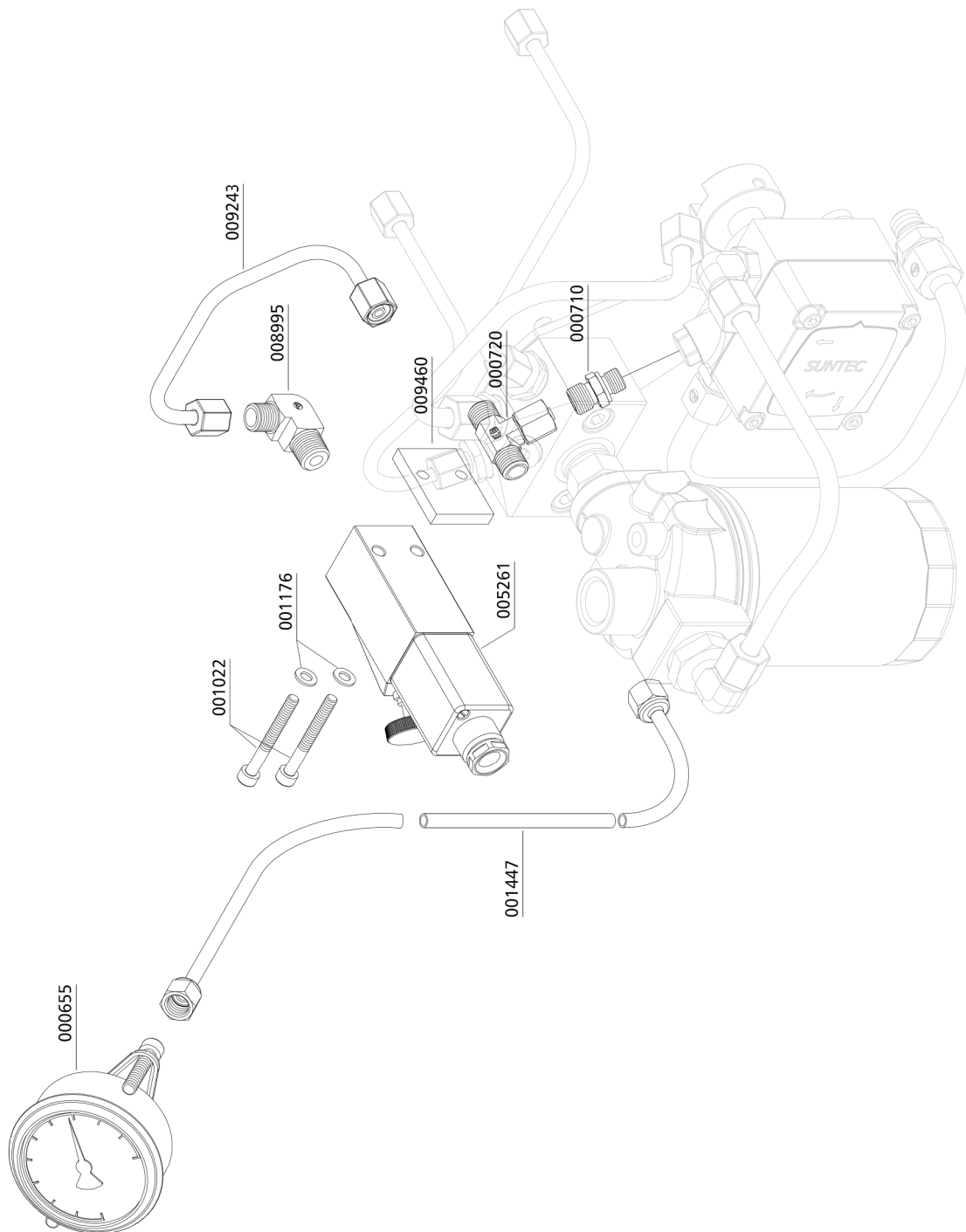

D



# CYLINDER HEAD TEMPERATURE MONITORING

D



## CYLINDER HEAD TEMPERATURE MONITORING

---

### Cylinder Head Temperature Monitoring

The cylinder head temperature is maintained by a temperature sensor at the cylinder head of the high pressure stage during operation. The compressor shuts off automatically when cylinder head temperature exceeds the maximum pressure of +140° C. The red warning lamp "Cylinder Head Temperature Monitoring" lights up.



Possible causes of fault:

- Ventilation of the compressor room is not sufficient
- Cooling air flow not sufficient
- Cooling pipes contaminated



#### Warning

Risk of burns!

Allow the unit to cool before beginning troubleshooting.

## CYLINDER HEAD TEMPERATURE MONITORING

### Spare Part Lists

Best.-Nr. / Order No.	Benennung	Description
004726	Display	Display
005585	Sensor	Sensor



D



# OIL TEMPERATURE MONITORING

D

## OIL TEMPERATURE MONITORING

### Oil Temperature Monitoring

Oil temperature monitoring

The oil temperature is maintained by a temperature sensor inside the compressor block during operation.

The compressor automatically shuts off when oil temperature exceeds the maximum pressure of +100 °C. The red warning lamp "Oil Temperature Monitoring" lights up.

Possible causes of fault:

- Ambient temperature too high
- Cooling air flow not sufficient
- Oil level too low
- Cooling pipes contaminated



Oil Pressure Monitoring

D



#### Warning

Risk of burns!

Allow the unit to cool before beginning troubleshooting.

## OIL TEMPERATURE MONITORING

### Spare Part List

Best.-Nr. / Order No.	Benennung	Description
004342	Display	Display
004730	Display und Sensor	Display and Sensor

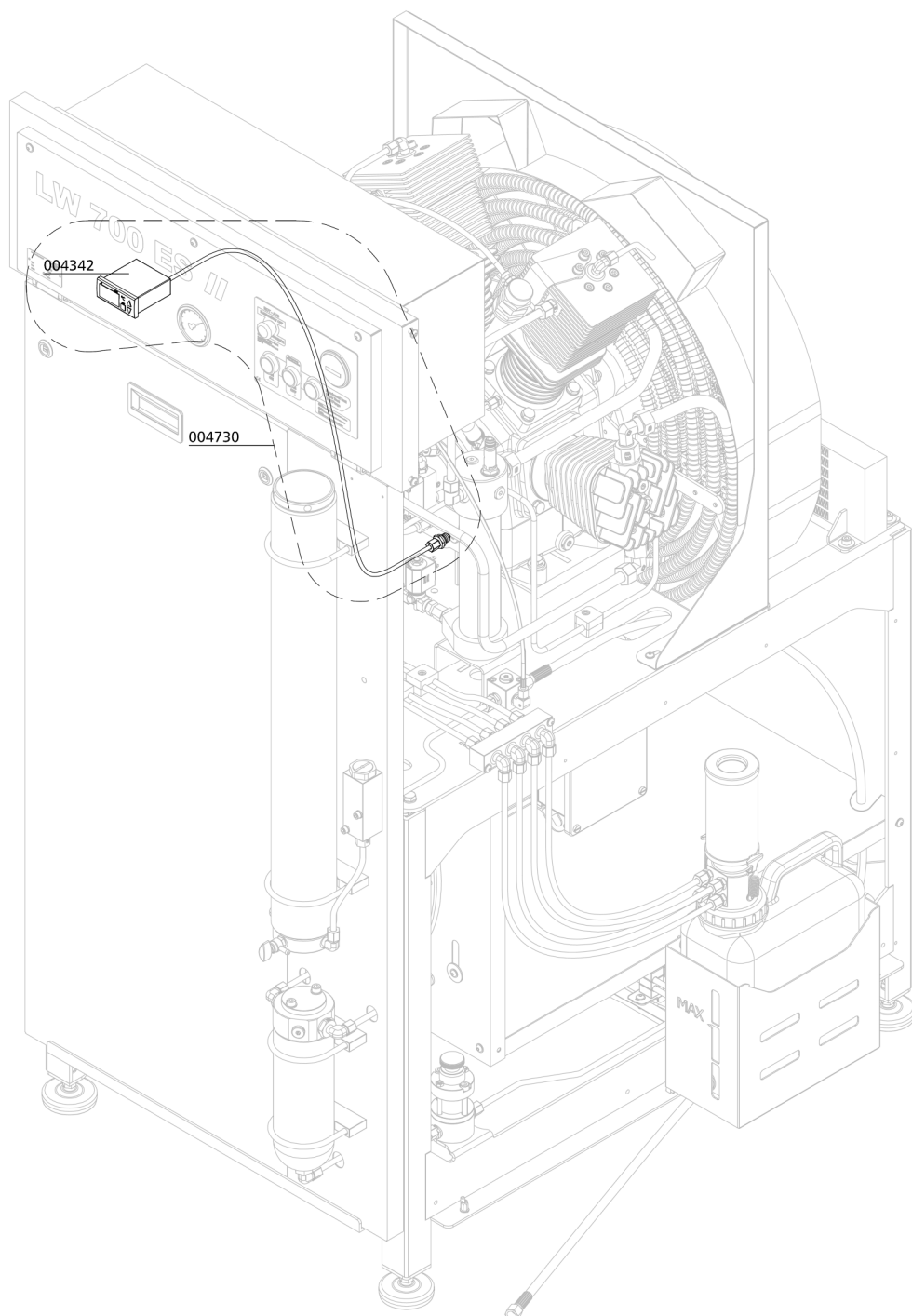

D



# PURACON FILTER MONITORING

D

## PURACON FILTER MONITORING

### Puracon Filter Monitoring

The usage of a humidity controller is the most reliable and economic method for filter monitoring.

#### Puracon Stationary PRO

Puracon Stationary PRO is the professional solution for humidity monitoring during the filling procedure. The PRO version provides separated sensor and display unit. The sensor is connected directly to the high-pressure line after the humidity filter and is linked to the display unit via a data cable.



Puracon Stationary PRO

#### Specifications

- Stainless steel sensor housing with screw joint and G $\frac{1}{4}$ " inlet and outlet
- Display unit (120 x 120 x 60 mm) for wall mounting with sensor cable (length: 2 m)
- Power supply cable (length: 1.2 m) with CE plug 230 V AC ~ 50/60 Hz (12/24V DC versions available)
- Digital LCD display with humidity display in mg/m $^3$  and error warnings
- Pressure compensation
- 3 monitoring LEDs, adjustable limits
- Language can be selected in German, English, French or Spanish
- Sensor cables with 5, 10, 15 or 30 m available for surcharge
- Approved up to 420 bar

#### Available Versions

- 230 V AC, 12 V DC, 24 V DC
- Ex with ATEX certification

Technical Data	Puracon Stationary PRO
Operating pressure	150 to 420 bar - adjustable pressure range
Power supply	240VAC / optional 12V or 24VDC
Connector	Sensor: G1/4 thread
Protection rating	IP64
Operating temperature	-10°C to +40°C



## PURACON FILTER MONITORING

---

### Spare Part List

Best.-Nr. / Order No.	Benennung	Description
000783	Verschraubung	Straight Connection
000799	Verschraubung	Connection with fixed nut
001443	Hochdruckschlauch	HP Hose
008713	Puracon Stationary Pro SP350, mit Sensor	Puracon SP350 Humidity Control
010993	Armaturenblech 1 Manometer und Puracon	Dash Panel - 1 Gauge & Puracon

D



# PURACON FILTER MONITORING

## Spare Part List

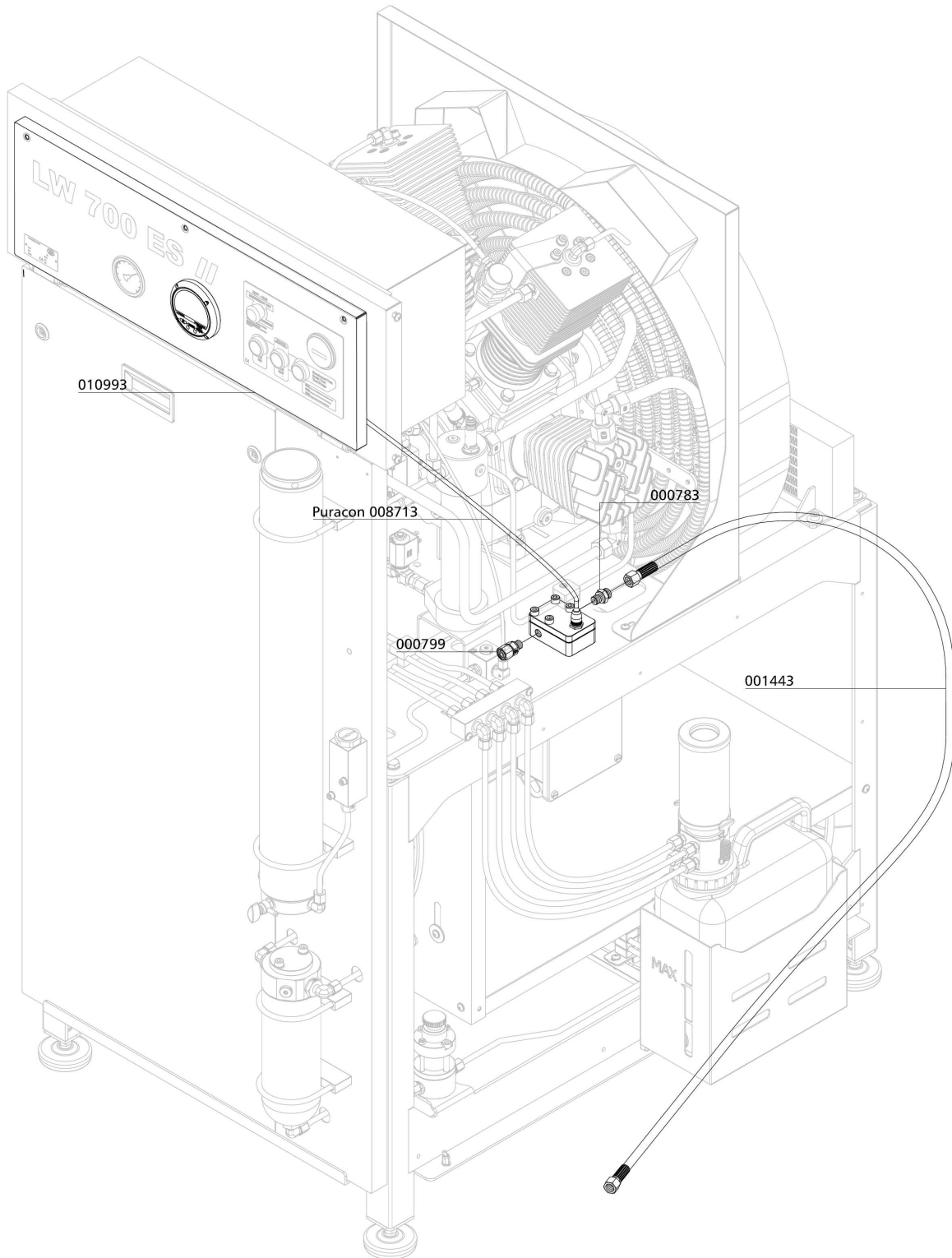

D



## BLOCK HEATING DEVICE

D

## BLOCK HEATING DEVICE

---

### Block Heating Device

Option "Block Heater" enables to run the compressor unit at temperatures below +5°C.

Block heater is controlled by a temperature sensor, which ensures that oil temperature is always at least +12°C. Above +12°C oil heater unit is deactivated.

If oil temperature is below +12°C (in case that power supply has been turned off), compressor can not be started until oil temperature has reached at least +12°C.



D

## BLOCK HEATING DEVICE

### Spare Part List

Best.-Nr. / Order No.	Benennung	Description
004342	Temperaturanzeige digital ohne Sensor	Temperature display, digital
004725	Heizstab Blockheizung	Heater bar, compressor block
004730	Temperaturanzeige digital inkl. Sensor	Temperature digital display

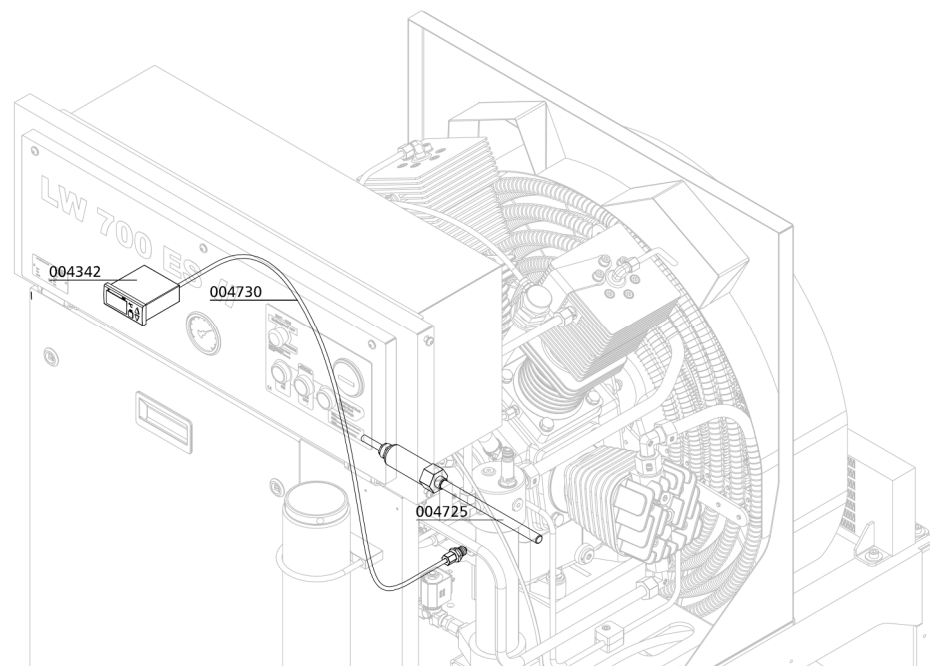
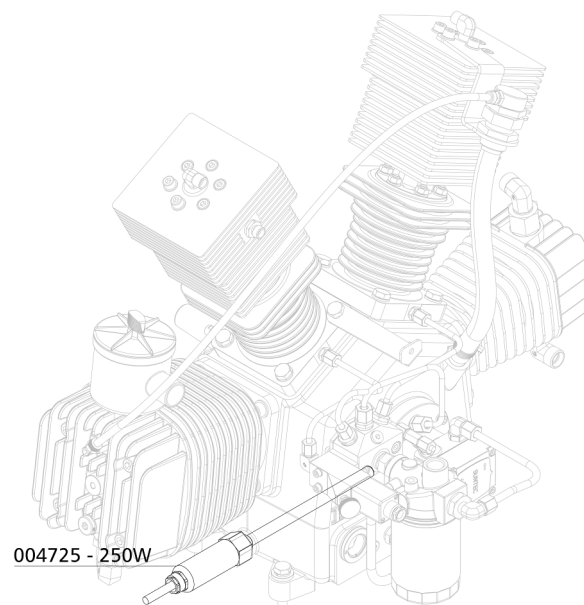



## 420 BAR VERSION

D



## 420 BAR VERSION

### Baugruppe: Verrohrung / Assembly: Pipework

Best.-Nr. / Order No.	Benennung	Description
000712	Verschraubung	Connection w/o nut& olive seal
000736	Verschraubung	Connection
000740	Verschraubung	Connection
000742	Verschraubung	Connection
000750	Verschraubung	Connection with fixed nut
000762	Verschraubung	Elbow Connection
000783	Verschraubung	Straight Connection
001443	Hochdruckschlauch	HP Hose
002283	Verschraubung	Elbow Connection w. fixed nut
003707	Rückschlagventil	Non-Return Valve
004169	Manometerschlauch 1000 mm	Pressure Gauge Hose 1000 mm
005043	Verschraubung	T-Connection
009951	Winkel-Schottverschraubung 8S	Elbow Bulkhead Fitting 8S
010125	Zusatzkühler, Endstufe, kompl.	Additional Cooler, Final Stage
010129	Rohrleitung Ø8mm, komplett mit M.&S.	Pipe Ø8mm
010130	Rohrleitung Ø8mm, komplett mit M.&S.	Pipe Ø8mm
010131	Rohrleitung Ø8mm, komplett mit M.&S.	Pipe Ø8mm
010132	Rohrleitung Ø8mm, komplett mit M.&S.	Pipe Ø8mm
010133	Rohrleitung Ø8mm, komplett mit M.&S.	Pipe Ø8mm
010134	Rohrleitung Ø8mm, komplett mit M.&S.	Pipe Ø8mm
010718	Rohrleitung Ø8mm, komplett mit M.&S.	Pipe Ø8mm
010719	Rohrleitung Ø8mm, komplett mit M.&S.	Pipe Ø8mm
010721	Rohrleitung Ø8mm, komplett mit M.&S.	Pipe Ø8mm
010722	Kühler 4. Stufe, mit M. & S.	Cooler 4th Stage LW 700
010980	Rohrleitung Ø8mm, komplett mit M.&S.	Pipe Ø8mm
010981	Rohrleitung Ø8mm, komplett mit M.&S.	Pipe Ø8mm

D

# 420 BAR VERSION

## Baugruppe: Verrohrung / Assembly: Pipework

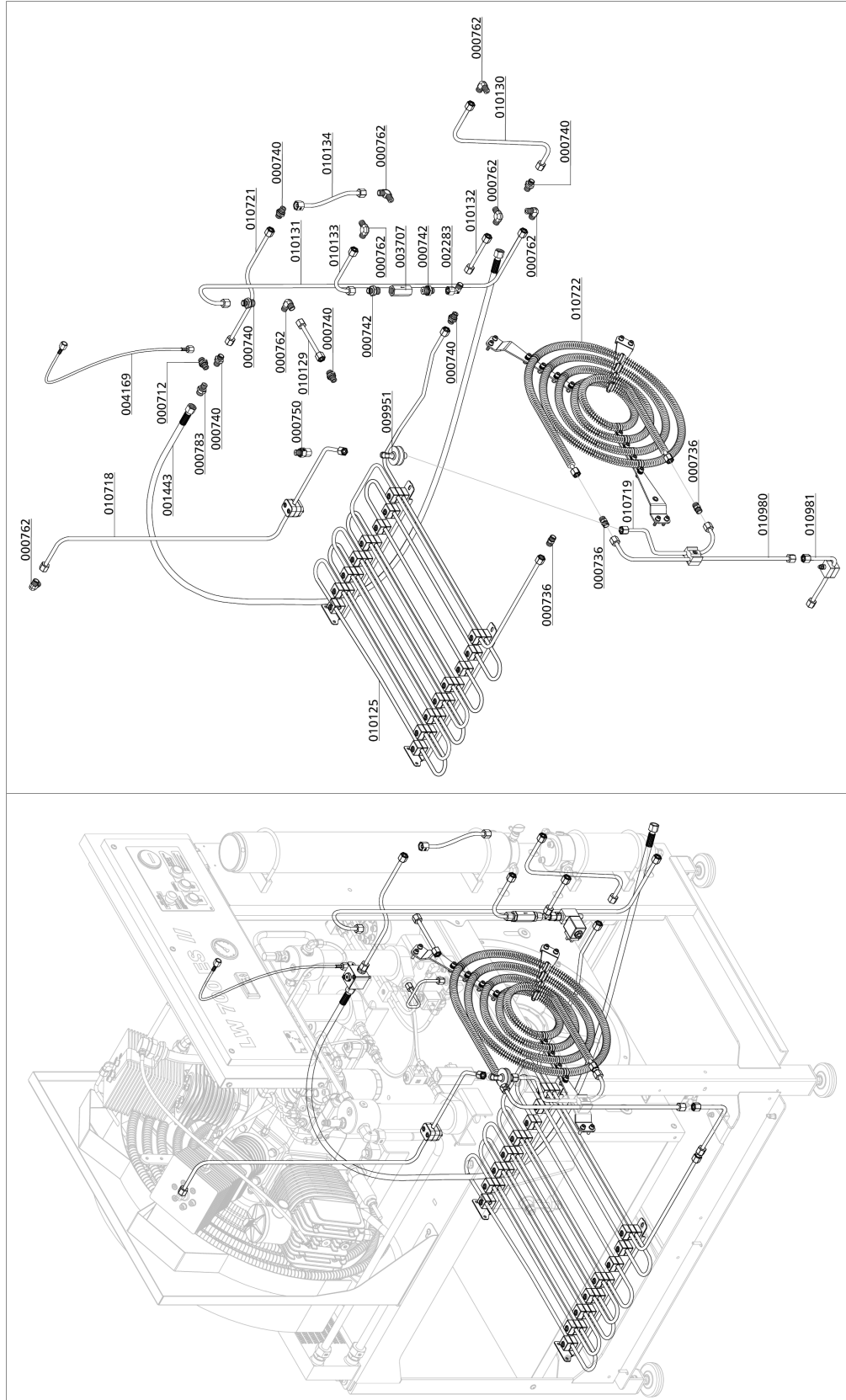

D



## 420 BAR VERSION

### Filtergehäuse 2,3 l 420 bar / Filter Housing 2.3 ltr 420 bar

Best.-Nr. / Order No.	Benennung	Description
000003	Filterpatrone 2,3 Liter	Filter Cartridge 2.3 ltr BA
000383	Messing Adapter für Filterpatrone	Brass Filter Adapter
000384	Düse für Filtergehäuse	Jet Filter Housing
000762	Verschraubung	Elbow Connection
000765	Schneidring 8 mm	Olive Seal 8 mm
000767	Mutter	Union Nut 08 S
001467	Filterpatrone, Aktivkohle, Entölung	Filter Cartr. Activ Carbon
001686	O-Ring, Druckbehälter	O-Ring, pressure vessel
001687	Stützring, für Druckbehälter	Retainer Ring, pressure vessel
002140	Filterschlüssel 1,7 & 2,3 Liter Behälter	Filter tool 1,7 & 2,3 Litre
002147	Haltebügel für Filtergehäuse (ES)	U-Clamp for filter housing ES
003017	Filtergehäuse, 2,3 ltr. 420 bar Eingang	Filter housing 2,3 ltr.
003077	Entwässerungsventil G1/4" AG, konisch	Drain Valve G1/4" male
005244	O-Ring	O-Ring

D



**420 BAR VERSION**

**Filtergehäuse 2,3 l 420 bar / Filter Housing 2.3 ltr 420 bar**

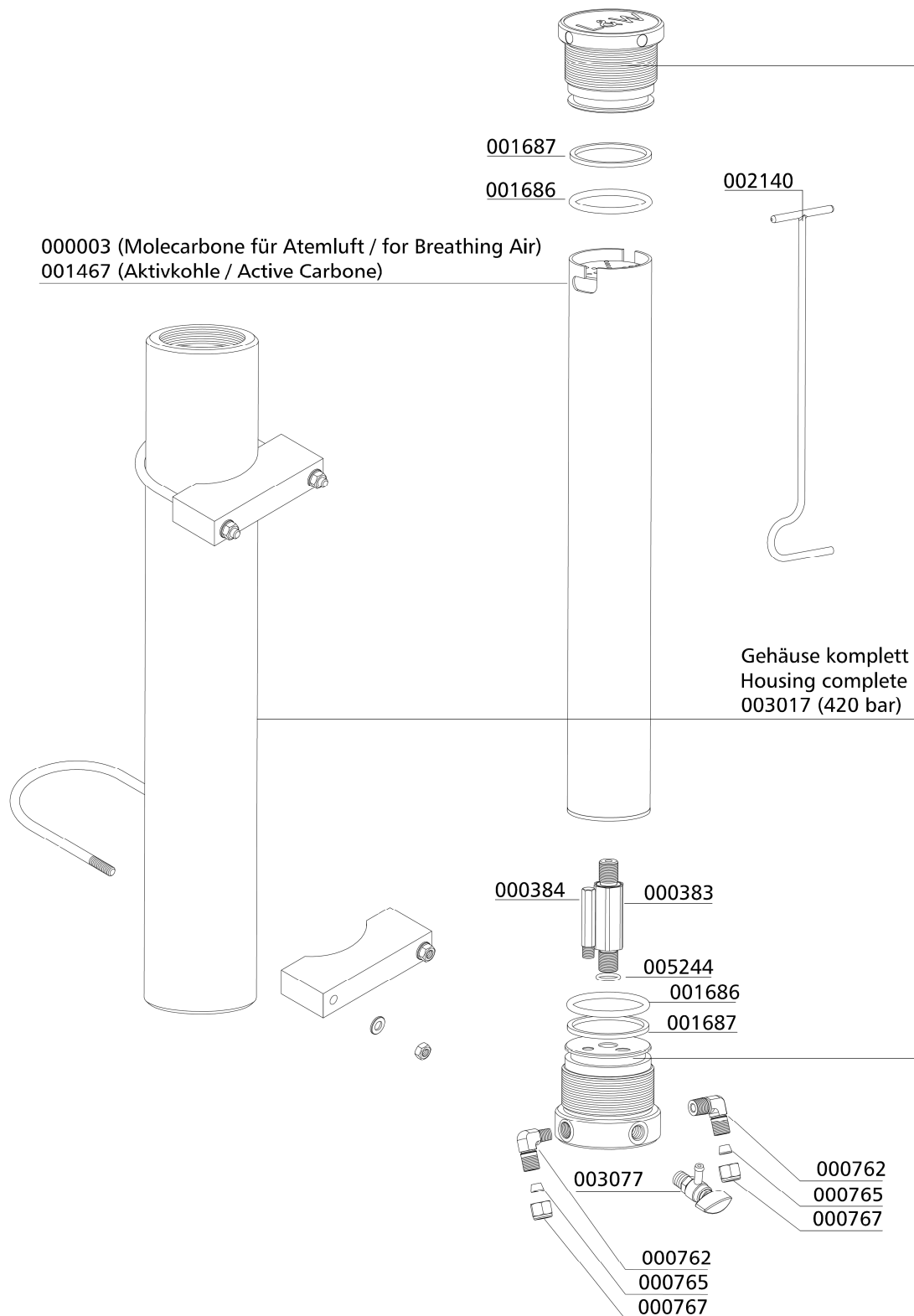

**D**



## 420 BAR VERSION

---

### Druckschalter 420 bar / Pressure Switch 420 bar

Best.-Nr. / Order No.	Benennung	Description
000750	Verschraubung mit fester Mutter, EGE 08 PSR-ED / G1/4	Connection with fixed nut, EGE 08 PSR-ED / G1/4
000754	Verschraubung T08S	Connection
001512	Druckschalter 50-600 bar, 250 Volt AC G1/4"	Pressure Switch 50-600 bar, 250 Volt AC G1/4"
002283	Verschraubung EW08S	Elbow Connection w. fixed nut

D

**420 BAR VERSION**

---

**Druckschalter 420 bar / Pressure Switch 420 bar**

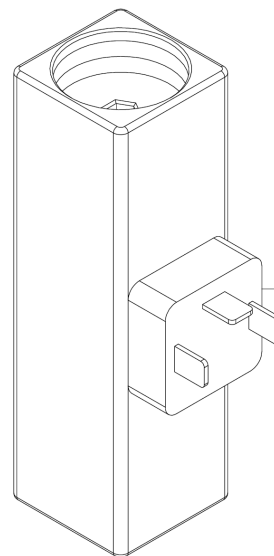

001512

D

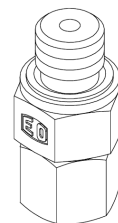

000750

000754

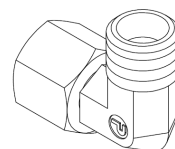
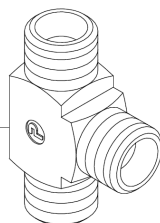

002283



## 420 BAR VERSION

### Sicherheitsventil 420 bar / Safety Valve 420 bar

Best.-Nr. / Order No.	Benennung	Description
000233	Sockel für Sicherheitsventil mit TÜV/CE	Base f. Safety Valve TÜV/CE type
000740	Verschraubung GE08SREDOMDA3C	Connection GE08SREDOMDA3C
000765	Schneidring PSR 08 LX	Olive Seal PSR 08 LX
000767	Mutter 8S M16x1,5 IG	Nut 8S M16x1,5 IG
000783	Verschraubung GE10L - R1/4"	Straight Connection GE10L - R1/4"
001041	Zylinderschraube M8x25mm DIN912 8.8 ZN	Allen Bolt M8x25mm DIN912 8.8 ZN
001044	Zylinderschraube M8x40mm DIN912 8.8 ZN	Allen Bolt M8x40mm DIN912 8.8 ZN
001158	Mutter	Nut
001181	U-Scheibe	Washer
001244	O-Ring, Flansch Sicherheitsventil	O-Ring, Flange Safety Valve
005233	Adapter Stecksockel auf G1/2" IG, Edelstahl	Adapter plug base to 1/2" female, S/S
005286	Cu-Dichtring 21x28x1,5 mm DIN 7603A	Copper Seal Ring 21x28x1.5 mm DIN 7603A
006376	Sicherheitsventil 420 bar, ohne TÜV, G1/2"AG - G3/4"IG	Safety Valve 420 bar, without TÜV, G1/2" male - G3/4" female
006919	Sicherheitsventil 420 bar, inkl. TÜV, G1/2"AG - G3/4"IG, Pressluft	Safety Valve 420 bar, incl. TÜV, G1/2" male - G3/4" female, BA
009601	U-Scheibe DIN 1441 ST ZN 8	Washer DIN 1441 ST ZN 8

D

## 420 BAR VERSION

### Sicherheitsventil 420 bar / Safety Valve 420 bar

Druck / Pressure: 420 bar	SV-Ventil mit CE-Prüfung / Safety Valves with CE-Approval: 006376	SV-Ventil mit TÜV-Prüfung / Safety Valves with TÜV-Approval: 006919
---------------------------------	---	---

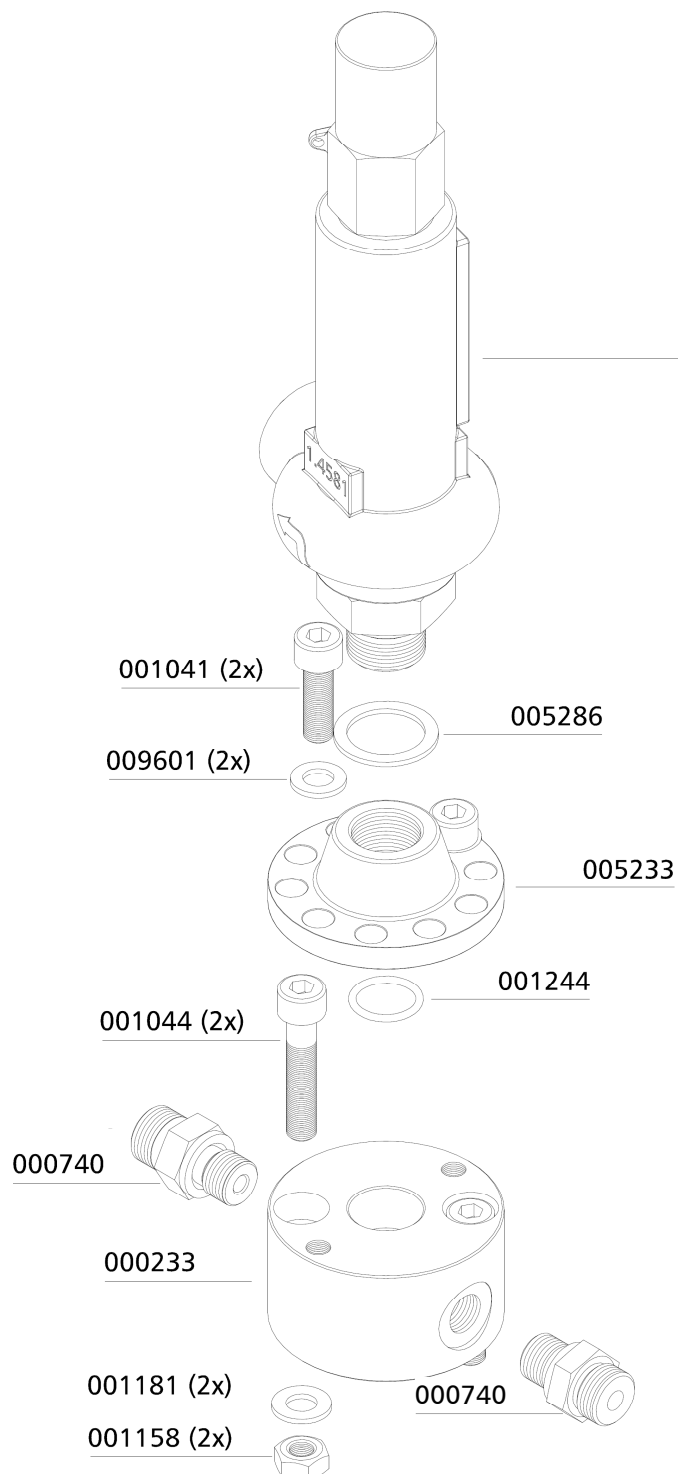

D



# PHASE MONITORING

D

## PHASE MONITORING

---

### Phase Monitoring

With this option the direction of rotation is controlled by a phase monitoring system during the operation.

If the compressor is incorrectly connected the power supply does not allow to start the machine. In this case the red warning lamp will indicate the problem. A changing of the direction of rotation is inevitable then.

Another advantage is the control during the operation. In case of dissolving a phase, the compressor will shut-down automatically. The red warning lamp will indicate to this after shut-down directly.



Phase Monitoring



## PHASE MONITORING

---

### Spare Part List

Best.-Nr. / Order No.	Benennung	Description
004701	Warnlampe	Warning Lamp
004704	Relais für Warnlampe	Relais for warning lamp
006859	Schildträger	Label holder
008551	Einlegeschild Phasenüberwachung	Label Phase Control

D



## PHASE MONITORING

### Spare Part List

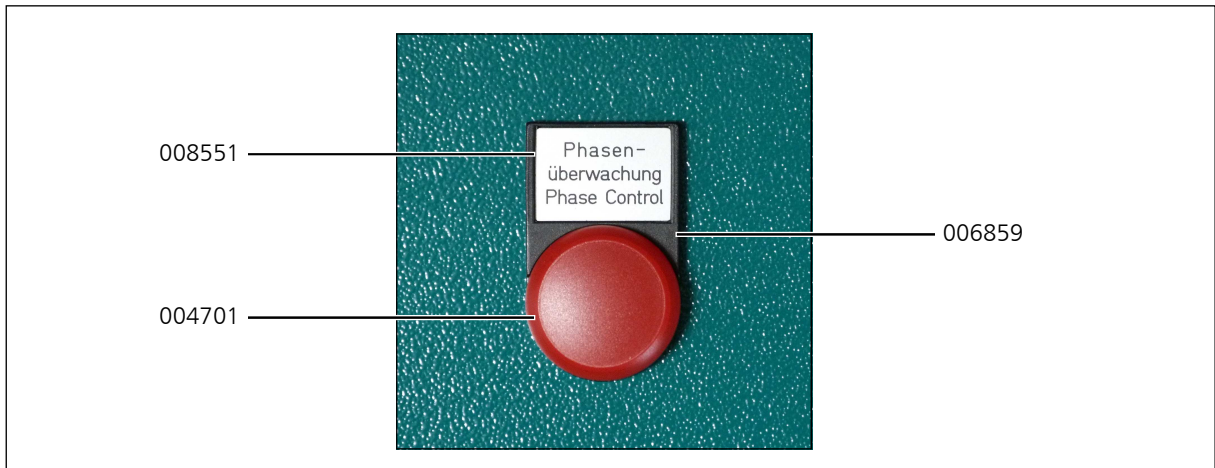

D

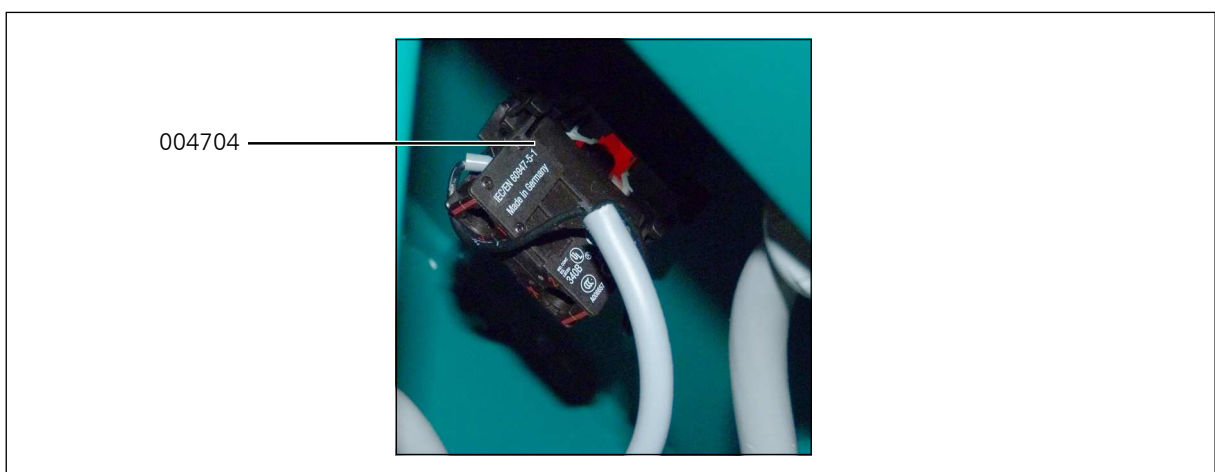



## SPECIAL VOLTAGE

D



## SPECIAL VOLTAGE

---

### Special Voltage

The compressor unit can be equipped with different voltages and frequencies. The power of the compressor motor can be lower and higher based on the needed requirement.

The following table will show possible voltages and frequencies. The associated data sheets can be found in the following pages.



#### Note

If your required data sheet is missing, please contact us directly under [service@lw-compressors.com](mailto:service@lw-compressors.com).

D

### Possible special voltages and frequencies

Voltage	Frequency
440 V	50 Hz
460 V	60 Hz
230 V	50 Hz
265 V	60 Hz

## SPECIAL VOLTAGE

### Technical Data



Technical Data	LW 700 ES II
Flow Rate [l/min]:	700
Max. Operating Pressure [bar]:	420
RPM [min <sup>-1</sup> ]:	1,400
Number of Pressure Stages:	4
Cylinder Bore 1st Stage [mm]:	Ø 105
Cylinder Bore 2nd Stage [mm]:	Ø 50
Cylinder Bore 3rd Stage [mm]:	Ø 25
Cylinder Bore 4th Stage [mm]:	Ø 14
Medium:	Compressed Air / Breathing Air
Intake Pressure:	atmospheric
Oil Pressure (at operating temperature) [bar]:	+2.0 (±0.1)
Oil Capacity [l]:	2.9
Intake Temperature [°C]:	0 < +45
Ambient Temperature [°C]:	+5 < +45
Cooling Air Volume [m <sup>3</sup> /h]:	> 5,550
Voltage:	400 V / 3 phase / 50 Hz
Protection Class Drive Motor:	IP 55
Drive Power [kW]:	18.5
RPM Motor [min <sup>-1</sup> ]:	2,940
Start:	Star/Delta
Noise Level [dB(A)]:	75 (±2) at distance of 1 m
Dimensions W x D x H [mm]:	995 x 1,487 x 1,800
Weight [kg]:	605
Content Volume Final Filter Housing [l]:	2.3
Content Volume Pre-Filter Housing [l]:	0.8

## SPECIAL VOLTAGE

### Technical Data



Technical Data	LW 700 ES II
Flow Rate [l/min]:	700
Max. Operating Pressure [bar]:	420
RPM [min <sup>-1</sup> ]:	1,400
Number of Pressure Stages:	4
Cylinder Bore 1st Stage [mm]:	Ø 105
Cylinder Bore 2nd Stage [mm]:	Ø 50
Cylinder Bore 3rd Stage [mm]:	Ø 25
Cylinder Bore 4th Stage [mm]:	Ø 14
Medium:	Compressed Air / Breathing Air
Intake Pressure:	atmospheric
Oil Pressure (at operating temperature) [bar]:	+2.0 (±0.1)
Oil Capacity [l]:	2.9
Intake Temperature [°C]:	0 < +45
Ambient Temperature [°C]:	+5 < +45
Cooling Air Volume [m <sup>3</sup> /h]:	> 6,660
Voltage:	460 V / 3 phase / 60 Hz
Protection Class Drive Motor:	IP 55
Drive Power [kW]:	22.2
RPM Motor [min <sup>-1</sup> ]:	3,528
Start:	Star/Delta
Noise Level [dB(A)]:	75 (±2) at distance of 1 m
Dimensions W x D x H [mm]:	995 x 1,487 x 1,800
Weight [kg]:	605
Content Volume Final Filter Housing [l]:	2.3
Content Volume Pre-Filter Housing [l]:	0.8

## SPECIAL VOLTAGE

### Technical Data



Technical Data	LW 700 ES II
Flow Rate [l/min]:	700
Max. Operating Pressure [bar]:	420
RPM [min <sup>-1</sup> ]:	1,400
Number of Pressure Stages:	4
Cylinder Bore 1st Stage [mm]:	Ø 105
Cylinder Bore 2nd Stage [mm]:	Ø 50
Cylinder Bore 3rd Stage [mm]:	Ø 25
Cylinder Bore 4th Stage [mm]:	Ø 14
Medium:	Compressed Air / Breathing Air
Intake Pressure:	atmospheric
Oil Pressure (at operating temperature) [bar]:	+2.0 (±0.1)
Oil Capacity [l]:	2.9
Intake Temperature [°C]:	0 < +45
Ambient Temperature [°C]:	+5 < +45
Cooling Air Volume [m <sup>3</sup> /h]:	> 5,550
Voltage:	230 V / 3 phase / 50 Hz
Protection Class Drive Motor:	IP 55
Drive Power [kW]:	18.5
RPM Motor [min <sup>-1</sup> ]:	2,940
Start:	Star/Delta
Noise Level [dB(A)]:	75 (±2) at distance of 1 m
Dimensions W x D x H [mm]:	995 x 1,487 x 1,800
Weight [kg]:	640
Content Volume Final Filter Housing [l]:	2.3
Content Volume Pre-Filter Housing [l]:	0.8

## SPECIAL VOLTAGE

### Technical Data



Technical Data	LW 700 ES II
Flow Rate [l/min]:	700
Max. Operating Pressure [bar]:	420
RPM [min <sup>-1</sup> ]:	1,400
Number of Pressure Stages:	4
Cylinder Bore 1st Stage [mm]:	Ø 105
Cylinder Bore 2nd Stage [mm]:	Ø 50
Cylinder Bore 3rd Stage [mm]:	Ø 25
Cylinder Bore 4th Stage [mm]:	Ø 14
Medium:	Compressed Air / Breathing Air
Intake Pressure:	atmospheric
Oil Pressure (at operating temperature) [bar]:	+2.0 (±0.1)
Oil Capacity [l]:	2.9
Intake Temperature [°C]:	0 < +45
Ambient Temperature [°C]:	+5 < +45
Cooling Air Volume [m <sup>3</sup> /h]:	> 6,660
Voltage:	265 V / 3 phase / 60 Hz
Protection Class Drive Motor:	IP 55
Drive Power [kW]:	22.2
RPM Motor [min <sup>-1</sup> ]:	3,528
Start:	Star/Delta
Noise Level [dB(A)]:	75 (±2) at distance of 1 m
Dimensions W x D x H [mm]:	995 x 1,487 x 1,800
Weight [kg]:	640
Content Volume Final Filter Housing [l]:	2.3
Content Volume Pre-Filter Housing [l]:	0.8



# AIR COOLER CONNECTION KIT

D



## AIR COOLER CONNECTION KIT

---

### Air Cooler Connection Kit

The Air Cooler Connection Kit provides an easy connection and a simple and time-saving installation or backfitting.

The piping inside the compressor is completely installed. Just disconnect the U-pipe at the outside and connect the air cooler according to the connection designation (inlet/outlet).

To operate the unit without air cooler, reinstall the U-pipe and the compressor is ready for use.

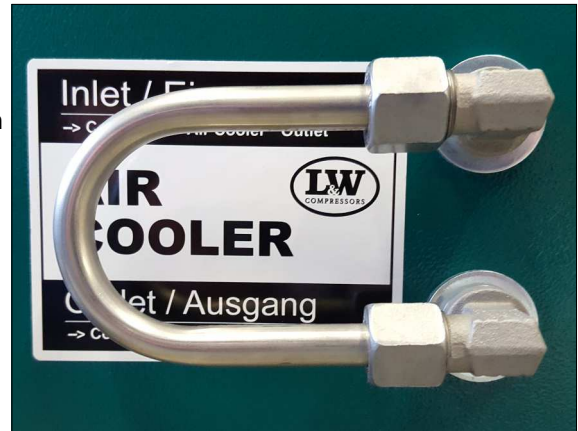

Air cooler connection kit



## AIR COOLER CONNECTION KIT

---

### Spare Part List

Best.-Nr. / Order No.	Benennung	Description
000796	Verschraubung	Elbow Connection
000902	Winkelschottverschraubung	Elbow Bulkhead Fitting
001440	Hochdruckschlauch	HP Hose
006860	Rohrbogen 180° - 10L inkl. Muttern	U-Connection 180° - 10L Pipe

D

# AIR COOLER CONNECTION KIT

## Spare Part List

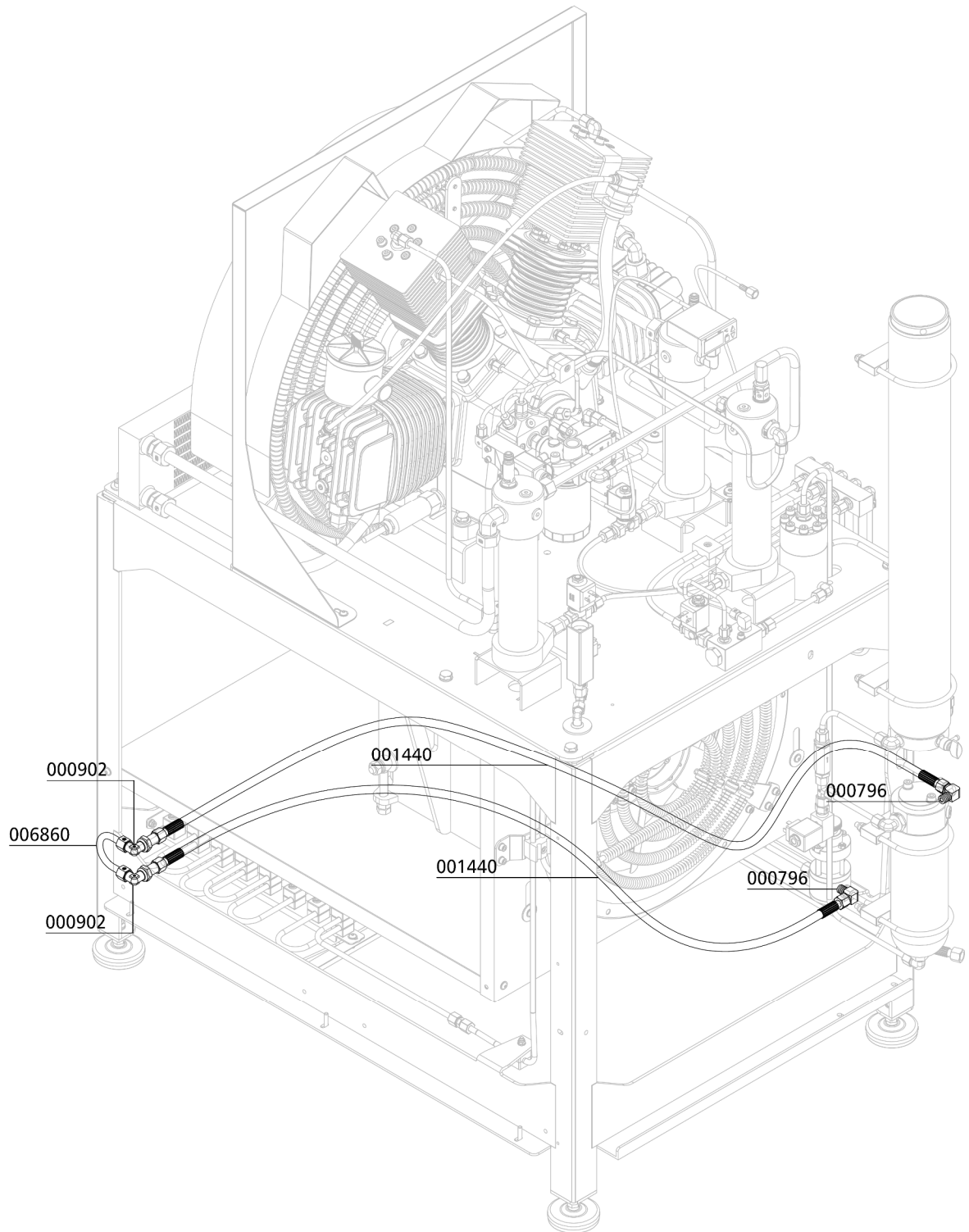

D



# ATTACHMENT

E

**Lenhardt & Wagner GmbH**

**An der Tuchbleiche 39  
D-68623 Lampertheim – Hüttenfeld**

www.lw-compressors.com



## Operating Instruction

### Safety valve

Typ:

**SiV2 BKZ 989 TÜV.SV.12-989.5.G.V.P CE 0091 AlMgSi1 F31 1100\* Lenhardt & Wagner**

**SiV BKZ TÜV.SV.14-1140.5.G.V.p CE 0091 AlMgSi1 F31 1100\* Lenhardt & Wagner**

<b>Set pressure:</b>	see mark (hand wheel on top of valve)
<b>Maximum outflow:</b>	Set pressure 100-159 bar: 750 l / min Set pressure 160-350 bar: 1.100 l / min
<b>Suitable media:</b>	Media-resistant, non-corrosive gases

The safety valve is used for protection of pressurized components, eg pipelines, pressure vessels, or the compressor itself.

The hand wheel on the top of the safety valve is marked with the adjusted set pressure.



- 1) **Identification of set pressure**
- 2) **Seal**
- 3) **Fixing screws<sup>1</sup>**
- 4) **Venting screw (hand wheel)**
- 5) **Identification serial number**
- 6) **Socket for safety valve**

Safety valve with socket

<sup>1</sup> und die Anforderungen des AD 2000 Merkblatts W7 erfüllen. The fixing screws M8 must be strength class 8.8 and meet the requirements of Merkblatt AD 2000 leaflet W7. Shaft length 70mm.

In order to prevent manipulation of the set pressure, all safety valves are factory fitted with a seal.

A safety valve on which the seal has been removed, must be returned to the manufacturer for repair / adjustment before further use.

In addition, the safety valve has a venting device (hand wheel).

When rotated clockwise, the safety valve and the filter housing of the final stage are completely vented.

During normal operation, the screw is unscrewed to the upper stop anticlockwise; an integrated safety ring prevents the screw from being removed.

---

If a safety valve blows off, the system must be switched off immediately and the cause of the error, investigated.

There are two possible reasons:

1. The safety valve is defective and blows off before the set pressure.

In this case the safety valve should be submitted immediately to the manufacturer for repair or replaced with a new one.

2. The safety valve opens properly, the problem is on the system.

A constant blowing of the safety valve is not permitted, the sealing seat of the valve can be damaged. The error on the system must be detected and repaired before further filling operations.

The safety valve may only be used if it is ensured that the maximum flowrate of the system does not exceed the blow-off rate of the safety valve.

The safety valve may only be used with the approved media.

Repair work on compressors must only be performed by trained personnel.

### **Dismantling of the safety valve**

Ensure that on the safety valve is no pressure.

Loosen and remove the two M8 fixing bolts with a 6 mm Allen key.

The safety valve can now be removed by turning and simultaneously pulling out of the socket.

### **Mounting**

1. Clean the safety valve socket.

2. Oil the insert pin of the safety valve including the O-ring with 1 to 2 drops of oil.

3. Press the safety valve pin complete into the socket.

4. Fasten the safety valve with the two 8 mm allen screws into the socket

(Tightening torque: 10 Nm)

5. Screw the venting screw (hand wheel) anticlockwise to its upper limit.

6. Start the System (Compressor), check installation for leaks and proper function.

**Manufacturer:** Lenhardt & Wagner GmbH  
An der Tuchbleiche 39  
D-68623 Lampertheim – Hüttenfeld

**Contact:** E-Mail: [service@lw-compressors.com](mailto:service@lw-compressors.com)  
Web: [www.lw-compressors.com](http://www.lw-compressors.com)  
Tel.: +49 (0) 6256 – 85880 0  
Fax: +49 (0) 6256 – 85880 14

---

**Note:**

*Only use safety valves which are in a technically perfect condition, for its intended purpose, safety and danger awareness, in compliance with the operating instructions!*

*Faults which could affect safety must be rectified immediately!*

Notes:

- The safety valve must be installed directly on the protected pressure vessel and / or the plant.
  - The safety valve must be installed in an upright position.
  - The flow area of the port must be greater than the valve opening.
  - Protect valve against splashes
- 

Maintenance:

- In accordance with current Pressure Equipment Directives, the safety valve must be periodically checked for operation and reliability.
- Refill annually lubricating oil:  
Oil filling position:  
Hole on the spacer (see arrow, Figure 1)
- Oil level: Fill oil into the hole until oil comes out of the hole.

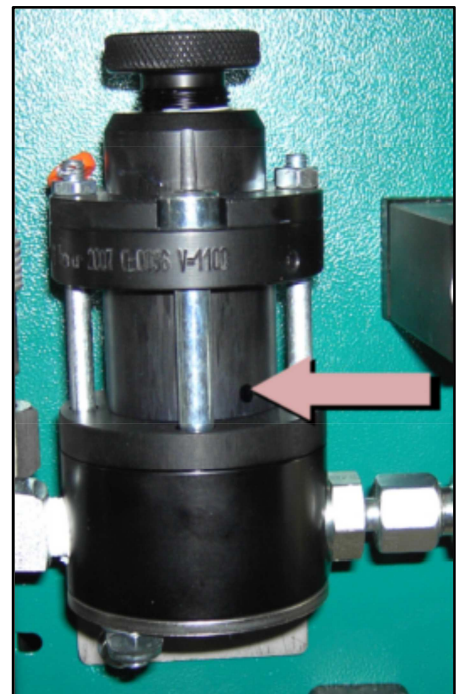

Figure 1: Position for oil refill

*To be used lubricating oil for the safety valve: L&W Article N°.: 008500 (content: 30 ml)*

---



INFORMATION ON THE  
SERVICE LIFE OF  
L&W HIGH PRESSURE HOSES







## CONTENTS

---

Testing hose lines	
Testing hose lines .....	3
Testing after assembly and before commissioning .....	3
Recurring test .....	4
Procedure for hose lines found to be "defective" .....	4
Test intervals.....	4
Persons qualified to test hose lines.....	5
 Maintenance	
Replacing hose lines .....	6
Immediate replacement of hose lines .....	6
 Service life	
Service life of L&W high pressure hoses.....	7
 Storage	
Storing hose lines .....	8
 Annex	
Scope of testing, test criteria .....	10 - 11



## TESTING HOSE LINES

---

### **Testing hose lines**

An essential factor in ensuring operational safety when handling L&W compressors is the proper testing of the hose lines used.

Tests are necessary:

- After assembly and before commissioning the hose line.
- After accidents, changes (modifications) to the compressor system, longer periods of non-use and damage due to, for example, collisions or natural phenomena (extraordinary test).
- After carrying out repair work on the compressor system that could compromise safety.
- Recurrently at fixed, regular intervals.

The proprietor must determine the type, scope and deadlines for the tests according to his or her individual operating conditions and on the basis of a risk assessment. **The specifications and recommendations of the manufacturer must be observed.** The specifications made regarding type, scope and deadlines (as well as the replacement intervals) must be documented in writing as occupational health and safety measures.

The results of the tests must also be recorded, e.g. together with the test report of the machine, and kept at least until the next test.

The above-mentioned tests may only be carried out by persons who are qualified to do so and who are authorized by the company (employer).

### **Testing after assembly and before commissioning**

In the test after assembly and before commissioning, factors relating to assembly or factors that can only be evaluated on the fully assembled machine must be assessed.

The assembled hose lines must also be assessed.

Some test points can already be assessed during a visual inspection when the machine is switched off.

An overview of the recommended scope of testing for a visual inspection of hose lines is given in the appendix.

Further test points included in the test of hose lines before commissioning, require a functional test with the machine running.

A recommendation for the scope of testing is given in the appendix.



## TESTING HOSE LINES

---

### **Recurring test**

Since hose lines are subject to influences that cause damage during operation and can lead to dangerous situations, they must be tested recurrently at fixed intervals. The aim of recurring tests is to detect and repair damage in good time.

The objective is to ensure that the system remains in a safe condition.

### **Procedure for hose lines found to be "defective"**

If defects are found during the testing of the hose line that impair the safe condition of the work equipment, these must be rectified immediately. If this is not possible, suitable measures must be taken to ensure that the machine cannot be used further before it is repaired. Defective hose lines must be replaced before the machine can be used further.

It is not permitted to repair or reassemble damaged hose lines with old, previously used parts!

If several hose lines are replaced at the same time, precautions must be taken to prevent mix-ups of the connections or the installation points.

### **Test intervals**

Deadlines for the recurring tests of the hose lines should already be set before commissioning.

Otherwise, there is a risk that work equipment will continue to be used or operated for too long without being tested.

The intervals between the recurring tests must be selected in such a way that deviations from the safe operating condition of work equipment can be detected and eliminated in good time.

The intervals for recurring tests specified here are guidelines and based on experience. Shorter test intervals may have to be specified on the basis of the risk assessment; special operating conditions; or according to the manufacturer's specific instructions in the machine operating manual. Longer test intervals may also be specified, provided that this is justifiable and tenable from a safety point of view. The determination of the test intervals should be documented.

<b>Type of test</b>	<b>Recommended test intervals</b>
Visual inspection	Before commissioning the system
Functional test	Annually with previous visual inspection

### **Persons qualified to test hose lines**

A qualified person is a person who, through his or her professional training, professional experience and recent professional activity, has the necessary specialist knowledge required for testing work equipment - in this case for testing hose lines.

These requirements are defined in the Technical Rules for Industrial Safety TRBS 1203

"Qualified persons - general requirements" fulfilled if:

- the qualified person has completed a professional training that enables his or her professional knowledge to be determined in a comprehensible manner, i.e. based on professional qualifications or comparable evidence. For the testing of hose lines, the person concerned must have completed a technical professional training or another technical qualification sufficient for the intended testing tasks. The object is to guarantee that the tests will be carried out properly.
- proof of practical use at work of the equipment to be tested as well as the associated professional experience is provided. The qualified person must be sufficiently familiar with the conditions that demand the performance of tests, such as the result of the risk assessment or observations during the working day.
- there is proof of recent professional activity in the area of the upcoming tests and appropriate further training. The qualified person must also have gained experience with regard to the tests to be performed or comparable tests. He or she must also have knowledge of the state of the art with regard to the work equipment or components to be tested as well as the hazards to be considered. This also includes knowledge of the relevant technical regulations and the updating of this knowledge, e.g. through participation in training courses/instruction.

The qualified person is not subject to any technical instruction during the course of his or her testing activity and must not be disadvantaged because of this.

Experts who have carried out tests on the hose lines up to now and who meet the three criteria mentioned above and who have familiarized themselves with the contents of the German Ordinance on Industrial Safety and Health and the changes associated with it are also considered qualified persons to whom the tests can continue to be assigned.

See also:

- ⇒ § 2 para. 7 of the German Ordinance on Industrial Safety and Health,
- ⇒ Technical Rules for Operational Safety TRBS 1203.



### **Replacing hose lines**

As a general rule, even when stored properly and subjected to permissible stress during use, all hose lines are subject to natural aging, which changes the material and composite properties and reduces the performance of the hose lines.

This limits the service life of a hose line and the operator must ensure that hose lines are replaced at appropriate intervals.

### **Immediate replacement of hose lines**

Hose lines must be replaced immediately in the event of the following defects:

- External visible damage to the hose line or fittings.
- Internal damage to the tube or the reinforcement.
- Leakage from the hose line or the fittings.
- Deformation of the hose line or the fittings.



## SERVICE LIFE

---

### **Service life of L&W high pressure hoses**

When determining the service life or the replacement interval of the individual hose lines, the concrete specifications and recommendations of the hose line or machine manufacturer must be observed. Furthermore, empirical values resulting from previous tests done under the prevailing operating conditions on site are also relevant.

Guideline values for recommended replacement intervals of hose lines which have proven themselves in practice are summarized below.

<b>Hose line requirements</b>	<b>Recommended replacement intervals</b>
Standard requirements	6 years (Service life including a maximum of 2 years storage time)
Increased requirements, e.g. due to - increased operating time, e.g. multi-shift operation, or short machine or pressure pulse cycle times - strong external and internal influences (due to the medium), which greatly reduce the service life of the hose line	2 years (service life)

The guideline given above for a replacement interval of six years for hose lines meeting normal requirements includes a maximum storage period of two years. The guideline value of two years for hose lines meeting increased requirements represents the maximum permissible service life.

A prolongation of the guideline values given above for replacement intervals is possible if

- appropriate test values and empirical values are available from the operator of the machine which permit safe continued use beyond the recommended maximum service period,
- a hazard or risk assessment, documented in writing, has been carried out by the operator, which also takes into account protective measures in the event of failure of hose lines, and
- tests for safe working conditions are carried out by qualified persons at appropriately set, if necessary reduced, intervals.

It must be ensured that the prolongation of the replacement intervals does not result in a dangerous situation that could injure employees or other persons.

If hose lines fail during operation or if damage or defects are frequently detected during the recurring tests, then, in addition to investigating the causes, the test and replacement intervals must be shortened.



## STORAGE

---

### **Storing hose lines**

When storing hose lines, storage conditions must be aimed at minimizing the natural aging that occurs over time and the associated change in material and composite properties.

For this purpose, the following information must be provided:

- Store in a cool, dry and low-dust place.  
Low-dust storage can be achieved, for example, by wrapping the hoses in plastic film.
- Avoid direct sun or UV radiation.
- Shield from nearby heat sources.
- Avoid storage temperatures below -10 °C for elastomers.
- Do not use ozone-generating light fittings or electrical devices that may produce sparks in the immediate vicinity.  
(Ozone-generating light fittings are, for example, fluorescent light sources, mercury vapor lamps).

The most favorable storage conditions are temperatures between +15 °C and +25 °C, as well as a relative humidity below 65 %.

During storage, hose lines must not come into contact with substances that could cause damage, e.g. acids, alkalis, solvents. Penetration of ozone or other harmful air constituents can be prevented by sealing the ends or by wrapping the hoses in plastic film. They must be stored flat and free of tension.

The storage period for hose lines should not exceed two years.



# ANNEX



**Recommended scope of testing "visual inspection" (before initial commissioning or recommissioning)**

- Is all user information required for safe operation of the system available (e.g. flow chart, operating instructions)?
- Do the hose lines comply with the flow chart or parts list?
- Are there protective measures in place, such as pressure relief valves, for cases of unusually high pressure pulses or pressure amplifications?
- Are the hose lines marked with the name or abbreviation of the manufacturer, maximum permissible operating pressure, nominal diameter, quarter/year of manufacture?
- Are the hose lines installed in such a way that, in accordance with DIN 20 066
  - the natural position does not hinder movement?
  - turning or twisting of the hose is prevented, likewise tensile load caused by a line that is too short and a bending radii that is too small?
  - the hose is routed via a kink protector (if necessary on the connecting element)?
  - sufficient clearance prevents external mechanical influences or abrasion on the edges?
  - hose bridges prevent damage being caused by driving over the hose line?
  - hose guides (such as hose saddles and sufficiently wide hose brackets) protect loosely laid hose lines and
  - a heat shield protects against high temperature exposure?
- Are suitable protective measures, such as fixtures, safety gear or shielding provided for hose lines that, in the event of failure, pose a risk of whipping?  
A risk is to be assumed if persons are generally present in the immediate vicinity of the hose lines, for example.
- Do the hose lines of newly commissioned or re-commissioned machines already show signs of damage?
- Are the installed hose lines still within the storage/use period recommended by the relevant manufacturer?
- Are the hose lines free of paint?
- Are the hose lines free of chafe marks?
- Does the operating manual contain information on test intervals? If so, what?

Note:

The installed hose lines should not be made from used hoses or used press fittings that have already been in use as part of a hose assembly!



## ANNEX SCOPE OF TESTING; TEST CRITERIA

---

### **Recommended scope of testing "Functional test" (before initial or recommissioning)**

Note:

Visual inspection must be carried out before the functional test

- All parts of the system must be tested at least at the maximum working pressure that could be achieved taking into account all intended applications:
  - Are the hose lines and connecting elements free of leakage?
  - Have all hose lines withstood the pressure?

Note:

The installed hose lines should not be made from used hoses or used press fittings which have already been in use as part of a hose assembly!